

See discussions, stats, and author profiles for this publication at: <https://www.researchgate.net/publication/317267760>

The Pursuit of Noninvasive Glucose 5th Edition

Book · April 2017

CITATIONS

0

READS

68

1 author:



John Smith

NIVG Consulting LLC

6 PUBLICATIONS 18 CITATIONS

SEE PROFILE

Some of the authors of this publication are also working on these related projects:



Lifelong dedication to being a noninvasive glucose "one-trick pony." [View project](#)

All content following this page was uploaded by [John Smith](#) on 31 May 2017.

The user has requested enhancement of the downloaded file.

**The Pursuit of Noninvasive Glucose: “Hunting the Deceitful
Turkey”**

By John L. Smith

Fifth Edition: Revised and Expanded

Parts Copyright 2017 by John L. Smith

Preface to the Fifth Edition^{1,2}

Two more years have passed since the last edition, and still, there is no shining light on the horizon that indicates any successful commercial device is in the offing. Many of the experiences described during the 1990-2000 era (considered by some old-timers to be the “golden age” of noninvasive glucose, and when I was employed in hopes of bringing one to the market), when there was a “froth” of interest and intrigue in the field, now seem quite dated. They are retained, even at some personal pain, because they serve as echoes of events that may come again.

New jousts at established areas, without success, have been reported, including examination of breath, saliva, tears, sweat, and this time, even urine. Ideas such as microwave spectroscopy, light scattering, and radio-frequency impedance have been re-investigated, and just a few truly new approaches have been described.

Emphasis on the new, serious players in the field (Apple, Google, Samsung, and Microsoft) has continued, but see the section inside regarding Google’s touted contact lens. See also the section on Integrated Diabetes Management and “recent trends” to see how the field is evolving.

The fact that success has eluded all the previous attempts does not seem to have slowed new investigations into the field. Although it is unlikely that they will be followed, the paragraphs below may be of help those who choose to tilt at this windmill.

In my experience, the following disciplines are required for a reasonable chance at success:

¹ A note about Internet links. At the risk of reading like a [Wikipedia](#) entry, the first appearance of companies, groups, and systems that were current or have persistent links as of this writing in 2017 will be provided with links that mostly survive into the .pdf edition you are reading. Many of these groups are ephemeral, and some don’t survive beyond a single initial press release, so please accept the reality that quite a few of these will be dead ends. Any that had already disappeared by the time of writing have been deleted.

² Sadly, David Mendosa, who hosted this book on his site for more than ten years, and who passed along many requests for help with noninvasive glucose investigations, is no longer with us. He will be sorely missed by the entire diabetes community.

- In-depth knowledge of all the disciplines related to your primary technology, e.g., optics, electronics, software, mechanical engineering, etc.
- Biochemistry, especially knowledge of the glucose molecule and its relation to the chosen field of technology.
- Physiology, especially the distribution of glucose in fluids and tissue.
- Metabolism, especially glucose sources and sinks.
- Diabetes, especially aspects of the disease that will affect your technology.
- The history of noninvasive investigations, especially in your technology field—what didn't work and why.
- The regulatory requirements for a diagnostic device, and the structure of the market for existing devices.

In addition, here are a few guidelines regarding what else it takes for an attempt. Because each new investigation starts with just an idea, progresses to simple testing on friends and family, then constructs a working prototype to test critically, each attempt eventually needs more resources than the average experimenter can supply, this is what experience of many groups indicate a new attempt might require:

Phase	Approximate Cost	Approximate Time
Try the idea out on a few people with very crude instrumentation	A few hundred thousand dollars	1-2 years
Develop and test a prototype (this varies widely, depending on the complexity of the technique)	1-5 million dollars	1-3 years
Conduct a disciplined clinical test, approach a regulatory body to get their response	3-5 million dollars	1-3 years
Conduct pivotal clinical trials suitable for a regulatory submission	10-20 million dollars	1-3 years

Gain regulatory clearance	10-20 million dollars	2 years ¹
---------------------------	-----------------------	----------------------

The most optimistic addition of these times and amounts means you will need to spend a minimum of five years and raise 25-30 million dollars to be ready to place a device on the market. Presuming that the technology is not sold to one of the established entities in this field (a prospect that grows more unlikely with each passing year of a contracting marketplace and declining profitability), no matter how rapidly the market would embrace a new noninvasive device, time and money that must be allocated for manufacturing scale-up, establishing a distribution network, and educating both patients, providers, and insurers about the new system, will require additional resources and funding. Business plans that ignore these realities may look attractive, but will not withstand the scrutiny of experienced investors.

If I Google “noninvasive glucose” (and ignore the advertising entries), the first ten pages will contain 100 responses. These results are statistically meaningless, because I spend a great deal of time on my computer searching for everything published on the subject, and of course, Google knows *everything* about each of us. Also, tomorrow’s results will be different:

- Articles of greater or lesser scientific accuracy about a single product or technology: 30
- Websites for companies or inventors: 22 (3 sets of duplicates)
- Online magazine stories about one or two technologies: 20
- Serious review articles about the field: 8
- News reports of actual events: 7
- Market research reports (\$2,850-\$3,235): 6 (1 in triplicate, one patent landscape report that might actually be worth the price)
- Wikipedia entry: 1
- Indiegogo sites: 1

¹ As described below, the requirement established by the FDA is that noninvasive technologies must all be submitted for “pre-market approvals.” While it is possible to obtain clearance for a PMA approval in 270 days, the average length of time is 18 months.

- Actual clinical trials: 1
- Unsafe sites: 1
- Self-published thesis: 1
- Quora site asking “Why isn't there a non invasive blood glucose test yet?”: 1
- This book: 1

The section below was part of the preface to the Fourth Edition; it is included again because of the importance of the illustrations. A popular illustration of the sequence of events in emerging technologies is known as “[Gartner’s Hype Cycle](#).”

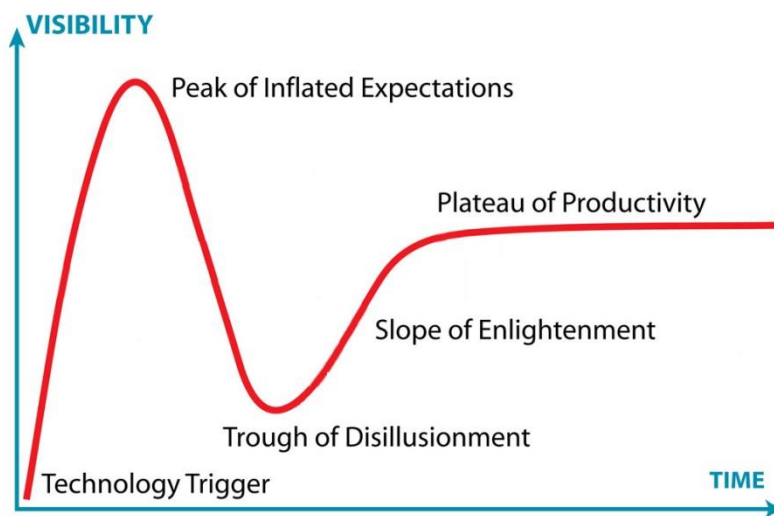

There are many who feel that the correct version for noninvasive glucose measurements should be:

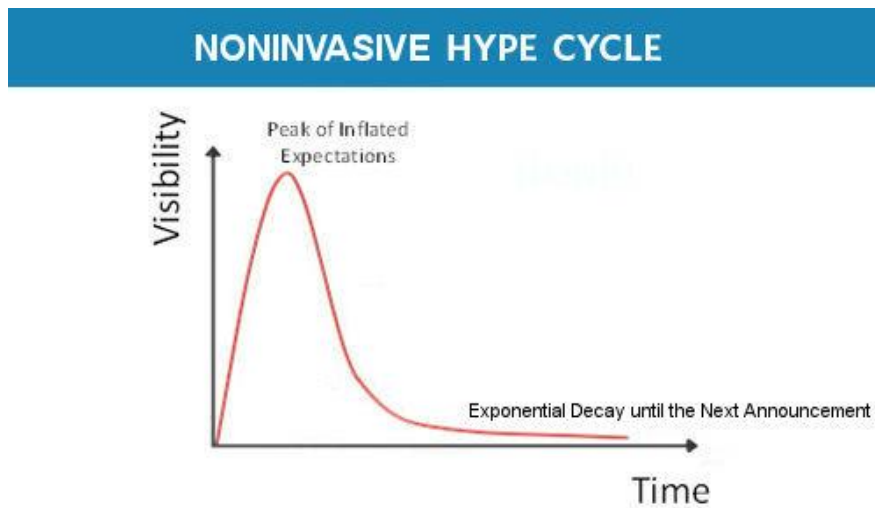

A version was even created by [Stephen Davies](#) in 2014 for *Digital Health*:

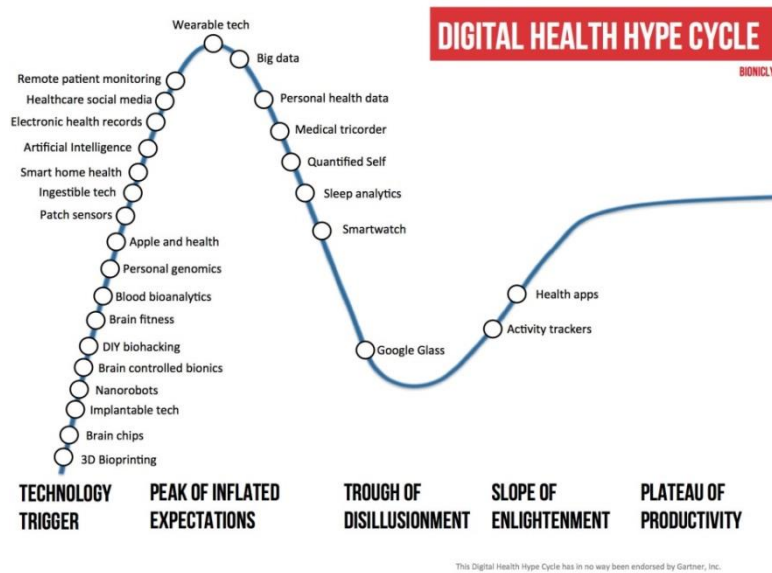

Source: <http://bionicy.com/digital-health-hype-cycle/>

Anyone can view, copy, and reproduce any part of this work for non-commercial purposes as described in the [fair use](#) clause of United States Copyright Law. Reproduction of any copyrighted part of this work in any form for commercial purposes is strictly forbidden.¹

¹ [Glenn Elert](#), who will probably be writing the wonderfully instructive and readable [Physics Hypertextbook](#) as long as he is alive, taught me to add this statement. He also suggests including the Latin phrase *Opus in profectus*: “work in progress.”

Foreword

This is a compilation of experiences and investigations, now stretched over 35 years and born of a combination of scientific curiosity, dedication to people affected by a chronic, life-threatening disease, and dogged determination to find a solution to the most difficult technical challenge I have encountered in my career. It is not, perhaps, as difficult or fraught with problems as realizing time travel or finding the final “grand unifying theory” of physics¹, but it is the more tantalizing because it seemed for decades that the solution was always “just around the corner,” or at most, “just over the horizon.”

I participated in development and evaluation of many of the technologies (even a few of the new ones) described here while employed at several companies directly or peripherally involved in glucose measurement, and have consulted for the inventors or investors of many others. In the text, I will describe many of the technologies, their capabilities and (especially) their limitations for measuring glucose. I will articulate three very important “Laws of Noninvasive² Glucose” (one with several subsections), and list tests which can be applied to spectroscopic and other techniques. Much of the description is technical, since it is the subtleties of the approaches that often lead to their failure. Nontechnical readers should still try to read through these—the conclusions are valid, some of the reasoning may be helpful, and there is certainly value in them as cautionary tales. Where companies have made a splash, or serve to illustrate the behaviors that were exhibited by many of those in this field, they will be described in some detail. In other cases, simple lists of the investigators will serve to illustrate how many times a similar approach has been attempted.

Although I do not (yet) have diabetes, it has achieved epidemic proportions in this country, and is, as the standard of living rises elsewhere, increasingly felt more equally around the world. After spending many years devising instruments that measure blood

¹ This is the long-sought system for reconciling General Relativity and quantum mechanics that caused Einstein so much heartache in his later years.

² Although I will follow the punctuation rule that short prefixes such as “un-” and “non-” are generally unhyphenated unless confusing, the term appears equally often as “non-invasive,” and this can complicate searches, depending on the sophistication of the search process used. When searching patents, for instance, both forms must be included.

glucose and participating in the explosive growth of the home blood-glucose monitoring industry, the need for a device that would allow people to measure their glucose without pain or trauma is as clear to me as it is to people who would use it. As will be described here, it is not through lack of effort, creativity, entrepreneurialism, or funding that no solution has yet been found. Nor is it due to a deficiency of craftiness, manipulation or chicanery. The immense market size (still estimated worldwide at perhaps ten billion dollars in 2017), together with the pent-up demand by millions of patients, will create an immediate financial success for the organization that finally solves this problem. A device of acceptable accuracy, of reasonable size, and at reasonable cost, would still be an instant medical and commercial success. For all these reasons, hope springs eternal in the hearts of scientists, entrepreneurs, opportunists and charlatans alike.

One of the most disturbing aspects of this field has been perennial announcements by fledgling companies that the problem has been solved, and that people with diabetes will no longer have to stick their fingers.¹ These have been premature and, almost without exception were meant to generate “hype” in order to increase awareness of a company that is trying to raise money, but equally frequently, they raise false hopes in people who need the product. News media have never been able to resist reporting these “end-of-finger stick-testing” stories, and they have a fresh audience each year, as hundreds of thousands of people are newly diagnosed with diabetes. Each new group gradually tires of the premature announcements and develops a level of cynicism. As I will detail, no successful device has yet been developed, and any real prospects for one remain in the future. Another cause for concern in this field is that, in all too many cases, the same technology has been picked up and investigated after others have determined that it will not succeed. Because there has been no previous accounting of these multiply-investigated approaches, investigators and investors alike have no guideposts to direct them.

This book will be of interest primarily to those who have participated in this enduring quest, those who seek to invest in the field, or perhaps to those who have heard too many

¹ It brings to mind the number of articles in popular science magazines about the soon-to-be affordable car that converts into an airplane to fly swiftly over traffic jams.

false promises about the “coming noninvasive revolution.” Many of the illustrations, (and no small amount of the information presented here) have been “borrowed” from the experiences and websites of others who have preceded me in this field, most notably David Mendosa, who maintained for many years an accurate list of participants in the noninvasive glucose field while chronicling the history of glucose monitoring.

This book is not intended as an “exposé” or as a “tell-all;” the personal experiences detailed here are provided for the purpose of providing deeper insight into the thoughts and processes of those who have engaged in this corner of scientific exploration and as guidance for those who may follow. It is also not intended to be an encyclopedic accounting of every group or every technique explored—some never crossed my path, while others are simply repetitions of those detailed here. The breadth of those described, however, should indicate the extreme range of investigations in this field.

I am indebted to my wife, Susan, for her expert editing and for enduring my tormented existence over the entirety of this pursuit, and to my reviewers: Keichi Aoyagi, [David Mendosa](#) and [Sam Perone](#). The content is as accurate as memory and retrospective research will allow. There is undeniably bias, and the strong emotions arising from many failed attempts (mine and others’) cannot be denied. Where there are errors, they are exclusively mine. Some of the stories may bring a degree of chagrin or embarrassment to those involved; the details are included only to provide full flavor for what transpired. If anyone described here feels he has been wronged, misrepresented, or insulted, I apologize, but I do not recant.

[Author’s note: “Hunting the Deceitful Turkey” is a short story by Mark Twain (Samuel Clemens) that describes his boyhood experience of pursuing a turkey who allows him to repeatedly approach her, only to rush off as he comes near. It is appended to the main text.]

Table of Contents

Preface to the Fifth Edition	iii
Foreword	viii
Introduction and Background	2
A Brief History of Blood Glucose Monitoring	3
“IDM”	15
Why is Noninvasive Such a Big Deal?	17
Noninvasive Glucose: Background and Definitions	20
Resources	26
Know the Enemy	31
A Few Notes about Regulations	34
Patents	38
It Ain’t Necessarily So	40
Measurement Techniques	42
Spectroscopic Techniques	42
Near-infrared	44
The Reference Problem	51
Mid-Infrared	53
Mid-Infrared Emission	55
Stimulated Emission/Stimulated Raman	56
Terahertz Spectroscopy	58
Photoacoustic Spectroscopy	59
Optical Rotation	61
Optical Rotation in Tissue	65
Light Scattering	66
Transdermal Techniques (and other trans-membrane techniques)	67
The Retina	73
Saliva	81
Breath	83
Hypoglycemia Monitors	87
Tying Ideas to New Technologies	89
Why Does It Keep Going On?	93
What Makes Everyone Think Their Approach Works?	95
Oral Glucose Tolerance Tests	96
Correlation	98
Clarke Error Grid	101
Emotional Considerations	107
Tests of Technologies	111
Rigorous Evaluation of Results	113
Individual Regression	114
More about Calibration	115
Individual vs. Universal Calibration	118
Clinical Studies	119
Why Don’t People Communicate the Results of their Work?	121
Technologies and Groups	123

Near-Infrared: The 800-Pound Gorilla	123
Other Approaches	154
Transdermal Measurements	154
Pulse Oximetry Related Measurements	157
Pulse Wave	158
Nuclear Magnetic Resonance (or MRI)	161
Microwave Spectroscopy	161
Subdermal	162
Radio Frequency/Impedance	164
Microporation	170
Optical Coherence Tomography	172
Thermal and “Combination” Techniques	175
Evanescent Wave Spectroscopy	180
Retinal Pigment Regeneration	183
Fringe Players	184
Summary	187
Afterword	189
Appendix A	190
Index	192
About the Author	203

Introduction and Background¹

John Whitehead, grandson of the founder of what was then the world's largest clinical laboratory instrument company ([Technicon Instruments](#)), was visibly excited. The year was 1982, and the picture he was holding was a wristwatch, displaying “Blood Glucose = 107.” “Wouldn't that be great!” he bubbled, “No more trips for diabetics to the doctor to measure blood sugar, no more need to stick a needle in your finger to make measurements at home.” The only problem then, and for at least the next 35 years, was that it didn't work.

To understand the background and driving force for this elusive technology, it is necessary to understand the nature and impact of the disease that created it. Diabetes is a condition in which the body's natural control of blood sugar (glucose) has been lost. Whether it's termed type 1 (previously known as “juvenile-onset”), type 2 (“adult-onset”), or the gestational diabetes that is a complication of pregnancy, the end result is the same—glucose may be present in the blood in dangerously low (“hypoglycemia”) or high (“hyperglycemia”) amounts, and without a means of measuring glucose, treatment is a dangerous guessing game of taking pills, injecting insulin, or deciding how much and what kind of food to eat.

Since diabetes touches almost every family at some time, most people are familiar with the long-term complications of the disease: eye damage, kidney damage, loss of feeling in the extremities, slow healing of wounds and frequently, amputations of toes, feet or legs; and often most seriously, cardiovascular disease. If patients adhere strictly to a proper diet, exercise, medication and make frequent measurements of blood glucose to adjust medication dosages and make themselves aware of the results of these efforts, they

¹ About the page numbers: This monograph has now been edited on the following versions of Microsoft Word: 2003, 2007, 2010, and 2013. As anyone with experience about multiple revisions of this application knows, some of the features that were incorporated in earlier versions become problematic later on. Every attempt has been made to make the table of contents and index page numbers accurate, but some oddities, such as “ii” for this page number, remain.

are able to maintain their health, and indeed, lead relatively normal lives. If simple, inexpensive, reliable and painless tests were available, they could make those measurements as well and as often as required.

A Brief History of Blood Glucose Monitoring

The disease has been known since ancient times, and because high levels of blood glucose will also cause the kidneys to deposit glucose into the urine, it's said that the Chinese used to test for the disease long ago by seeing if ants were attracted to sugar in a patient's urine. Testing urine for glucose as a diagnosis for diabetes has been done for over a century (before modern chemical techniques, *tasting* a urine sample was even considered a valid test), but allowing patients to test their urine as a means of monitoring blood glucose is more recent. In 1941, the Ames Division of Miles Laboratories (the division name reportedly came from that of the president, a physician named Walter Ames Compton), in Elkhart, Indiana, introduced a tablet based on a standard test for certain sugars involving copper sulfate, called Benedict's solution. One of these "Clinitest" tablets could be added to a few drops of urine, and the resulting color, from bright blue to orange, compared to a series of printed colors on the instruction sheet and the approximate level of glucose in the urine estimated.¹



Urine testing for glucose, however, has very serious problems. When a person first develops diabetes, the level of glucose in urine is a reasonable indication of excessive amounts in the blood; however, because both normal and low blood glucose levels result

¹ These tablets are still sold in the U.S., but may be more commonly used today by winemakers to measure the amount of "residual sugar" in a fermented wine.

in no glucose in urine, it is never possible to assess those blood levels using urine tests. As the disease progresses over time, it becomes much less reliable as a marker of high blood glucose. Even early on, it's never an accurate measure, and even though improved testing devices ("dipsticks") have been developed over the years, it's never been more than a "semi-quantitative" test. To get accurate values, it's necessary to measure the amount of glucose in the blood itself, and this has long been done in doctors' offices and laboratories. However, for people with diabetes to maintain healthy levels of glucose, there has always been a need for simple, accurate tests they could perform at home.

In 1964, after developing many dipstick tests for urine, Ernest Adams of Ames developed a practical test strip for measuring glucose in blood named Dextrostix, after dextrose, another name for glucose. Instead of using a chemical reaction to measure glucose, as Clinitest had done, Dextrostix used a biochemical reaction with an enzyme called glucose oxidase, which reacted with glucose to produce hydrogen peroxide. The hydrogen peroxide produced a color from another chemical called o-tolidine, and the amount of color on the strip after exposing it to a drop of blood was a good measure of the amount of glucose present. At first, the amount of color was simply compared to a series of printed colors on the package label, and the glucose concentration was estimated by color comparison. The procedure was not trivial but could be mastered by people with reasonable dexterity for home use:

- Freely apply a large drop of capillary or venous blood sufficient to cover entire reagent area on printed side of strip.
- Wait **exactly 60 seconds**. (Use sweep second hand or stopwatch for timing.)
- Quickly wash off blood (in 1 or 2 seconds) with a sharp stream of water, using a wash bottle and blot **once** gently on a lint-free paper towel.
- Read result within **1 or 2 seconds** after washing. Hold the strip close to the Color Chart. Interpolate if necessary.



The major limitation to this approach, aside from the blood volume, the timing and manipulation involved, is that visual acuity and the ability to perceive color accurately decrease with age. And since people with diabetes are especially prone to cataracts (darkening and solidification of the lens in the eye), those who most needed to perform the test were least able to perform it without assistance. As it turned out, Dextrostix were good enough that better accuracy could be obtained by making an electronic measurement of the amount of color on the strip, and at least three meters were developed to do so. The first, developed at Ames by Anton Clemens, was called the Ames Reflectance Meter, or A.R.M. According to interviews with Clements, he was ordered to drop the project several times but somehow managed to bring it to the market, and the first electronic blood glucose device could be purchased in about 1970 for about \$400. Unfortunately, it had some reliability problems, mostly from its rechargeable lead-acid batteries, and its use didn't become widespread. Close examination of the scale on the meter below indicates that it only read very high glucose values, but it appears that the knob on the right could select among scales with different ranges, as in the lower picture.

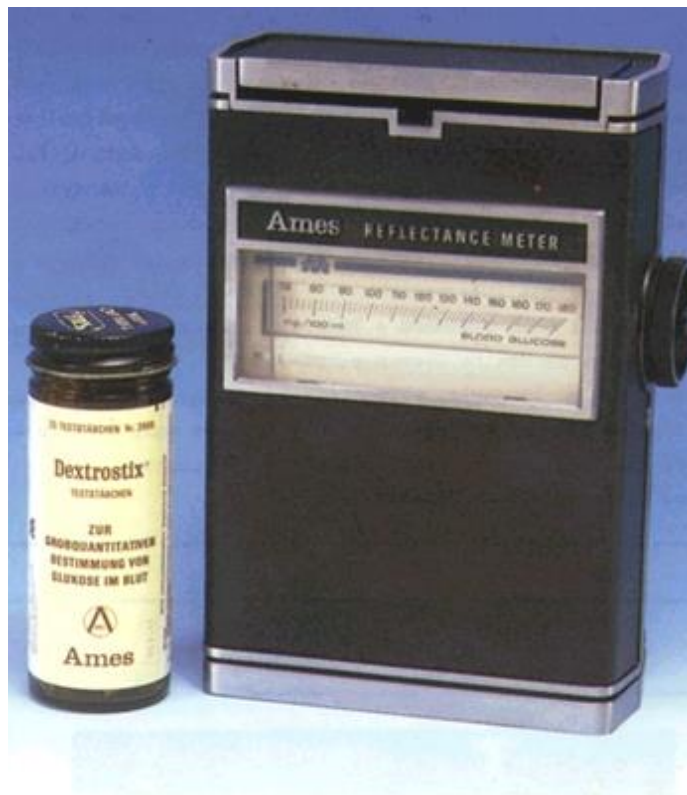

The next electronic strip reader to appear was in about 1972, called the Eyetone, and was manufactured by a Japanese company, Kyoto Dai-ichi (which later changed the company name to [Arkray](#)). It also read Dextrostix, but used a plug-in AC adapter for power instead of batteries.



In about 1979, Kyoto Dai-ichi introduced an improved Dextrostix meter with a digital readout, called the Dextrometer.



Boehringer Mannheim, which had developed a parallel blood glucose test strip for visual color comparison called the Chemstrip bG, kept pace by introducing a meter to read the strips, the Accu-Chek bG in about 1982. An early version (that may have read an earlier version of the strip) was developed by the BioDynamics Company in Indianapolis and introduced as the StatTek in 1974, and the company was quickly purchased by

Boehringer. The Chemstrip bG was preferred by many over Dextrostix because the blood could be wiped off the strip (with a cotton ball) after a minute's contact instead of washing off with water. Later versions of the meters were called Accu-Chek in the U.S. and "Reflolux" overseas.

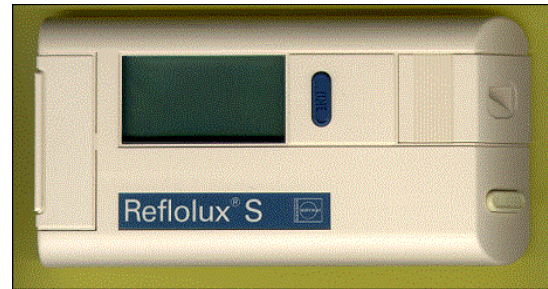

-/-

West J Med. 1982 March; 136(3): 275.

Stat-Tek Glucose Analyzer for Diabetes

QUESTION:

Is intermittent self-monitoring of blood glucose using the Stat-Tek glucose analyzer an acceptable practice for diabetes?

OPINION:

It is the opinion of the Advisory Panels on General and Family Practice, Internal Medicine, Pathology and Pediatrics that home self-monitoring of blood glucose by diabetics can be an effective and acceptable means of stabilizing control of some patients having insulin-dependent diabetes, including pregnant diabetics and others for whom strict control should be achieved. Among the factors to be considered are (1) the motivation and reliability of the patient, (2) the need for periodic quality control checks and (3) cost of various home monitoring systems.

THE WESTERN JOURNAL OF MEDICINE 275

LifeScan¹ entered the market in about 1981, with a meter (first called Glucocheck, then GlucoScan) developed in England by Medistron and with test strips developed in Japan by the Eiken corporation—the first product in which the meter wasn't preceded by a strip intended for visual comparison². That product was also intended to have blood washed off the strip, but on the night before introduction of the product at a national diabetes meeting, it was discovered on testing the first strips delivered by the reagent manufacturer that the blue dye formed from glucose also washed off the strip with the blood! Ray Underwood, the founding vice president of engineering, experimented with blotting paper he found in his hotel room and found that acceptable results could be obtained if the strip was blotted with *just the right* amount of pressure.

¹ LifeScan's original company name was Diabetech—that name resurfaced with a company in Dallas, TX, making wireless monitors and diabetes management systems.

² Interestingly, LifeScan's original business plan was to produce test strips for use in meters offered by other companies. The irony of this became evident when two companies began to sell strips in 1993 that worked in LifeScan's One Touch meters. Since the strips infringed LifeScan's patents, extended patent infringement litigation, in which I was intimately involved, resulted in their effective removal from the market, but not before one of the companies sold over \$100 million worth of test strips in just a year. Ironically, this was repeated twenty years later in 2012-2014, when two different companies brought out test strips that worked in LifeScan's One Touch Ultra electrochemical systems. I was called back into service to assist with patent infringement litigation against both companies.



Some of the early GlucoScan meters had their own reliability problems, but they sustained the company until it was purchased by Johnson & Johnson in 1986 and introduced radically new technology in 1987 with the One Touch meter and strip.¹ The meter shown below at the left is the original One Touch meter, with the One Touch II, then the One Touch Basic (No photographs of the original One Touch meter have been located, but see the source of this picture below in the chapter on near-infrared spectroscopy).

¹ One of the reasons the One Touch was so successful, in addition to its freedom from user technique variations, was that it was the first meter to provide truly accurate measurements in the critical low end of glucose concentrations, where patients are in acute danger from hypoglycemia. While a glucose value of 70 mg/dl is considered normal, 60 mg/dl can mean that the patient is hypoglycemic and nearing dangerously low levels. Most of the earlier measuring systems (and many of the later ones) provided poorer accuracy in this critical region, while the One Touch, where the meter examined every test strip before blood was applied to it, gave accurate results even at very low levels.

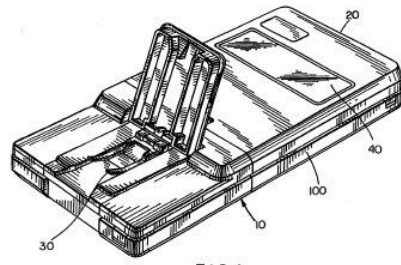

The One Touch was the first of what LifeScan termed “second generation” blood glucose meters, in that no timing, wiping, blotting or washing of the blood was required. A strip was inserted into the meter, a drop of blood was placed on the strip with “one touch,” and the result was displayed in 45 seconds. A second meter in this category was unique in that it used an “electrochemical” measurement (a reaction with glucose in blood that generated an electrical current related to the glucose concentration) instead of the “photometric” (color measurement) approach of all the earlier ones. It was called the Exactech, with a strip developed in England, manufactured by MediSense and marketed originally in the U.S. by Baxter, and came in the form of a either a slim pen or a credit-card sized, thin plastic package. Early versions of the device had both accuracy and reliability problems, which hampered its early market acceptance.



Major suppliers of insulin have also shown interest over the years in both glucose monitoring and noninvasive measurements. Eli Lilly¹ introduced a meter in about 1988, called the Direct 30-30. It used an electrochemical system with a membrane that supposedly lasted for 30 days and completed a test in 30 seconds. It was withdrawn from the market a year or two later².

Novo Nordisk, another large insulin company, acquired a number of technologies during the 1990s to provide a system for measuring glucose, including an electrochemical meter with a renewable surface, where a fresh layer of electrode was exposed after each test by “shaving” off the old surface with a built-in blade³.

Meters and strips have continued to evolve, with test times being reduced to only a few seconds, and blood samples as small as 0.3 microliters (Dextrostix used a drop of about 50 microliters, so the reduction in blood drop size has been about a factor of 150). As it has been for the past thirty-five years, the market today is dominated by no more than four players. Today, all but one are still subsidiaries of giant pharmaceutical companies: LifeScan (J&J), Roche (who bought Boehringer Mannheim in 1998), Bayer (who acquired Miles in 1979, but only changed the name in 1995), and Abbott, who bought the MediSense (Exactech) brand in 1996 for \$876 million and TheraSense in 2004 for \$1.2 billion.

Although the market contraction described above has deeply impacted all of these companies, Bayer was to first to formally exit by selling its glucose testing business to a division of Panasonic and change its name to Ascensia, who had manufactured meters and test strips Bayer sold for decades. Roche, long rumored to be also spinning out, could also consider selling except for the absence of willing buyers. LifeScan had maintained a shrinking business, and even rebranded its Animas insulin pump (which links to the

¹ Futrex, developer of the “Dream Beam,” had a relationship with Lilly that only became public when a patent issued to the founder, Bob Rosenthal, carried an assignment to Eli Lilly.

² There were two conflicting versions of its market withdrawal. Lilly said that it was not sufficiently resistant to electrostatic discharges, while the original inventors claimed that the membrane was much too robust, lasted too long, and provided a minimal income trail for Lilly.

³ One of my last activities at LifeScan before retirement was to travel to Denmark to look at the technologies Novo Nordisk had acquired and was now preparing to abandon to focus on its core insulin business. LifeScan chose not to pursue them.

Dexcom CGM systems) as “One Touch,” a name that became well known with the company’s ascendancy in the business. In late January, 2017 however, J&J made this somber announcement:

“Additionally, as part of the Company’s ongoing portfolio management, the Company is announcing it is engaging in a process to evaluate potential strategic options for the Johnson & Johnson Diabetes Care Companies, specifically LifeScan, Inc., Animas Corporation, and Calibra Medical, Inc. [the insulin “patch pen” company it had acquired in 2012] Strategic options may include the formation of operating partnerships, joint ventures or strategic alliances, a sale of the businesses, or other alternatives either separately or together. All options will be evaluated to determine the best opportunity to drive future growth and maximize shareholder value. There can be no assurance that this process will result in any transaction or other strategic alternative of any kind.”

All the leading systems today are based on electrochemistry, with subtle differences in technology of interest primarily to electrochemists. Meters and strips are still reimbursed at reduced rates by Medicare and virtually all insurers, and the “category,” as it’s called in the wholesale and retail drugstore business, has entirely replaced the original “razor/razorblades” paradigm with its meters, which are given away or sold at a loss, and the consumable strips, which still generate the reduced profits. Consumers had long suspected that the test strips were extremely profitable, but it was only unintentionally acknowledged when J&J initiated a policy of placing its companies’ products in the “company stores” (where employees could buy baby shampoo and “Band-aid® Brand Adhesive Bandages,” as the company insisted the product be referred to in print) at the product’s “standard cost,” the amount it cost to manufacture the product. One Touch strips appeared in these stores nationwide (J&J has over 170 companies) for about five cents each, and the awareness of consumers of the level of profit involved was viewed with grave concern by LifeScan. Since the strips retailed at that time for sixty-five to seventy cents, a number of J&J employees were tempted into becoming minor entrepreneurs by re-selling test strips, until the policy was modified and a company store price closer to the wholesale price was established.

Recent Trends (as of 2017)

After at least two decades of studies urging people with type 2 diabetes to test their glucose regularly to prevent complications, the practice has been de-emphasized recently to a substantial extent. The combination of cost containment, where lower levels of reimbursement are provided for diabetic supplies, together with the development of drugs which more effectively manage glucose levels¹, has contributed to a reduction in testing across the type 2 population. In addition, chain drug stores have begun to promote “private-labeled” blood glucose monitors made for them which carry the “CVS” or “Wal-Mart” Reli-On brands at lower prices, further lowering sales and margins for the established suppliers. While glucose monitors and strips were once a very profitable business (LifeScan’s profit margin among Johnson & Johnson companies was exceeded only by the purely pharmaceutical operations in the glory days of the 1990s), the market contraction since about 2005 has resulted in less research, reduced sales forces, and has created more intense price competition among the established companies. While it is possible that this trend will also reduce the emphasis on a noninvasive monitoring solution, there is no indication of a slowdown among inventors trying to provide novel approaches to solve the problem, even if the big players appear to be less receptive to ideas presented by these inventors.

At one time, strips which cost no more than a few cents to manufacture sold for as much as \$1.00 each, but in 2013, the Medicare reimbursement was reduced to 21 cents/strip, and strip purchases under Medicare were subject to [competitive bidding](#), which together effectively placed a cap on strip prices. In 2016, the rate was further decreased to just under 17 cents per strip. It is likely that the decreased profitability of these companies to make it even harder for new ideas to gain support and funding there, and to reduce the likelihood that a big company would be willing to acquire a promising startup company, at least until such a technology is viewed as a threat to ongoing business or an irresistible opportunity for market share expansion—either situation would require a much more well-developed technology than has appeared to date.

¹ These include “glucagon-like peptide,” or GLP-1 agonists like [Byetta](#) and [Bydureon](#) from AstraZeneca, [Trulicity](#) from Lilly, and [Victoza](#) from Novo Nordisk; “dipeptidylpeptidase inhibitors” or DPP-4 drugs like [Januvia](#); as well as the more recent sodium-glucose transporter” or [SGLT2](#) inhibitor drugs from several suppliers.

“IDM”

As “big data” (the computerized analysis of data aggregated from many sources) has advanced, an even more fundamental change has appeared, which generally goes by the term “[integrated diabetes management](#),” or IDM (sometimes also called “interconnected diabetes management”). While much of health care has been historically focused on treatment of diseases, and has gradually moved to prevention of, especially, chronic ones, effort is now shifting to “outcomes,” where the patient’s long-term health is paramount, and health care begins to integrate approaches which reduce cost both now and from future complications.

Much of this effort is driven by increasingly large health-care insurance companies, who strive to stay profitable in the face of ever-rising costs, but also by the increasing involvement of government agencies, particularly Medicare, deciding what they will reimburse, and by how much. As the incidence of type 2 diabetes continues to rise, efforts have been initiated by government, health insurance companies, and even employers, to maintain a population with the best outcomes, and of course, least expensive health care. If type 2 diabetes is to be managed, it has become increasingly apparent that once-daily glucose tests are of limited value. Yes, they give some guidance about how yesterday’s food was metabolized and how high glucose levels are after a night’s rest, but the value of them for altering behavior or adjusting medication types and dosages is minimal. Like every big data pursuit, what is needed is more information, and the way that is obtained is through continuous glucose monitoring (CGM).

[Dexcom](#), which is the current leader in subcutaneous CGM systems, made headlines in 2016 by being the first company whose glucose results are allowed by the FDA to be used set insulin dosages (the first “replacement” labeling, where CGM data can legally be used instead of finger stick results). In the same year, Abbott’s long-delayed CGM system, The FreeStyle Flash (also known as the FreeStyle Libre Pro) also received [FDA approval](#) for professional use, although not yet the same replacement labeling, but it is the only CGM advertised as “factory calibrated” so it doesn’t require daily finger-stick calibration by the user.

Even though the other CGM sensors (Dexcom and [Medtronic](#)) must still be calibrated by daily finger stick testing, they provide a great deal of information for people with type 1 diabetes, where the need for testing is much more frequent as well as more urgent. At present, CGM is only reimbursed for people with type 1 diabetes, but with the increasing emphasis on “more results, more often,” the extension of this technology to type 2 diabetes is almost inevitable. Dexcom has made much of their cooperative relationship with Google Life Sciences (renamed “[Verily Life Sciences](#)”), and several patent applications (e.g., US20160235346, US20160235365) for that company’s “[bandage](#)” glucose sensor appeared in 2016. If this approach can meet its ambitious cost-reduction goals, it will combine with the IDM trends to demand inclusion of reimbursement for people with type 2 diabetes.

Adding up all these trends: less daily finger stick testing, lower test-strip reimbursement, CGM, and IDM, it is clear that the future of the traditional “strip-and-meter” glucose monitoring business is not bright. But there is a further, important implication for the noninvasive monitors described here—any which are intended for occasional, “episodic” use will become increasingly less favorably viewed, and it is reasonable to gamble a prediction that only continuous, “wearable” noninvasive monitors will have a real chance of being successful in the extended future.

Why is Noninvasive Such a Big Deal?

Everyone has had an experience, most of them unpleasant, involving sharp objects and blood.¹ Before home blood glucose testing became common, the only lancing device available was a sharp piece of stamped steel that made a painful and fairly deep cut in the fingertip.



In parallel with the development of blood glucose meters, lancing devices also evolved. Both small, disposable units and reusable “pens” with replaceable tips became commercially available, and these had the added advantage that the sharp point was hidden from view. They were also spring-loaded, so pushing a button replaced one’s own “stabbing” motion that was previously required to pierce the skin.² Another attempted

¹ I have never been a fan of needles, and the first day I went to work in 1962 at what was then the Pitman-Moore Division of Dow Chemical Company (which made human and veterinary pharmaceuticals), the company nurse dug around in my arm looking for a vein until I passed out. For a long time after that, I was reluctant to have blood drawn or have an injection for anything, so I was less than enthusiastic when Pitman Moore began to eye the burgeoning market for clinical chemistry (“diagnostic”) reagents. The first product requested was a solution of copper sulfate for use by the Red Cross at [blood donation](#) sites. When a drop of blood is gently placed into a deep-blue copper sulfate solution of just the right concentration, if the patient’s hemoglobin is high enough, it will be heavier than the solution and sink to the bottom (copper in the solution reacts with proteins in the blood to form an enclosing “bag” around the drop so it can float or sink without dispersing). I made the solution, but resisted my supervisor’s request that I stick my finger. Because I was never able to do it, the carefully-prepared flask of copper sulfate solution sat on a bench top in my laboratory until after I departed in 1965.

² The first one I used was LifeScan’s original Penlet®, which used a single spring to both direct the point toward the skin and return it after penetration. While it seemed like a good idea for low cost and ease of manufacture, there was an unexpected consequence of the single spring: the lancet oscillated back and forth after firing, causing the sharp point to penetrate the skin several times before the motion finally stopped. I had seen this in my own finger (multiple tiny cuts in the tissue could be seen under a microscope after lancing with the device), and had to prove it to skeptical engineers by moving the device rapidly across a

“improvement” in lancing was a laser-based device originally developed in Russia and marketed here by Cell Robotics, but it was quite bulky, made a loud noise when used and did not gain widespread acceptance.¹

Modern lancing devices have improved further, and most now feature adjustments to control depth of penetration of the needle (stoneworkers will need a deeper puncture to find blood than people who don’t work with their hands). Needles are smaller and sharper, and recent devices have been approved for “alternate site testing,” (obtaining blood from the forearm, upper arm, back of the hand, thigh or calf); but ask those who test their blood glucose, and many will say that it still sometimes hurts and can cause bruising. Add the natural dislike of needles to the actual pain produced, to the social unacceptability of droplets of blood and bloody test strips and meters (and concerns about blood-borne diseases), and it’s easy to understand why people have long looked for a measurement that doesn’t involve blood.

In the blood glucose monitoring industry, it is well accepted that there are three “C” terms that drive people’s willingness to test: Cost, Comfort and Convenience. The comfort (pain) advantage of a noninvasive technology is easily understood, and since very few proposed noninvasive approaches need a test strip that is consumed every time a test is performed, there should be a clear cost advantage to both customers and insurance companies alike. The cost of meters, however, would most likely increase with a successful noninvasive approach—the projected cost for common noninvasive approaches varies from several hundred to several thousand dollars.² Convenience includes such issues as how long a test takes, how obtrusive or visible the apparatus is, and whether a visible drop of blood is required to perform the test. This issue is more

pad of writing paper as it was fired. When the top sheet of paper from the pad was held up to the light, multiple holes from the needle tracing the path of movement were clearly visible.

¹ In addition, one of my colleagues from LifeScan says he will never forget the faint smell of burning flesh and discomfort that accompanied its use.

² Most medical insurers, including Medicare, now reimburse patients for the cost of meters and test strips (with different reimbursement levels for type 1 and type 2 diabetes), but many patients have to make the initial cash outlay and then apply for reimbursement.

subjective and deals with the comfort level people have about testing in public, letting everyone know they have diabetes, and concerns about the sight of blood.

LifeScan's attitude toward noninvasive measurements was initially motivated by appropriate, if not entirely noble reasons.¹ The company's growth had been driven by a powerful technological breakthrough, the One Touch strip and meter, and they figured that noninvasive measurements would be the next barrier to fall. As a result, they aggressively pursued every opportunity, with the rule that anyone picking up a technology they abandoned would need to spend at least ten times what LifeScan had invested to bring it to reality. As the candidates fell away one after the other, and the same technologies were recycled by new groups who did not know why an approach had failed before, LifeScan began to adopt an attitude much like the other companies: "First, it might be a real opportunity, and it would certainly grow the market for us if we got it; but for sure, if one of the other companies gets it, it will devastate our business. Second, we have a very good, very profitable business, and we're not sure how we would make the same kind of money without a trail of consumable test strips." A similar perspective probably evolved in all the major companies, into more of a defensive posture: "We don't think anyone will ever make it work, but we have to be aware of what all the groups are doing, just in case." This resulted in new technology groups making the rounds of the "big four," describing their approach to an increasingly skeptical technical management team.

Naturally, there was suspicion on the part of the small companies struggling to develop the technologies that a big outfit like J&J might buy up a successful device, and simply put it on the shelf to prevent it from destroying the very profitable business they had built. This concern was heightened because no big company will ever sign an agreement that requires them to market a successful technology coming from a collaboration or acquisition—they might indeed judge that the damage to their bottom line might be more than the help to customers (or, they might succeed with *two* technologies and need to

¹ Since I was on the Management Board of the company from the launch of the One Touch until 1998, I participated in the discussions and decision-making regarding LifeScan's attempts to access these technologies, as well as in their evaluation.

market the better one and shelve the other). To date, all of this is for naught, since no practical noninvasive device has yet been demonstrated.

The dream, however, of most of the inventors and startup companies, is to prove that their technology works well enough to be acquired by one of the big companies, who would then take it to the market, making the founders wealthy. As mentioned, the prospects for this scenario have dimmed substantially in recent years.

Noninvasive Glucose: Background and Definitions

As home blood glucose monitoring became more commonplace from the early 1980s through the early 21st century, there was still resistance to its acceptance by many people, largely for the reason that, no matter how fast the test or how small the blood drop, there was no way to obtain a sample other than to stick a needle-sharp lancing device into part of the body to get blood. For all but a few, this causes pain, fear, apprehension, revulsion or other negative emotions, and many people just won't do it! There is at least one trained scientist who spent decades working for a blood glucose company conducting clinical trials, including evaluating a variety of lancing devices. As he approached retirement, he was diagnosed with type 2 diabetes. He is on a strict diet, religiously takes his blood glucose lowering medication, but will not stick his finger to perform a blood glucose test.

Considering the romantic notion of devices like Star Trek's Medical Tricorder, with its diagnostic scanner wand that instantly detected and reported everything that was wrong with a damaged crewman or alien, together with the dramatic recent advances in scanning and noninvasive medical therapies, it's easy to see why people have naturally expected that, by now, they'd be able to measure blood glucose without the need to draw blood. The reason they can't is that this has turned out to be one of the most difficult, recalcitrant, obstreperous, and devious problems that has challenged science and engineering.

With the increase in television advertising by some of the major players in the field, many people who do not use the devices mistakenly believe that the problem has been solved. In an attempt to make the devices appear more attractive in the ads, no customer

is ever shown lancing a finger to obtain the drop of blood; instead, the meter is merely shown counting down and displaying a glucose result. “Spokespersonalities” Patti LaBelle and the late B.B. King still have to stick their fingers (or forearms) every time they use a LifeScan One Touch Ultra meter!

Before launching into the history of noninvasive glucose, it’s necessary to provide some classification of the various technologies. There are quite a few where clear categorizations can be made, some where the similarity is a little strained, and some that just fit no category at all. The technical descriptions will be beyond the understanding and outside the interest of some, but they are included to provide the right backdrop for the way various attacks were mounted and why they failed. Readers who don’t enjoy technology should skim the next few technical sections to get to the adventures and storytelling that follow.¹

Also, we need to stop here for a little definition and clarification to understand what will, and what will not, be described. There have been a large number of attempts to extend traditional invasive monitoring into *the most minimally invasive* technologies imaginable. Where the attempts have masqueraded as true noninvasive techniques, they will be covered for completeness. Where researchers have pursued the many implantable sensors, coated wires, and enzyme-covered skin piercing devices, those approaches will be excluded from this discussion. This is not meant as a slight, but as an attempt to place emphasis and scope properly on truly noninvasive approaches.²

¹ During my tenure at Technicon Instruments (now part of Siemens), Baker Instruments (now disappeared in a series of acquisitions by Serono, Amersham, and likely others), LifeScan, a total of 19 years of consulting for many companies in the area, and my brief stint at Fovioptics), I estimate that I have evaluated the approach of almost two hundred groups pursuing noninvasive glucose measurements. Granted, there were not nearly as many *unique* technological approaches to solving the problem, but there were more than that number of researchers, academics, scientists, engineers, physicians, startup companies, and others who took a tilt at this windmill over the same period. Wherever possible, I’ve tried to be generous to those who tried their best, but it’s not possible to be as kind to those whose motives were not as pure. This is of necessity a highly personal (and therefore biased) recounting of all I’ve seen in this arena, and it’s impossible to be fair to all. Also, most of it is filtered through an increasingly imperfect memory, and colored by the strong emotions that inevitably accompany any titanic struggle.

² For example, I first met George Wilson (now Distinguished Professor Emeritus at the University of Kansas) in graduate school at the University of Illinois in the late 1960s. I saw his implantable coated-wire

To be clear about the definition, while insertion of a coated wire under the skin may be minimally invasive, and while it can give continuous glucose readings, it cannot be classified as noninvasive. A recurrent technological theme that inevitably goes by the code name “mosquito,” where *really tiny* needles (e.g., Molecular Devices, [Kumetrix](#)—(long gone), [Sano Intelligence](#), Sahara Energy, Inc., (renamed M Pharmaceutical Inc. in 2014 –with the “[eMosquito](#),”), [Ktrack](#), and Rosedale, now renamed [Intuity](#) Medical,¹ promoting a different approach to blood glucose determination) are inserted into the skin to withdraw small samples of blood or interstitial fluid, can similarly not be classified as noninvasive, and will not be addressed here.

It is also important to distinguish between monitors that can provide continuous readings and those where some patient activity is necessary to perform a test. While some noninvasive approaches seek to perform continuous measurements (*i.e.*, most all the “wristwatch” designs that will be described later), many are too large to wear or would require some preparation on the part of the patient: those are usually referred to as “episodic” (or “intermittent”) monitors. A lot of press has been generated in recent years by companies such as Abbott (TheraSense), Medtronic (originally MiniMed) and DexCom for continuous (CGM) devices where the sensor is implanted under the skin. The advantage of this approach is that, like a wristwatch, it could someday be connected to an insulin pump to achieve the long-sought “artificial pancreas”²—a device that senses blood glucose and administers the amount of insulin necessary for normal control.

To date, the continuous implantable sensors have had their own set of problems, and none is yet reliable enough to connect to a pump to form a “closed-loop” system that could

continuous-sensing glucose technology at the iSense Corporation of Wilsonville, OR in 2004, and I commend him for the decades of dedication, perseverance, and tenacity it took to get the technology to that point. Isense was sold to Bayer in 2008, but reappeared as an independent company again in 2013. After an announcement of an exclusive licensing agreement with Debiotech in 2015, the patents, technology, and the former iSense facility were sold in early 2016 to AgaMatrix of Nashua, NH, and subsequently renamed WaveSense Technologies, Inc.”

¹ In 2016, Intuity finally gained FDA clearance for an all-in-one invasive blood glucose system, with lancing, strips and meter in one case, called “Pogo.”

² In September of 2013, Medtronic received FDA approval for the first version of a partial artificial pancreas (MiniMed 530G with Enlite system) with a “low-suspend” system that stops insulin delivery from a pump when the continuous monitor senses blood glucose values heading toward the hypoglycemic range.

function as an artificial pancreas.¹ As described under the section on “reporter molecules,” anything inserted into the body that does not cause an immediate rejection reaction (this is achieved by constructing it from “biocompatible” materials) will be quickly coated with a layer of protein. As the protein layer builds up, it can gradually reduce the amount of glucose the sensor “sees,” and cause a slower and generally lower response than the actual glucose level. At best, this effect limits the number of days a sensor will live in tissue, and can require that the sensor be recalibrated at frequent intervals with a finger-stick meter. Also, there is frequently a period of time after a sensor is inserted, while the body’s equilibrium settles back down, before reliable glucose results can be obtained. This time varies from one design to another, and possibly from one patient to another.

Once the response has stabilized, most of these devices have also shown periods of time when no valid results are generated, usually called “dropouts.”² The sensor operates properly when bathed in the fluid between cells (called “interstitial fluid”), and if it comes into firm contact with tissue, due to movement or postural changes, access to interstitial fluid can be restricted or cut off. When this happens, the sensor might report very low or even zero values for glucose, and generate a false alarm for hypoglycemia. The convenience of continuous measurements (especially at night, when hypoglycemic episodes are usually not detectable by the patient) is significant, but unless a person is subject to these rapid swings, the cost of sensors and the need to replace them frequently has, to some extent, limited acceptance and continued use. Also, as patients have reported in trials, it may be “too much information”—most minor glucose variations do not need attention, and as one patient remarked, “It’s like having your wife or husband tell you you’re twenty pounds overweight—every five minutes!”

As the first edition of this book was being written in 2006, many of the existing companies were in the process of changing strategy to pursue a new marketplace: post-

¹ The Insulet Omnipod insulin pump system, which has an integrated blood glucose meter for discrete testing, is also “open-loop.”

² A number of patent applications have appeared, primarily from the three named companies, where mathematical algorithms have been devised to replace the missing data with calculated or “projected” glucose values.

surgical or post-traumatic monitoring in critical care units of hospitals. A practice that had been in place for many years, and known widely as the “[Portland Protocol](#)” gained traction in about 2004. It indicated that patients, even those without diabetes, experience wide swings in glucose levels after serious damage to the body from trauma or surgery, and that recovery rates could be improved (and most important to the insurers, hospital stays could be reduced) if patients’ glucose was monitored continuously and the glucose level tightly controlled by IIT (intensive insulin therapy).

At least the following companies began directing at least part of their efforts in this direction, often abandoning noninvasive monitoring for invasive techniques where a sensor (or a catheter inserted into a vein) is changed frequently: Luminous Medical (spun off from InLight Solutions), [OptiScan Biomedical](#), Glumetrics, Glucon and [Echo Therapeutics](#) (originally “Sontra”). Of these, Luminous Medical, Glumetrics, and Glucon are no longer in operation, and some of the [survivors](#)¹ have diverted their efforts toward a product for the European market, where regulatory hurdles are lower. This is partly because there have been reports of increasing risks to intensive care unit patients from hypoglycemia², including increased death rates, when blood glucose is aggressively controlled, and also partly because of increased restrictions placed on the approval of these systems by the FDA.

Techniques such as blister formation, abrasion of the skin to cause fluid leakage, and the like will also not be covered in these pages (with the exception of a “microporation” technique from SpectRx that generated a lot of interest). A closely related technology, reverse iontophoresis, will be described, because it *could* have been noninvasive, and created by far the greatest regulatory stir and patient awareness of any technique with the possible exception of the “Great Biocontrol Fiasco” (see below).

Another problem is that, what is noninvasive to one person is invasive to another. Consider, for example, a frequently-pursued approach: place a small amount of a

¹ Smith, J., Rice, M. [Why Have So Many Intravascular Glucose Monitoring Devices Failed?](#), J Diabetes Sci Technol. 2015, Vol. 9(4) 782–791.

² See NICE-SUGAR Study Investigators, Finfer S, Chittock DR, et al. [Intensive versus conventional glucose control in critically ill patients](#). N Engl J Med. 2009;360(13):1283-1297.

compound under the skin whose (pick one) color, intensity, or fluorescence changes with the amount of glucose in nearby tissue. If it worked, the detection could be done noninvasively, but the act of inserting the compound is invasive, whether it's tattooing or surgical implantation. We'll cover it, but this marks the outer boundary of invasiveness for technologies we will consider.¹ By way of a definition, then, noninvasive blood glucose monitoring should be limited to a technique which produces no pain or discomfort to perform the test, involves no blood or other body fluid obtained by piercing the skin (more on this later), and does not require or cause any tissue damage, injury, or deterioration.

As mentioned, should someone succeed with a truly noninvasive glucose measurement, the payoff would still be huge (although probably reduced from earlier estimates for reasons discussed earlier). Partly for that reason, almost every known analytical or physical measurement technique that could be used to infer the concentration of a substance has been applied to the detection of glucose. In addition, however, there seems to be an unnatural attraction by the obscure, esoteric or unusual approaches. Either in the specific, as described below, or in the general, the less well-known a technique is, the more likely it seems to wind up being applied to the perpetual search for a valid noninvasive glucose measurement. This has led to everything from descriptions of technologies that the presenter clearly didn't understand, to explanations that *no one* could ever understand, to clear attempts to obfuscate and confuse. There have been only a few serious examples of illegal activity connected to regulatory compliance or fundraising, and the marketplace eventually eliminates those with nothing real to offer.

There is another, slightly perverse driving force that keeps companies going in search of the "Holy Grail" past the point where their technological possibilities have been

¹ Note—it is devilishly hard to organize the presentation of what has been tried and why it didn't work. Where only initial investigations have been reported, or a technique only popped up once, I'll include the company or group name in the preliminary discussion of the technology. Where a technology has been multiply investigated, or has been the subject of controversy, I'll give more detail in a later section.

exhausted. Venture capitalists are a strange breed¹ and are motivated equally by receiving large returns on their investments, both for themselves and the limited partners who invest in their funds, and by their reputations among their peers and investors for selecting the most promising new investment areas (having the “Midas touch”). They are cautious, hesitant and unwilling to enter uncharted territory—unless another one has just ventured there. If a prominent firm makes an investment in a company in a new area, other new companies with aspirations in the same “space” receive an unexpected boost in their fortunes as many other investors attempt to jump on the bandwagon. An unfortunate comparison with the fabled behavior of lemmings is common.

The other aspect of the strange behavior of this subspecies is that some, once they have invested, are quite unwilling to admit a mistake, and will provide encouragement for the investigators to continue the pursuit even when the probability of success has plummeted. “Has the opportunity changed?” they will ask, and when the company’s CEO replies that it hasn’t, they’ll often say “Then, keep on trying.” In many cases, they will continue to make follow-on investments in a company to continue the pursuit, in hopes that they may eventually succeed by either developing a product, by selling the company to one of the giants in the industry, or by an initial public offering (IPO) of stock, where they can transfer their losses to new shareholders.

Resources

There are lots of sources, especially on the Internet, where noninvasive devices are described. Unfortunately, most of these are not actively maintained and list outdated

¹ My favorite joke about venture capitalists features one of the breed who died and was confronted by Saint Peter shaking his head at the pearly gates. “You probably weren’t aware of this, but we have a quota system in heaven, and we’re currently at our limit for venture capitalists this month, so I’ll have to send you below.” the newcomer was told. Nonplussed, the sharp-witted investor saw an opportunity: “If I can create an opening by getting someone to leave, can I have his space?” Saint Peter said he didn’t see why not, so the VC asked to use the Heavenly Microphone to address the angels. In a booming voice, he called out, “The cure for cancer has just been discovered in the southeast corner of Hell!” Immediately, a parade a VCs began running down the stairway in pursuit of a great new investment opportunity. As the last one passed, the new arrival fell in line and pursued them down the stairs. Saint Peter grabbed his arm, asking “Where are you going? I thought you wanted to create a place here in heaven?” “Yes,” he replied, but when I saw people from Kleiner Perkins, MedVenture, and Khosla Ventures going by, I decided there must be something to it!”

descriptions of prototypes or press releases from years past. One that is generally updated is Mendosa on Meters (<http://www.mendosa.com/meters.htm>), part of a comprehensive set of websites put together by [David Mendosa](#), a freelance writer and consultant. David has type 2 diabetes, but makes no pretense of being a technical expert, and lists what the companies have stated they are doing, or hope to do.¹

There are other good sources of information that require subscriptions. The first is “[Diatribes - making sense of diabetes](#)” (free!), written by Kelly Close, a financial analyst and consultant to the healthcare industry, who also has type 1 diabetes. For those serious about the subject, there is also a paid subscription publication, [Closer Look](#). Another is [The Diabetic Investor](#) (\$825 for one year), written by David Kliff, an investment advisor, who was diagnosed with type 2 diabetes in 1994. David has followed the history of noninvasive monitoring and writes with quite a cynical eye toward claims made by the companies participating in this market area, especially those with noninvasive technologies. One of his well-known assertions about this field is that “you can steal more money with a PowerPoint presentation than with a gun.”

There are several publications that attempt to inform people about progress in noninvasive testing, but most have a poor track record for accurate or timely reporting. It is recommended that any report in either the popular press or diabetes magazines be viewed with caution, since most have been written either by paraphrasing an overly-enthusiastic press release or following an interview with a researcher excited by the early promising results of a new technique. Similarly, since a search of the YouTube site for “noninvasive glucose” will yield a number of video demonstrations of supposedly working systems, these definitely need to be viewed with skepticism, especially ones where the inventor sticks his finger into a cardboard box and a glucose number appears on an attached laptop computer (such as <https://www.youtube.com/watch?v=RLZhSC-qsUg>).

A book was published in 2010: *In Vivo Glucose Sensing (Chemical Analysis: A Series of Monographs on Analytical Chemistry and Its Applications)*, edited by David

¹ He has also generously hosted the electronic version of this book on his website for over ten years and has referred numerous inquiries from inventors and companies to me.

Cunningham of Abbott and Julie Strenken of the University of Arkansas, which has thorough descriptions of many of the problems involved in developing both indwelling and noninvasive glucose sensors. It has an especially thorough description of the “foreign body response” to materials inserted into the body that is of special interest to those investigating indwelling sensors. Another book, published in 2006, that focuses on one specific technique is *Topics in Fluorescence Spectroscopy Volume 11 Glucose Sensing*, by Chris D. Geddes and Joseph R. Lakowicz, both at the University of Maryland. Another excellent reference published in 2009 is *Handbook of Optical Sensing of Glucose in Biological Fluids and Tissues*, edited by Valery V. Tuchin, CRC Press Series in Medical Physics and Biomedical Engineering.

Scientific publications about noninvasive glucose measurements appear in a diverse array of journals, but one that focuses on them is [Journal of Diabetes Science and Technology](#), published by the Diabetes Technology Society, founded in 2001 by David C. Klonoff, MD, Clinical Professor of Medicine at University of California, San Francisco. The society also sponsors an annual conference in San Francisco each October to November, where many of the potential noninvasive technologies are presented. It is often referred to as the “Klonoff Conference.”

The American Association for Clinical Chemistry, Inc. and the American Diabetes Association published in 2011 their “[Guidelines and Recommendations for Laboratory Analysis in the Diagnosis and Management of Diabetes Mellitus](#),” David B. Sacks, Ed. They stated “No noninvasive sensing technology is currently approved for clinical glucose measurements of any kind. Major technological hurdles must be overcome before noninvasive sensing technology will be sufficiently reliable to replace existing portable meters, implantable biosensors, or minimally invasive technologies.” and in its key recommendations, gave it a grade of “C (very low).”

A review that was good when it was written in 2007 (but dated now) is “Non-invasive glucose monitoring: Assessment of technologies and devices according to quantitative criteria,” in *Diabetes Research and Clinical Practice* 77 (2007) 16–40 by Andrea Tura *et al.* A more recent review, but with less depth and analysis is by Chi-Fuk

So, “[Recent advances in noninvasive glucose monitoring](#),” Medical Devices: Evidence and Research, June 2012 pp. 45–52 © 2012.

An important source of authoritative information is the [ClinicalTrials.gov](#) website maintained by the U.S. National Institutes of Health. Clinical trials that will stand scrutiny are generally posted on that site, and “trials” listed by manufacturers that do not appear there are suspect.¹

There are always “market research” companies willing to sell a summary of what they term “recent advances” in noninvasive glucose monitoring. Examples are [Greystone Associates](#), with a price in 2017 of \$2,850, or Trimark Publications, with a three-page chapter in a report dated June, 2015, of [Blood Glucose Monitoring \(Bgm\) Devices - A Global Strategic Business Report](#), from Global Industry Analysts, Inc., selling for \$4,950.

Another company, Research and Markets, will sell a 38-page [summary](#) prepared in 2009, for just \$188, but the list of companies and technologies is woefully out of date.

A summary of patents in the area “[Non-Invasive Glucose Monitoring Patent Landscape](#)” is available for \$3,217, the fact that all the “featured companies” listed on the website are no longer active in the noninvasive glucose field is less important, because patents can have lifetimes of up to 20 years.

The summaries above are generally aimed at the inexperienced business person seeking an opportunity in this area, rather than at the technically knowledgeable, but the standard of arrogance for all of these was set by the market research company Frost & Sullivan, where their “global team of industry experts and consultants” put together a presentation, developed in 2008 with the amusingly plagiaristic title “Noninvasive Glucose: The Elusive Goose,” which features a person reading long passages verbatim from the first

¹ See, for example, <http://buyersstrike.wordpress.com/2011/12/12/when-is-a-clinical-trial-not-a-clinical-trial-ecte/>

edition of this book¹. In 2015, interested people could still listen to those passages and view the video summary at: <http://www.frost.com/sublib/display-market-insight.do?id=128772297>, but the audio presentation has gone missing in 2017.

An intriguing website is:

<http://www.diabetiker-mailbox.com/noninvasive/museum-noninvasives.html>, curated by Hugo R. Vogel, with pictures of many of the devices shown here, but including two versions of a previously unknown instrument. It is identified as “GluControl,” by the “former MedSci, Shown at Medica in 1994:”

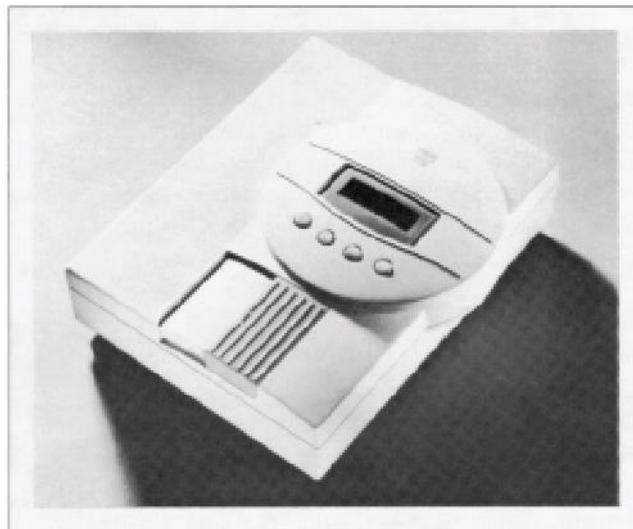

And the same device with a “Samsung Fine Chemicals” label, called the TouchTrak Pro 2000:

¹ When I contacted them following the presentation to find out why they had read extensively from the book without credit, they chose not to respond.

10. Picture of the TouchTrak PRO 200 from Samsung Fine Chemicals February 1998



These devices do not appear to have not been described elsewhere.

Know the Enemy

Anyone who has seen oxygen saturation measured by a fingertip sensor can imagine a similar device placed on the finger, which reads and transmits a signal for glucose to a waiting computer or numeric display. Ah, but the differences between the two measurements, and the two compounds responsible for them! Oxygen saturation is measured by the ratio of the amount of hemoglobin that has oxygen attached to the amount that doesn't have oxygen (appropriately termed oxyhemoglobin and deoxyhemoglobin), and here, the two compounds are of visibly different colors: bluish "deoxy" becomes the bright red "oxy" when a few molecules of oxygen are attached. And, it's the only compound in the body with a strong blue or red color. Not only that, but hemoglobin lives almost exclusively inside red blood cells, all of which conveniently travel inside blood vessels in well-defined paths through the body, and which are subject to pulsatile flow each time the heart beats, making them easier to detect. To make the measurement even easier, the blood of healthy humans contains something like 14%

hemoglobin—that is, each 100 milliliters of blood contains fourteen *grams* of hemoglobin.¹

What about glucose? For such an important molecule, it has the most nondescript characteristics imaginable. First of all, glucose is colorless—not just in the visible region where we see colors, but even if we had near-infrared vision, it would hardly have enough color to see. While it travels in the blood, and changes in concentration are delivered by the bloodstream, it’s also present in all tissues in varying amounts, inside and outside cells as well as blood vessels, and in concentrations which vary from part to part, depending in part on both insulin levels and how long it has been since a meal. The amount? The same 100 milliliters of blood that held 14 grams of hemoglobin normally holds only 0.1 gram (100 milligrams, or a concentration of 100 milligrams per deciliter, usually abbreviated mg/dl²) of almost invisible glucose, and, when the measurement is most critical (in hypoglycemia), as the brain begins to shut down and the body goes into shock, the amount is only half that much. An astounding statistic about the total amount of glucose circulating in the blood is that it is roughly the same amount as the sugar in a packet used to sweeten a cup of coffee (100 mg/dl in 5 liters of blood—50 dl—is just 5 grams of glucose or about one teaspoonful).³

For the chemically curious, the chemical formulas and structures below represent increasingly accurate representations of the glucose molecule.

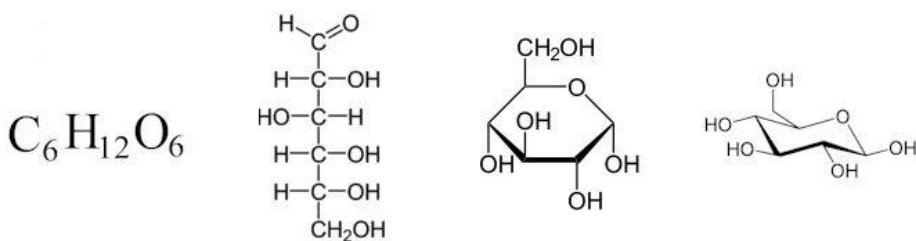

¹ Cercacor has introduced an “[Ember](#)” noninvasive total hemoglobin smart-phone sensor for athletes. They say “Studies have shown that the higher the shift in hemoglobin the more intense the workout,” but dehydration also increases hemoglobin. It is recommended for “elevation training” at high altitudes.

² In many other countries, glucose concentrations are given in millimolar (mM) units. One millimolar is equivalent to 18 mg/dl, and a normal value of 100 mg/dl is about 5.5 mM.

³ In terms of total free glucose in the body, though, there is almost four times that, or 20 grams, since there is about three times as much interstitial fluid as there is blood.

The chemical structure of glucose (and thus its visibility when examined in many regions of light) is very similar to many other compounds that are present throughout the body. Many of the compounds that result from the normal metabolism of glucose have similar structures, as do many intermediates of other biochemical reactions. Even worse, glucose is attached to almost all the proteins of the body (it is this fondness for proteins that causes many of the complications of diabetes when blood glucose isn't well controlled). Albumin, which makes up about 4% of blood plasma, and hemoglobin, which is 14% of blood, both have glucose attached (are "glycosylated"¹) to about 5% of their molecules when a person's glucose is in the normal range, and a similar amount of attachment exists for most proteins. The result is that there are a lot of "glucose-like" molecules in every part of the body, and for most spectroscopic techniques they produce overlapping signals, so it is very hard to tell them all apart. This will be an important consideration when we discuss near-infrared spectroscopy and the difficulty in establishing a calibration using it.

While glucose can be represented as an "aldehyde," only a very small fraction (less than 0.1%) of the molecules are in that form; the majority are in the "cyclic glucopyranose" form shown at the right of the formulas above. This is important, both metabolically and spectroscopically, because it is the aldehyde form that reacts rapidly in the "glycation" (or "glycosylation") reaction² that allows it to attach to protein molecules. Every protein (a complex, folded polymer of amino acids) has one end that is chemically an "amino" group that reacts with aldehydes such as glucose to form an "addition product." This is the reaction that creates the hemoglobin A1c (glycosylated hemoglobin) above, as well as similar compounds involving almost all proteins in the body. Where these proteins have a removal mechanism (the way aging red blood cells are scoured from the bloodstream by the spleen, and the hemoglobin converted to breakdown products that include bilirubin), the percentage of these glycated proteins is fairly small. For proteins like collagen in the skin or crystallin in the lens of the eye, there is relatively little turnover, and the effect is

¹ Glycosylated hemoglobin, often referred to as HbA_{1c}, (or just "A1C") is measured to determine patients' long-term glucose control. It averages the blood glucose values over two to three months and is an accurate predictor of future complications. It is expressed as the percentage of hemoglobin with glucose attached to the total amount of hemoglobin, and a value over 7 percent is generally considered suggestive of diabetes, or at least indicative of poor glucose control.

² This is the same "Maillard" reaction that is well known in cooking as the source of browning when meat with both protein and sugar is heated.

cumulative. The reacted proteins generally lose their physiological function, and result in many of the complications from diabetes, including retinal and kidney damage, and possibly circulatory problems. These long-lived products are often referred to as “advanced glycation endpoint” compounds (AGEs) that can also change to spectroscopic properties, for example, increasing fluorescence of skin.

Noninvasive glucose measurements have been attempted by an incredibly diverse range of technologies; indeed, it seems that almost every technique ever used for analysis has been tried at one time or another. This chapter will later attempt to categorize them according to the technological approach used. This is an imprecise pursuit since different groups use different terms for the same technology and only a few of these are sufficiently well-developed to have standard terminology or nomenclature, but the imperfection of the result should not prevent the attempt.

A Few Notes about Regulations

When the first meters were introduced, there were very few regulations, and they were sold directly by the manufacturers, through doctors’ offices, or by diabetes specialists. In 1976, the Medical Device Amendments were passed by Congress, and devices developed after that date fell into two categories regulated by the Federal Food and Drug Administration.¹ First, those that could demonstrate “substantial equivalence” to a device on the market before 1976 would be approved under a “premarket notification” process known as “510(k),” and could be released as soon as 90 days after filing the proper forms and obtaining clearance. For determination of equivalence, a “predicate device” is selected (which may not have been on the market before 1976, but was approved as equivalent to one that was, allowing devices to be “daisy-chained” over many decades). In the FDA’s words:

A device is SE [substantially equivalent] if, in comparison to a predicate device it:

¹ These two groups generally correspond to what are termed Class II and Class III devices. There is also a Class I category, such as bandages, examination gloves, and hand-held surgical instruments, which is generally exempt from the clearance or approval process.

- has the same intended use as the predicate device; **and**
- has the same technological characteristics as the predicate device; **or**
- has different technological characteristics, that do not raise new questions of safety and effectiveness, and the sponsor demonstrates that the device is as safe and effective as the legally marketed device.

Devices that do not meet this requirement fall into a much more stringently regulated category, requiring a “premarket approval” or PMA. This approval process requires much more strict quality procedures, submission of many more documents, and generally over a year to complete. Ordinary blood glucose meters fall under the 510(k) notification, but a few years back, after several abuses and false starts (see GlucoWatch, Biocontrol and Futrex below, for examples), the FDA decided that all noninvasive blood glucose meters would be handled via the PMA procedures.¹

¹ As Dr. Jean Cooper, an FDA division director told me during a “pre-IDE” informational meeting held with them in Washington, D.C. in 2005 for a noninvasive technology developed by Fovioptics, “You’re welcome to apply for a 510(k) status for your device, and we’ll be happy to cash your second check when you finally submit your application for a PMA.”



Metallic Tractors—Dr. Elisha Perkins' patent metallic tractors, consisting of two rods of brass and iron, were about three inches long and were the earliest recorded fraudulent medical device marketed in the United States. Perkins' tractors were sold to cure diseases by eliminating them from the body. Even George Washington is reported to have purchased a set for his family. By the turn of the 19th century, however, they had been exposed as a fraud. Print courtesy of FDA History Office.

In a 2002 publication, Dr. Steve Gutman, Director, Office of In Vitro Diagnostic Device Evaluation for the FDA, wrote “FDA considers noninvasive and minimally invasive glucose devices that are intended to measure, monitor, or predict blood glucose levels in diabetics to be high-risk medical devices” thus qualifying them not only under PMA, but also as high-risk devices which fall under the Investigational Device Exemption regulations (IDE), as described below:

Many *in vitro* diagnostic (IVD) devices are exempt from the IDE regulations. Under section §812.2(c) of the IDE regulation, studies exempt from the IDE regulation include diagnostic devices if the testing:

1. is noninvasive;
2. does not require an invasive sampling procedure that presents significant risk;
3. does not by design or intention introduce energy into a subject; and

4. is not used as a diagnostic procedure without confirmation by another medically established diagnostic product or procedure;

The PMA process requires more thorough pre-clinical and clinical testing, and the IDE requirements place additional burdens on investigators to determine that their device is safe to use. The pivotal item is number 3—“introduce energy into a subject”—as will be seen below the vast majority of noninvasive technologies do this, and thus have to be carefully evaluated for safety. In order to test on volunteer subjects, the testing protocol must be reviewed by an approved medical body known as an Institutional Review Board, or IRB. This group also evaluates the “informed consent” form that patients must read and sign before volunteering, so that all potential risks from the device are known to them. Largely because people with diabetes are so eager to adopt a noninvasive device, finding volunteers to test them is usually not a problem. And while the volunteers agree to keep the details of the device confidential, very few do, and this is one of the most common ways that information is transferred among companies in this field. This practice would, of course, be much more meaningful if anyone were to succeed in this pursuit, but for the more than forty years that this chase has continued, participating companies have actively sought out volunteers from each other’s studies to learn as much as they can, usually to no advantage other than knowing no one else is on a direct path to success.

Each institution with an IRB generally assigns a member of its medical staff to be the Principal Investigator, and the PI’s responsibility is to help in patient qualification and to provide communication back to the institution. Most are honest professionals who respect the confidentiality of the company’s information, but there are a few who share all they know to anyone who will listen, primarily for self-aggrandizement. The word usually spreads about which investigators should not be trusted with confidential information, at least during the early stages before patent applications have been filed to protect the company’s intellectual property.

The 510(k) and especially the PMA clearance process place requirements on the design, development and manufacturing of a device that are quite complex. The required quality systems, with reams of paperwork for policies, procedures and record-keeping, place a

heavy burden on a small organization, and require huge overhead expenses in the areas of quality assurance and regulatory compliance personnel. As a result, where a creative group can rapidly invent and develop a consumer electronic product in a relatively short time, any company that intends to participate in this pursuit needs substantially better funding at the outset.¹ There is always a judgment call involved in deciding where “research” ends and product development begins, and creative terminology is sometimes involved, because the FDA has adopted the approach that any “prototype” needs to have a complete record (the “Device Master Record”) of how it was designed, developed and tested. For this reason, early versions of a device are often referred to as “benchtop” or “breadboard” research versions, thus avoiding the use of the “p-word” until more certainty of performance is established.

Very early in the process, however, it is necessary to institute a series of procedures called “design controls,” which govern the design, testing and evaluation procedures and establish the basis for the comprehensive quality procedures to follow. Entrepreneurs coming into this field from other areas are often caught unaware by the breadth and depth of these requirements and have difficulties accepting the level of overhead and bureaucracy they place on a small organization. Long before true clinical success is demonstrated, companies also need to plan for manufacturing in an FDA-approved facility, and this adds additional burdens and costs.

Patents

Since patents have played a large part in the pursuit of noninvasive glucose monitoring, and since they are public documents that contain a wealth of information (together with the occasional dose of fiction), throughout this book the patent numbers of issued U.S. patents, or of published U.S. applications, will be listed to which the interested reader can refer for more details. Once the property of a centralized paper collection in Washington, D.C., both patents and published applications are now available on pages under the website <http://www.uspto.gov>, and the search engines “[Google Patents](#)” and [Free Patents Online](#) can find and display most of those in the U.S. patent system, including many

¹ Apple computer, among others, has been widely reported as “not being interested” in devices requiring FDA clearance or approval.

published patent applications and some foreign filings. Those unfamiliar with the arcane language and style of patents may find them hard to slog through, but in many cases merely reading the abstracts will give a fair idea of the material they contain.¹

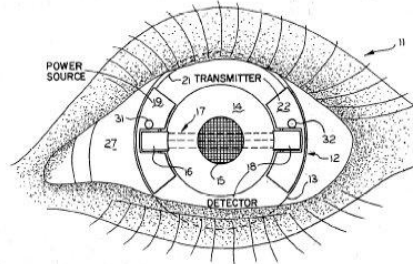

As far as can be determined from the patent records, it all began on November 25, 1974, when Dr. Wayne Front March² filed an application that eventually became U.S. Patent 3,958,560. Amazingly, on the same day, Robert S. Quandt filed a patent application for determination of glucose by almost exactly the same method: rotation of plane-polarized light by glucose in the aqueous humor of the eye! March's patent issued on May 25, 1976, while Quandt's issued on June 15, 1976 as U.S. Patent 3,963,019³.

¹ ¹ In European and Patent Cooperation Treaty ("PCT" prefixed with "WO") patents, an "A" suffix refers to a published patent application, while the same number with a "B" means it is an issued patent. In the U.S., applications (which were first published with a change in patent law in 2001) have a different numbering system, consisting of the year of publication followed by a seven-digit sequential number, then A1. When a U.S. patent issues, it is given a new seven-digit patent number, followed by B1.

² Dr. March also holds the unquestioned record for longevity of publication in this field. His latest U.S. patent, number 7,653,424 "Apparatus for measuring blood glucose concentrations," issued on January 26, 2010. It also describes making a glucose measurement in the aqueous humor.

³ The approach to making the measurement was quite different; I had hoped to someday understand this coincidence of patent filing dates, but Dr. March apparently passed away in 2008, and it may be forever a mystery.

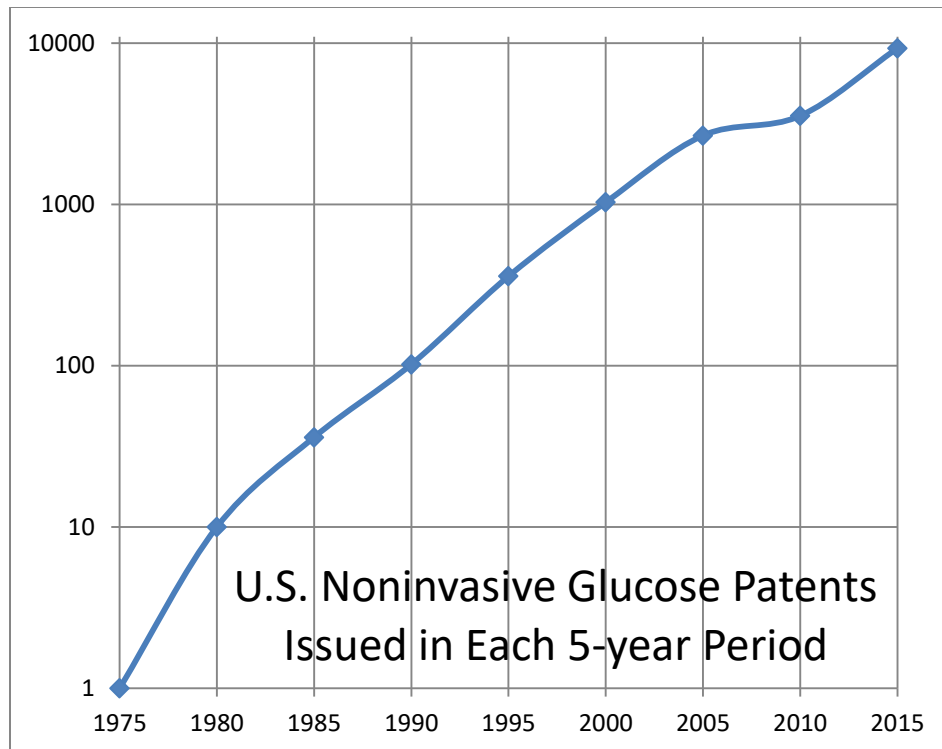

These were two of only about 10 patents in the field that appeared worldwide between 1975 and 1980. As the graph shows, the increase in patents is a remarkably straight line when plotted on a logarithmic scale! The increase in volume is almost an order of magnitude for each decade that has passed since 1975.¹ However, possibly due to the general slowdown in the economy between 2008 and 2012, the number of patents, both applied for and granted, for “noninvasive glucose” declined substantially in those years.

It Ain’t Necessarily So

Those who are not familiar with patents often expect that if something has received a patent, it must work. The only legal requirements for patenting are that the invention be useful, nonobvious and novel—there’s no requirement that it actually work. Because a patent gives the inventor a monopoly for fifteen to twenty years in exchange for “teaching” the world how an invention works or is made, there’s a requirement that the

¹ This is the result of a series of searches for all patents and patent applications issued worldwide under a pair of search criteria: “glucose (and) noninvasive” and “glucose (and) non-invasive.” There are many duplications and many patents that don’t pertain to noninvasive glucose at all, but it shows the overall growth dramatically. U.S. patents make up about 80% of the worldwide list.

disclosure be “enabling;” that is, it must contain enough information to allow a person of ordinary skill in the art to reproduce (“practice”) the invention without undue experimentation. The U.S. Patent system finally harmonized with the rest of the world in 2011 to give priority to the first person to file a patent, rather than the first to think of it or start working on it. It’s certainly not possible to categorically state that no noninvasive patent yet filed will ever yield a commercially successful device, but it is true that none yet has, so it’s best to take all the issued patents and published applications with a grain of salt. They more accurately define what can’t be owned by another person (because someone else already owns the rights to it), rather than what will actually work. Once the patent “monopoly” expires, however, the material passes into the public domain and may be used by anyone.

This situation introduces another complication for the first person who develops a successful noninvasive monitor: with so many issued patents, and the complexity of many of the technologies involved, it is likely that the winner would be greeted with a flurry of patent infringement lawsuits, as the unsuccessful look to cash in on his success. For this reason, the first to succeed will need to have substantial resources to defend the product and might be driven into a relationship with a company with “deep pockets” that can afford the legal expenses that could ensue (see the note about an ironic patent infringement lawsuit against Cercacor, below). The recent rise in “patent trolls,” non-practicing entities who own patents for their value in extorting money from companies rather than practicing any invention, has increased this probability.

Measurement Techniques

Spectroscopic Techniques

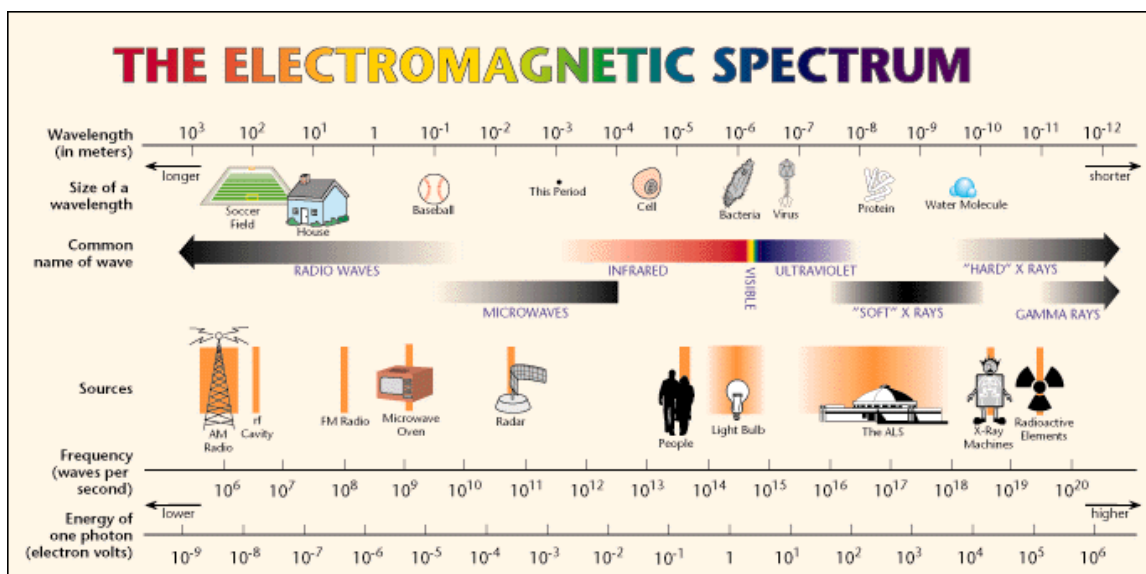

General: Spectroscopic techniques are used to determine the presence or concentration of a substance by measuring how it interacts with light. When light is absorbed in passing through a material, the amount of depletion of the light is measured and termed “absorbance” (this is the inverse of the amount of light passed through, which is referred to as “transmittance”)¹. Under certain circumstances, substances can also give off light, and this is termed “emission.” When the amount of absorption, transmission, or emission is plotted against wavelength, the resulting curve is referred to as a “spectrum.” Each material shows a specific and reasonably unique spectrum, depending on its chemical structure, physical state, and temperature, but the amount of information contained in the spectrum can vary tremendously from one region to another. For instance, when looking for small amounts of water, it’s not a good idea to look at its spectrum in the visible

¹ Another process, called “fluorescence,” involves absorbing light of one wavelength and emitting light of a second, less-energetic wavelength—this is the light that is visible using “black light” bulbs. If the emission of light is delayed for a short time, the phenomenon is termed “phosphorescence.”

region. Even though water has a very faint blue color, there must be a lot of water in one place in order to see it. In the near-infrared or in the mid-infrared region, water has a very intense absorbance (it has a very dark “color,” even though humans can’t see it at this wavelength), and small amounts of it can be easily detected.

Most of the tissues of the body are too thick to allow enough light to pass through for reliable “transmission” measurements at the wavelengths that need to be used for glucose,¹ so an alternative technique called “reflectance” is employed. Here, the light is directed at the surface of tissue, travels some distance into it, and some (usually very small) percentage re-emerges at or close to the site where it was first introduced. To complicate matters, there are two kinds of reflectance: “specular” reflectance, where the light bounces off a shiny surface, as in a mirror, and “diffuse” reflectance, where the light is scattered before it comes back. Glossy white paint acts a lot like a mirror, and the light primarily bounces off at the same angle it hits, resulting in specular reflectance. Flat white paint on a smooth wall yields diffuse reflectance with a reflectance profile termed “Lambertian,” where the reflected light is distributed over a full 180 degrees from the surface.

Tissue is even more complex, since light penetrates to a depth where there are many surfaces (collagen fibers, fat, and cells) which scatter the light, and the result is kind of a “glow ball” of reflected light that comes from below the surface. The technique is complicated because the top surface of the skin also exhibits some specular reflectance, and since this light hasn’t interacted significantly with the tissue, it contains almost no information about glucose.

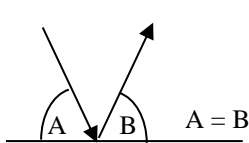

**Specular Reflectance
(Gloss White Paint)**

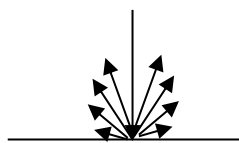

**Diffuse Reflectance
(Flat White Paint)**

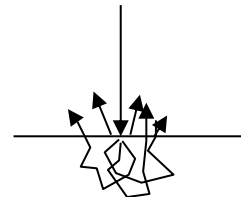

**Tissue Reflectance
 (“Glow ball”)**

¹ The “web” between the thumb and finger, along with the earlobe, are still frequent target areas.

Near-infrared Perhaps the most frequently-attempted (and most trouble-plagued) area is near-infrared spectroscopy. As anyone knows who has held a flashlight under fingers in a dark room, red light (and the invisible band just above it in wavelength called “near-infrared” light) will pass through a considerable thickness of skin and tissue. And as people who have tried to see any bone structure from the transmitted light also know, the light that gets through is very badly confused, or scattered. Light of higher wavelength, usually termed “mid-infrared,” is strongly absorbed by water, which constitutes a very large percentage of all tissues and this light generally can’t penetrate even a hundredth as far. In a cruel trade-off by Mother Nature, the mid-infrared region is quite sensitive and contains a great deal of information about the structure and concentration of chemical compounds, so much so that it is often termed the “fingerprint” region of the spectrum, but light in this region can’t penetrate far into tissue. The near-infrared region, where light does penetrate tissue to a reasonable extent, has more of what might be called “glimmers and ghosts” of structural information—technically, the bands here are called “overtone and combination” bands, and their intensity is greatly reduced below those in the mid-infrared. The upshot of this is a lot like looking for lost keys on a dark night. They were likely lost in an area where it’s too dark to see, and looking under a streetlight where they might be visible will never locate them. An exaggeration, but a fair introduction to the difficulty that attends looking for a molecule like glucose in this region.

For practical purposes, near-infrared light is defined as wavelengths of light between about 600 nm and 2500 nanometers (“nm”—a nanometer is one billionth of a meter; a micrometer is one millionth), so this is the same as 0.6 to 2.5 micrometers, or “microns.” Visible light, generally considered to be 400 to 700 nm, overlaps slightly, but the region below 700 nm contains almost no glucose information, and can safely be eliminated in the search for glucose unless a colored compound has been produced by a chemical reaction. As an example, a technique based on neural network analysis has been reported using He-Ne laser [visible light](#) at 633 nm, and another, using “[wavelets](#)” and neural networks, but the source of any signal related to glucose at this wavelength is unknown.

The ultraviolet region below 400 nm is even more impenetrable, and almost no light at these wavelengths can pass through tissue. Not only is more of the light absorbed by the tissue, but a great deal more scattering occurs. Science class taught us that the sky is blue because short-wavelength light (blue) is more scattered than long-wavelength light (red); in fact, the amount of scattering decreases as the fourth power of wavelength, so blue, violet and ultraviolet regions show dramatically increased scattering.

In addition to the difficulties described above in getting light into and out of tissue, there are two other very serious problems that complicate measuring glucose in the near-infrared. First, because the signal related to glucose is quite weak, researchers working in this area have had to rely on sophisticated mathematical techniques to discern any correlation between their measurements and reference values. Known to chemists as “chemometrics” and to mathematicians as “multivariate techniques”¹ (and generally lumped together into the term “algorithm”²), these approaches generally try to separate the variation within a data set into a series of components or curve shapes which account for decreasing amounts of the observed variability. The need for such techniques indicates a relatively weak or obscure relationship between the measured data and the results sought (or the presence of a number of interfering materials) but by no means indicates that the relationship does not exist. It does, however, indicate that there are many other variables that must be controlled in order for the correlation to be robust.

For instance, a data set obtained with a group of subjects (a “model”) might show reasonable correlation on the day the results were generated. Applying that same model to spectroscopic data for one of the subjects obtained on a different day, when conditions or the patients’ physiology have changed, might give a glucose result of minus 2,000 mg/dl—clearly not a meaningful result, and a good indication that some essential parameters are missing from the calibration model.

¹ One expert in the field describes his research as “Harmonious and Parsimonious Multivariate Calibration: The Tao of Analytical Chemistry.” Another memorable presentation was made by an interview candidate at a noninvasive company who titled his presentation “Multivariate Measurement Techniques: In search of the best wrench to hammer in the screw.”

² While seeking funding for Fovioptics in 2005, I was congratulated by a potential investor, who said our presentation was the only noninvasive glucose “pitch” he had heard that hadn’t used the word “algorithm.”

Another consideration that is little appreciated by many investigators, is that multivariate techniques necessarily produce an “error band” for the results that has a constant error—that is, if the error at 300 mg/dl is 30 mg/dl (quite acceptable), it will also be 30 mg/dl at 60 mg/dl (not acceptable), and could give results anywhere from 30 mg/dl to 90 mg/dl if the true value were 60 mg/dl. What is desired is a “funnel-shaped” error band, where the error is proportional to the value, rather than constant. This result of multivariate data treatment techniques has defeated a number of approaches that initially looked promising.

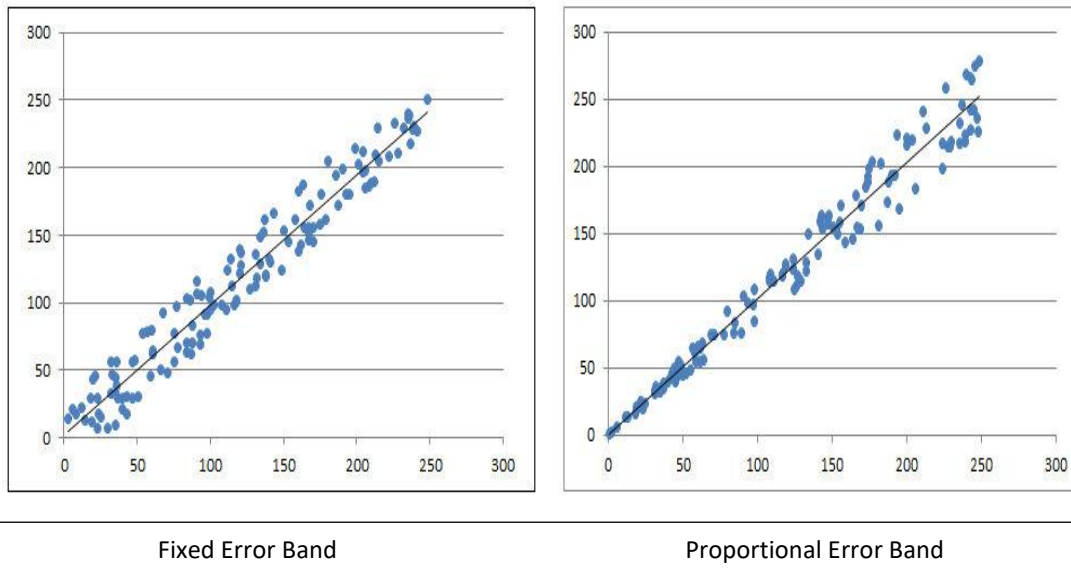

In the absence of “sharp” peaks or other spectral features which are easily distinguished from each other, it is generally accepted that these techniques will work well for signals that are on the order of one part in one thousand of the overall signal ($1:10^3$). There have been estimates, though, that glucose contributes only a few parts of one million of the overall NIR spectroscopic signal ($1:10^6$).

Second, while glucose is the primary fuel and circulates in perhaps the highest concentration of any sugar-like molecule, there are hundreds of “poly-hydroxy carbon compounds” in the body (both inside and outside cells) that are structurally similar to glucose and, therefore, have strong spectral similarities. Like glucose, these substances vary in concentration—some in concert with glucose, some in inverse relationships, and some randomly. As a result, the near-infrared region is a veritable “jungle” of weak,

overlapping, varying signals that come from all these compounds, further complicating the mathematically-based search for the true glucose concentration, and increasing the chances that something whose concentration (if only for a short time) falsely correlates with glucose will confound attempts to isolate it from the overall background. These are known as “spurious” correlations¹ and have cost investigators and their investors untold millions of dollars. Further specific examples of issues and problems will be described when the researchers and their preferred techniques are discussed later.

Measurement in the near-infrared region is complicated by the scattering effects of tissue described elsewhere. When light that enters tissue is not fully reflected, the loss may be due to absorbance by glucose (or other compounds), or the light may have been scattered so many times it was not able to return to the surface. Absorbance of light by compounds is a function of both how strongly the light is absorbed (the “absorptivity”) and by how far the light has traveled (the “path length”). Depending on the degree of hydration, electrolyte balance, or even temperature, the same tissue site can exhibit varying degrees of scattering, and it is exceptionally difficult to separate out the light lost by scattering from that absorbed by glucose molecules. Worse yet, the effective path length of light in tissue is altered by the amount of scattering, so variations can alter the effective amount of glucose that is “seen” by the light and can cause variation in the apparent glucose signal that is not related to concentration.

Generally, however, the spectrum of tissue in the near-infrared region is dominated by the spectrum of water, and since living tissue can be seventy to eighty percent water (and since glucose and water have similar absorptivities, which means that the same number of atoms of each will absorb about the same amount of light), this is a major reason a glucose signal is hard to see. The picture below is an idealized version of the near-infrared spectrum of water (artistic license has been taken to emphasize the effect).

¹ Because the signals are inevitably very small, environmental effects turn out to be common sources of spurious correlation. The domination of the near-infrared spectrum by water vapor means that variations in room temperature and humidity were found on many occasions to be the actual source of observed “correlations” with patients’ glucose levels.

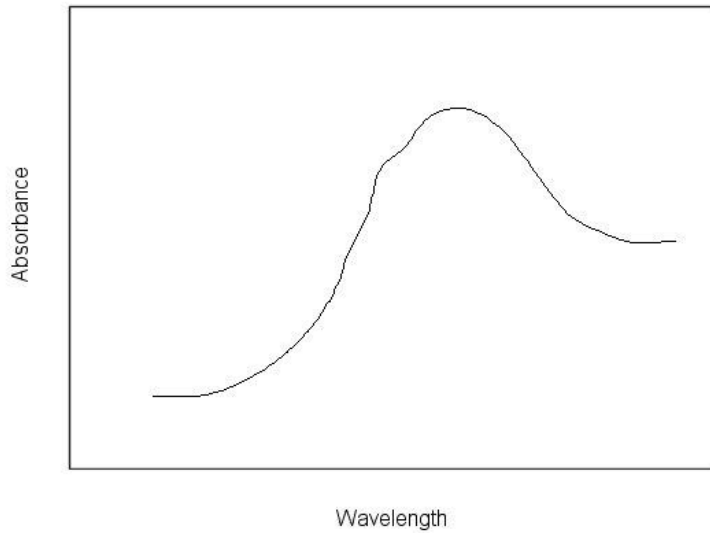

Idealized spectrum of water in the near-infrared

If a solution is prepared containing 10% glucose in water (100 g/l, which equals 10,000 mg/dl or 100 times the amount in blood), the resulting spectrum is shown below.

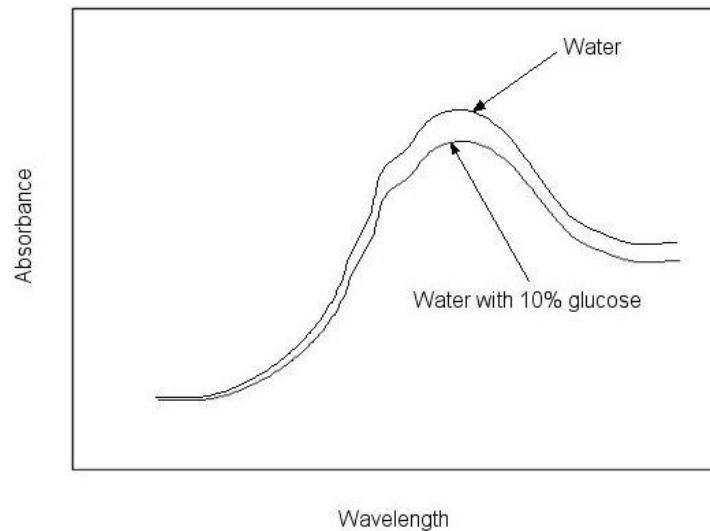

It is evident that, while there is a difference between the two spectra, by far the biggest difference is a decrease in the amount of water, not the presence of glucose. This can be demonstrated by subtracting the spectrum with glucose from the one for 100% water, and examining the difference:

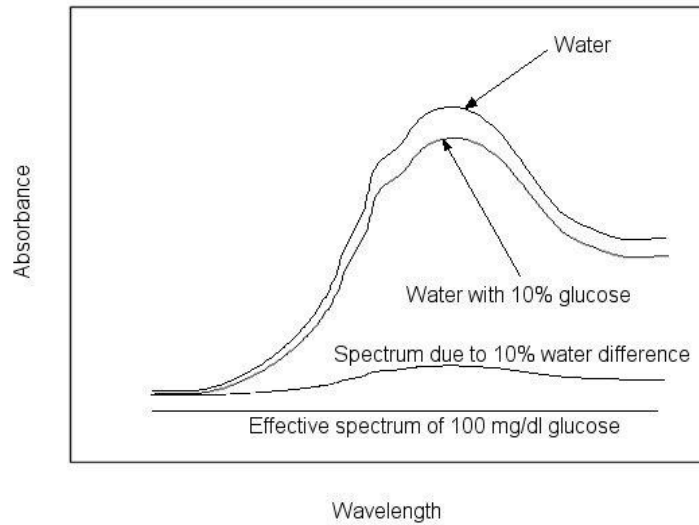

The difference has the same general shape as the water spectrum, showing that there is very little effect from glucose. In fact, on the same scale where 100% water shows a peak most of the way up the graph, the normal 100 mg/dl concentration of glucose in blood or tissue is invisible and would trace out as the straight line shown.

Moreover, in practice, the situation is even more difficult because even in the same person, minor variations in location on the skin, temperature of the skin, or small differences in the pressure of a sensing element applied to the skin (or even how long it has been in place) can cause substantial variation in the appearance of the spectrum.

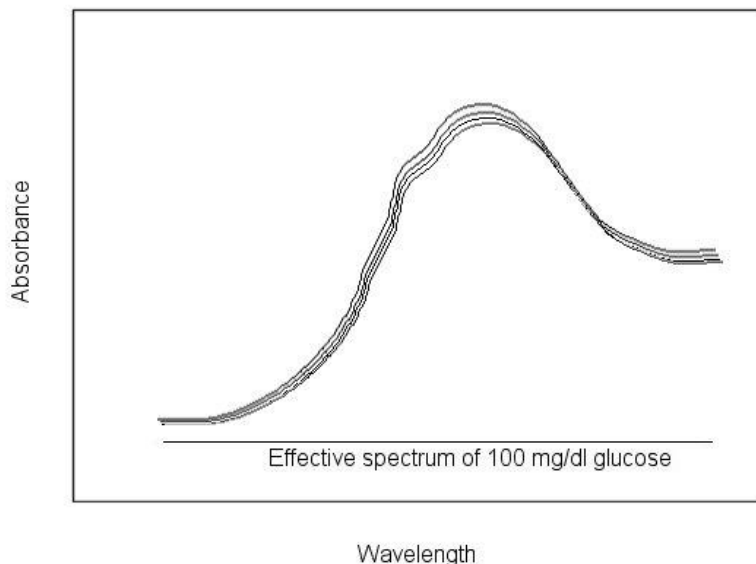

Here, three spectra are shown with overall variations of about 5%; experience has shown that on multiple days or in multiple subjects, the actual variation will be much higher. Again, the contribution to the spectrum from glucose is not only less than the normal variation seen in repeated spectra, it is in fact thinner than the ink line used to trace out each one—almost an invisibly small effect. The result is that there are sources of variation in the spectra that are many times (in fact, many orders of magnitude) larger than the variation due to glucose. Some variations are from other compounds, as described, but even if those didn't vary, because the concentration of water is more than 10,000 times the concentration of glucose, a small shift in hydration will overwhelm variations of glucose. With inanimate, nonvarying samples (semiconductor wafers, gasoline mixtures, or a sample of exhaust gas), changes as small as the glucose effect have been teased out in this spectral region using sophisticated mathematical techniques, but the fact that glucose measurements must be made on live humans, with their inherent movement, plus variations in biochemistry and physical states, has colluded with the small magnitude of the actual signal to prevent an accurate, reproducible near-infrared measurement to date.

Not all compounds are as hard to measure in the near-infrared as glucose. Ethanol, or ethyl alcohol (which taunts us again by being easily measured in breath), which can be present at about the same molar concentration in tissue fluids as glucose, has a much stronger absorbance in a region of the spectrum where few other molecules complicate the measurement, and has often been used as a demonstration of the capability of measuring glucose.¹ It is also a smaller molecule and quite different in its physiological behavior, because it freely passes across the body's membranes and appears in saliva in amounts comparable to that in blood². Several investigators have developed accurate alcohol monitors using near-infrared spectroscopy, but interestingly, none has yet been commercially successful.

¹ More than one investigation for blood glucose measurement has been undertaken because alcohol, unlike glucose, was easily detected across the skin or in saliva.

² In the 1980s, LifeScan had developed a saliva alcohol monitor called AlcoScan, using test strips and a meter similar to that of its glucose monitor. It worked well, but the market opportunity was much smaller than that for glucose, and it was abandoned after the unprecedented success of the One Touch glucose systems in the marketplace.

Probably because of the large dependence of near-infrared signals on temperature, several groups discovered that better results could be obtained if the tissue was warmed before measuring, either to increase the flow of blood to the area or to remove differences in glucose levels among different tissue fluid compartments. It also has a significant drawback, as stated in one of the many patents:

Unexpectedly, it was found that if the temperature of the blood in the cuvette was elevated to around 40°C, the amplitude of the light beams transmitted to the photodetector 7 increased considerably for both the test and the reference beam. This is extremely beneficial in terms of sensitivity of measurement of glucose concentration in the blood sample, and a cuvette heater 10 was therefore incorporated in the apparatus. However, to meaningfully compare sample with sample, the temperature at which the measurement is made has to be constant and identical in each case.

The Reference Problem

Another complication of measuring glucose in tissue is what to compare the result with. When a finger stick measurement is made for a reference glucose value, the glucose concentration there is that of the actual blood glucose (there is a small difference between glucose levels in blood in arteries and veins, with capillary glucose generally being closer to arterial), while the glucose level in the tissue that surrounds the capillaries in tissue regions outside the fingertip will often be different, with changes more slowly followed. The glucose level equilibrates slowly from blood to tissue, depending on the level of circulation and movement because of distance from capillaries and variable diffusion rates.¹ The majority of glucose in tissue, rather than being contained in blood, is in the interstitial fluid between cells, and the concentration there changes more slowly and is often much different from the blood glucose value. In about 2000, TheraSense (now part of Abbott Diabetes Care) was among the first to obtain permission from the FDA for what is called “alternate site” testing—drawing blood samples from the arm, leg, or abdomen instead of the more sensitive fingertip (because so much sensory information is obtained from the fingertip, that area is well perfused with blood, but also has a very

¹ The vast majority of peripheral circulation in tissue serves to maintain temperature in the extremities rather than supplying nutrients such as glucose and oxygen—ambient temperature variations can cause substantial variations in the amount of blood flow and perfusion of tissue, and thus variations in the rate of equilibration between blood and interstitial fluid glucose.

large concentration of sensory nerves). The required disclaimer for testing glucose from these locations is that it should not be done shortly after eating, vigorous exercise, or administration of insulin, due to the expected differences in glucose concentration under these circumstances. In addition, alternate-site testing draws blood from capillaries near the surface of the skin as well as the interstitial fluid surrounding them, and the fluid analysed for glucose there is probably a mix of these two liquids.

Near-infrared (and other spectroscopic techniques that measure tissue) will “see” mostly the glucose in interstitial fluid,¹ not blood, and since it is very difficult to measure the glucose concentration of interstitial fluid, there will always be an unknown difference in concentration from either a finger stick or venous glucose reference measurement that will limit the ultimate measured accuracy.² To date, no spectroscopic method has been accurate enough to be defeated by this difference, but it must be kept in mind for any tissue glucose measurement.



¹ Interstitial fluid is often thought of as being a uniform fluid slightly different from plasma, but in fact, it is a collection of immobile fluids, of sometimes very different composition, that surround the cells throughout the body.

² If there are two sources of error when determining overall accuracy (such as comparing noninvasive glucose measurements to reference glucose measurements), the errors don't add together, but combine in what's called an “R-M-S” or “root-mean-square” fashion: if the error of a noninvasive measurement was 30 mg/dl, and the error of the reference measurement to which it's compared was 20 mg/dl, the errors would combine as the “square root of the sum of the squares:” $\sqrt{(30^2 + 20^2)} = 36$ mg/dl, so even a 20% error from a blood glucose meter reference would degrade the measured accuracy of the noninvasive technique just from 30 mg/dl to 36 mg/dl. When making critical measurements of accuracy, the reference error should be kept as small as possible to avoid this additional source of inaccuracy.

Misinformation. A company selling near-infrared spectrometers ([Pyreos](#), at the Scottish Microelectronics Centre in Edinburgh), was proud to provide this “Non-invasive Diabetes Monitoring Overview: Infrared spectroscopy is a well-established and documented method of monitoring blood glucose levels. Medical publications document its use with blood, saliva and urine. By reducing the size, cost and weight of infrared spectrometers, Pyreos has enabled their use as personal medical diagnostic products including their use as non-invasive diabetes monitoring devices” Readers who have completed this book (or had any connection to a company trying to make this measurement) might disagree, but Pyreos also has another technology interest: “Our sensor products also enable medical bidets, which can provide instant electronic urine test results, giving detailed, daily pictures of blood glucose levels.”

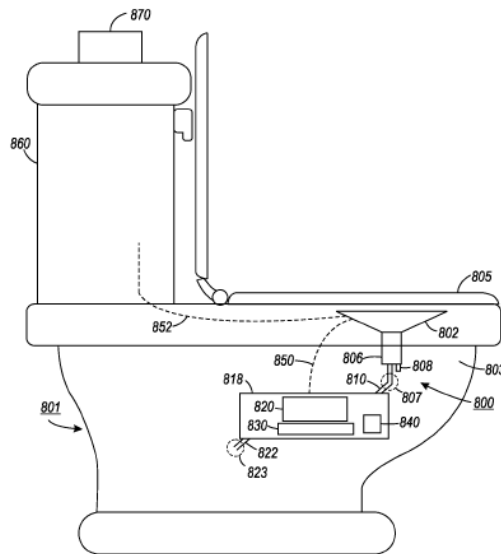

FIG. 8

Urine Testing: A U.S. Patent application was published by researchers at the Palo Alto Research Center, US 2015/0359522, for a “Point of Care Urine Tester and Method.” No details of the detection technology are provided, but the detailed diagram above is provided. A similar device called [Glucosalarm](#), which is smartphone enabled, has also been described.

Mid-Infrared

The mid-infrared is usually considered to be light with wavelengths of 2.5 to 16 micrometers, and often referred to by a reciprocal unit, wavenumbers, where the wavenumber, recited in reciprocal centimeters (cm^{-1}), equals 10,000 divided by the wavelength in microns. The equivalent region (going from the short to the long wavelength end) is about 600 to 4000 cm^{-1} . The technique has been explored for noninvasive glucose measurements, but so far without success. A recent entrant in this field is [Alethus](#), in Boston, MA, with U.S. Patent 8,406,856. Another is indicated by U.S. patent 8,541,743, issued to Roc8Sci Co., now renamed [Memiray, LLC](#).

Oculir: This company was founded by John Burd, who has long experience in traditional monitors (LXN Corporation) and continuous sensors (DexCom), and has been a longtime observer of the noninvasive glucose world. He both founded and closed down a noninvasive company called Oculir (which attempted to measure glucose in the conjunctiva of the eye by reflectance of mid-infrared light from a quantum cascade laser), and it appears from patent claims that the conjunctiva over the sclera (white of the eye next to the iris was the preferred target).

In late 2007, Oculir determined that their approach would not yield acceptable clinical results and closed down the company. A 2010 press release issued by “[Brain Tunnelgenix Technologies Corp](#)” (BTT) stated that the PTO had held all claims of Oculir’s U.S. Patent 6,958,039 to be invalid, and that “final rejection” caused the company to close down. BTT was founded based on the discovery of a “new organ” for temperature measurement by Marc Abreu of Yale University. Abreu, an ophthalmologist at Yale University, has many issued patents for noninvasive measurement of glucose in or near the eye, dating back to US 6,120,460 in 2000. The USPTO Public Patent Application Information Retrieval (PAIR) site, though, indicates only that the Oculir patent in question expired due to nonpayment of maintenance fees.

Another company, SMS Swiss Medical Sensor AG, from Baar, Switzerland, also uses the now-universal quantum cascade laser as a source (US 2016/0143564). Here is a passage from that application (Paragraph 0043) with at least four major errors:

“The tuneable excitation source is preferably tuned in a pre-determined spectral region [8.5 μm to 10.5 μm] which comprises one or more peaks in the D-glucose absorption band, preferably in the IR region, since in this region, the glucose absorption bands are sufficiently distinct and the penetration depth of the coupled-in radiation is sufficient to reach the capillary vessels at 1.5 μm to 2 μm depth.”

First, almost all the glucose in tissue is in interstitial fluid, not capillaries; second, the capillaries are at depths of 1.5 to 2 millimeters, not microns; third, light of this wavelength range will not penetrate to the depth needed to reach either fluid; and finally, any light of these wavelengths penetrating tissue will be absorbed almost entirely by water, obscuring any glucose signal.

A company that made a brief appearance is Rare Light, Inc., which uses a specific angle of illumination of mid-infrared light into tissue for what is described as “peri-critical reflectance spectroscopy” in a patent, US 8,730,468. The company still has a [LinkedIn page](#), but no other signs of life. The technology may have been acquired by Apple during their investigation into noninvasive glucose measurements.

An announced measurement from Scientists at Princeton University (Noninvasive *in vivo* glucose sensing on human subjects using mid-infrared light, Sabbir Liakat, et al., “Noninvasive *in vivo* glucose sensing on human subjects using mid-infrared light,” [Biomedical Optics Express 5:7, 2397](#)), was given wide reporting and included the “trending” quantum cascade laser mentioned below. Close examination revealed that the approach, using multivariate techniques, was not particularly sophisticated or likely to yield a noninvasive glucose monitor.

Another technology in this region, using femtosecond pulses, has been patented (EP 3 037 805 A1) by the Max Planck Society and the Ludwig Maximilian University of Munich. The equipment needed to generate these pulses, however, is large and expensive.

Mid-Infrared Emission

Any material with a temperature above absolute zero emits “blackbody” radiation, and the wavelength region is determined by the object’s temperature. As can be seen on the

spectrum chart, “people” are listed as a source for energy in the infrared, with a spectrum peaking about 1000 cm⁻¹ (“10 microns”). Since the glucose molecule both absorbs and emits in this region (even though this light doesn’t penetrate skin well for absorption measurements), there is a possibility that variations in the amount of emitted light could contain glucose information. An early investigator who proposed this was [Jacob Wong](#) of Santa Barbara, California.

One of the long-time survivors, OptiScan Biomedical, originally combined mid-infrared emission with varying the temperature of tissue in order to accentuate small differences in spectra, and Janusz Buchert, with a company named [Infratec](#), promoted a mid-infrared detection approach using emission from the tympanic membrane in the ear canal.¹

[Glucovista](#), about the time it departed from attempts to measure glucose in retinal vessels, filed a U.S. patent application for the measurement of glucose using mid-infrared emission in 2008, and has filed additional applications since then, some describing other approaches for glucose measurement (US 2015/0196233 for NIR transmission). [Efraim Landa](#), who maintains an eponymous website, is chairman and CEO of the company, spelling it “Gluco Vista.”

Stimulated Emission/Stimulated Raman

These are very exotic spectroscopic techniques that attempt to use the interaction of two wavelengths of light in either the near-infrared or mid-infrared regions. They have been investigated by Paul Steffes, a researcher at [Georgia Tech](#).

Raman Spectroscopy

Raman spectroscopy is a technique which can circumvent, to some extent, the high absorption of water in the mid-infrared region. A laser in the visible or near-infrared wavelength region is used to illuminate the sample, and equivalents of many of the mid-

¹ The company that became Integ, an unsuccessful developer of a minimally-invasive approach to monitoring glucose in interstitial fluid, started life as Inomet, which attempted to measure glucose in the tympanic membrane using infrared spectroscopy; but by absorption, not by emission of infrared light.

infrared absorbance peaks are seen as small shifts in the scattered light, all still in the near-infrared region. Unfortunately, the signals obtained using this technique in tissue are of lower intensity than even traditional NIR spectroscopy, and the theoretical advantage has not yet been realized.

A group in San Jose, CA called C8 Medisensors, reported glucose results from near-infrared Raman spectroscopy in a publication in 2009¹ but showed a mean difference from reference measurements of 38 mg/dl, much too high for measurements in the normal or critical low ranges.² At the end of 2011, after a tremendous burst of press coverage which seemed to indicate that C8 had finally “cracked the nut” of noninvasive glucose monitoring, they received a funding round of over \$19M, including an investment by GE Capital and GE Healthcare.³ Shortly thereafter, both the new CEO and CTO departed the company, and John Kaiser, famous for his long-term advocacy for and participation on the Board of Directors of Sensys (see below), became the new CEO. There were rumblings of serious problems, and shortly after John Kaiser also passed away in 2013, the entire operation “imploded” and shut down⁴. It may have been reconstructed as “Redox Biomedical,” but since the listed address is a single-family residence, that is likely a company organized to own/sell off the assets.

Another company, [Diramed, LLC](#), in Columbus, Ohio was also pursuing Raman spectroscopy (together with specialized chemometric data treatment). It was founded by

¹ Lipson, J., et al., *Requirements for Calibration in Noninvasive Glucose Monitoring by Raman Spectroscopy* *Journal of Diabetes Science and Technology*, Volume 3, Issue 2, March 2009, pp. 233-241, published on-line at <http://journalofdst.org/March2009/Articles/VOL-3-2-SYM2-LIPSON.pdf>

² Jan Lipson, founder and CTO, was killed in a tragic bicycle accident in 2010.

³ The participation of funding by big companies with no experience in glucose monitoring is sometimes pejoratively called “dumb money.” In the same way that inventors can become enamored by the prospect of helping people with diabetes (and coincidentally “cashing in” on the result), companies like GE and Motorola have made what turned out to be unwise investments in this area. Apple, Samsung, Google, and Microsoft might seem to be on the same trail, trying to create a watch, phone, or other wearable device that measures glucose noninvasively, but hopefully, these companies have the resources to more thoroughly research the science of the field before making investments.

⁴ One way to see who else is interested in noninvasive glucose is to see where the technical principals go after a company shuts down. An Apple-watching blog, “9 to 5 Mac” reports that Apple hired several experts in the field of noninvasive blood monitoring sensors from C8 MediSensors, and also hired employees who had worked at Senseonics, InLight Solutions, and Masimo. Time will tell if this turns out to have been a fruitful pursuit for them.

Robert Schlegel,¹ a veteran of the blood glucose and diagnostics industry, and while their website says they are “focusing on non invasive detection and real time monitoring of in-vivo human substances,” little has been heard from them recently. The company may no longer be active in this field.

A group² at [MIT](#) has worked in this area for some time. As usual, very promising correlations are shown, but no product has resulted.

A number of other groups around the world have reported efforts to measure glucose using Raman spectroscopy recently, including Nederlandse Organisatie voor Toegepastnatuurwetenschappelijk Onderzoek TNO (US 2016/0235345) in the Netherlands, RSP Systems A/S in Denmark (US 9,380,942), Imec VZW in Belgium (US 9,380,942), Politechnika Gdanska in Poland (EP 3 056 141 A1), Hong Kong Applied Science and Technology Research Institute Co, (EP 3 056 141 A1), and Taiwan Biophotonic Corporation (EP 3 081 163 A2).

Terahertz Spectroscopy

Few of the wavelength regions above the mid-infrared have been extensively explored, with the exception of what is now termed “terahertz spectroscopy.” With a wavelength range between about 1 and 0.1 mm, this region can yield meaningful data for pure compounds or mixtures in large amounts but has yet to be applied successfully to complex biological samples. Researchers at [Cambridge University](#) published papers indicating that glucose might be measured in this spectral region, and the [Spire Corporation](#) in Massachusetts also explored it for glucose measurements, but neither appeared to succeed.

Recently, Intel Corporation has filed for a patent (WO 2016/048624 A1) for a noninvasive glucose measurement in the terahertz region, and [Advantest Corporation](#) in

¹ Jack Kromar was the CEO when I was contacted by the company in 2008; he is no longer listed as part of the management team.

² W. Shih, K. Bechtel, and M. Rebec, Noninvasive glucose sensing by transcutaneous Raman spectroscopy, *Journal of Biomedical Optics* 20(5), 051036

Tokyo has filed a pair of U.S. applications (US 2016/0095540 A1 and US 2016/0095533) for the measurement of glucose in tears in this region.

Millimeter Wave

It wouldn't be fair to leave out the part of the spectrum that creates the greatest airport-scanner visibility into our private lives, and a combination of groups at UCLA, Cal Tech, NASA Jet Propulsion, THZ global, National Chiao Tung University in Taiwan, and Glaxo Smith Kline have published an [article](#) titled "Compact Non-Invasive Millimeter-Wave Glucose Sensor, where measurements of anesthetized rats' ears at 33-37 GHz showed "a strong reduction in MMW power absorption through the rat ear with increasing glucose levels in the blood." Skeptics will anticipate that this, like other RF and microwave impedance measurements, is a response to bulk properties of tissue fluid without specificity for glucose.

Photoacoustic Spectroscopy

This is a scientifically fascinating, but so far not particularly useful technique. Developed by Alexander Graham Bell in the 19th century, it has been largely a solution looking for a problem since that time.¹ Briefly put, when materials absorb visible light, they give it off as heat, through the "greenhouse" energy conversion system called "vibronic coupling," where light energy (more energetic photons) absorbed by a material is given off as infrared or heat energy (less energetic photons). In early versions of the technique, a modulated light beam was used to illuminate a sample contained in a sealed chamber with a sensitive microphone. The release of the infrared energy heats and cools the air at the frequency of modulation, and the "hum" from the sample grows louder in wavelength regions where it absorbs more light and softer where it doesn't. By plotting the intensity of sound against wavelength, a reasonable version of an absorbance spectrum can be generated. More modern systems use pulsed laser light, which is much more intense, and

¹ During the time I was at Princeton Applied Research Corporation, the company briefly marketed a photoacoustic spectrophotometer. Several companies offered similar devices during a brief resurgence of the technique in the 1970s that found use for the devices primarily in academic research programs.

also use more sophisticated signal processing techniques to determine the presence or measure the concentration of a substance.

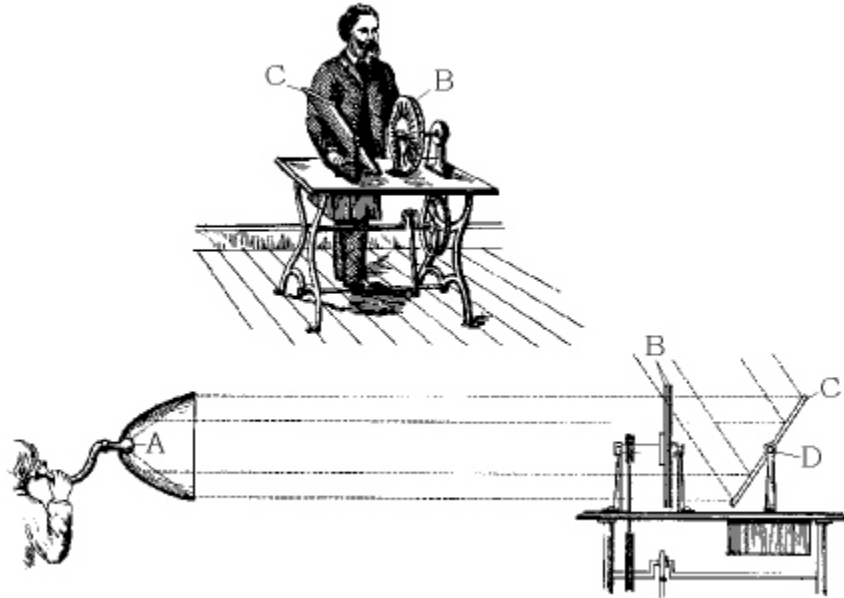

Perhaps because of its exotic name, this technology has been explored (or at least suggested) by the following groups: Herriot-Watt University in Edinburgh, Scotland; [Richard Caro](#) at Serraya in San Francisco; the [Oulu University in Finland](#); TRW (now Northrup-Grumman); Fluent Biomedical; Glucon, Or-Nim, and Nexsense, all three based in Israel, and most recently, Samsung Electronics of Korea and researchers at the Zurich Institute for Quantum Electronics in Switzerland, who combined this technique with a quantum cascade laser, along with others at the Institut für Biophysik in Frankfurt am Main, Germany, [In Vivo Noninvasive Monitoring of Glucose Concentration in Human Epidermis by Mid-Infrared Pulsed Photoacoustic Spectroscopy](#), *Anal. Chem.*, 2013, 85 (2), pp 1013-, who also used this combination of techniques.

Also, [Daylight Solutions, Inc.](#), of San Diego has a patent application (WO 2016/077633 A1) using a pair of lasers for “double photoacoustic” measurement, and Nippon Telegraph and Telephone has an issued patent for the same subject (US 9,198,580).

Plus ça change, plus c'est la même chose—in 2005, U.S. patent application 20050054907A1,¹ based on photoacoustic spectroscopy was published (possibly from Fluent Biomedical), and it included this illustration of a wristwatch glucose meter:

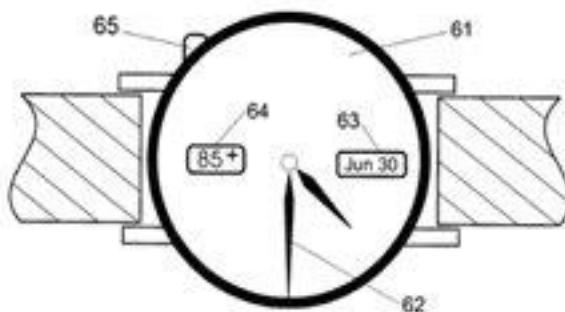

Optical Rotation

While glucose has no color in the visible region, it has a characteristic shared with some other organic molecules (and a few inorganic ones) that causes it to rotate polarized light. This is again a fascinating area of science and heavily stressed in training organic chemists, and has intrigued investigators for decades that it might be measured in the eye. The amount of rotation of light by a compound is called its specific rotation, and for glucose, the figure is $+56.2 \text{ degrees (g/dl)}^{-1} \text{ dm}^{-1}$. This means that a concentration of one gram of glucose in one deciliter (100 ml), with a path length of one decimeter (10 cm or 100 mm), will rotate plane polarized light to the right by 56.2 degrees. One g/100 ml (1000 mg/l) is a factor of 10 higher than normal glucose levels of 100 mg/dl, so normal glucose levels would rotate the light by only 5.6 degrees with a path length of 100 mm. Since a normal path length in living tissue (or the eye) is about one or two millimeters, it's necessary to divide by another factor of 100 to get the amount of rotation in one millimeter: 0.056 degrees for the entire signal. Detecting a change in concentration of 10 mg/dl would require an accuracy of measurement of 0.0056 degrees. This is a very small amount of rotation, but this limitation has not deterred the determined, as will be described below.

¹ The application was subsequently abandoned at the U.S. Patent Office.

The most common place to look for glucose with this technique (and probably the second most-pursued of *any* noninvasive technique), is in the anterior chamber of the eye (the space between the cornea and the iris), where a fluid exists that is still known by the archaic name of “aqueous humor.” Because the cornea (the hard front surface of the eye) is transparent, it is theoretically possible to pass polarized light through it to measure how much it is rotated by glucose present in the fluid (although the measurement is also complicated by the cornea, since it is “birefringent,” which means that it exhibits multiple refractions of polarized light and scatters the light into two paths).

Perhaps more important, there are dynamics of formation and mixing of the aqueous humor that dramatically complicate any measurement for glucose made in this medium. In an 84-page comprehensive review by R.F. Brubaker, entitled “Flow of Aqueous Humor in the Human Eye” (Trans Am Ophthalmol Soc. 1982; 80: 391–474), the author states the following:¹

In a series of 113 normal subjects¹⁰⁹ ranging in age from 20 to 83 years, the mean (\pm SD) value of the anterior chamber loss coefficient of fluorescein was $1.5 \times 10^{-2} \pm 0.43 \times 10^{-2} \text{ min}^{-1}$. The volume of the anterior chamber in these eyes was $186 \pm 37 \mu\text{L}$. The calculated rate of clearance of fluorescein from the anterior chamber was $2.7 \pm 0.6 \mu\text{L}/\text{min}^{-1}$. The rate of aqueous humor flow through the anterior chamber was calculated to be $2.4 \pm 0.6 \mu\text{L}/\text{min}^{-1}$.

This means that the amount of fluid produced *per minute* is approximately one one-hundredth the total volume of the aqueous humor, and the glucose concentration of the aqueous humor changes at most one one-hundredth as fast as that of the blood. The calculations that give the amount of time for a new blood glucose value to equilibrate in the aqueous humor are complicated, but the result is a delay of about 45 minutes to one hour between a measurement of glucose in blood and an accurate reading of a changed glucose value in the anterior chamber, which would be much too long a delay for a person whose glucose level was approaching dangerously low levels, and could probably

¹ In fact, on page 433, Table XIV summarizes nineteen studies performed over a thirty-year time span, in which the flow rate was estimated at between 1.9 and 3.4 microliters/minute for all studies.

never monitor short-term glucose trends.¹ Depending on the optical system used, either the anterior chamber (just the volume between the cornea and the iris, indicated as “A” on the figure) or the total volume of aqueous humor contained in the anterior chamber and the posterior chamber (the space between the iris and lens, “P”) may be examined. The total volume (anterior and posterior) is about 300 microliters, while the anterior chamber itself is just under 200 microliters.

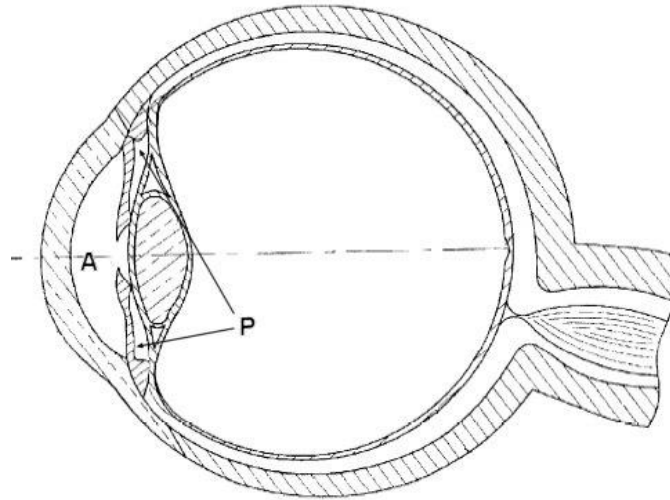

Therefore, even if the glucose inside the anterior chamber could be measured accurately (and so far, no one has managed accurate measurements in forty years of pursuit), it almost certainly wouldn't yield clinically acceptable glucose monitoring results. However, this longest lived of approaches has been explored by at least the following groups (besides March and Quandt, above): Gerard Coté², Martin Fox and Brent Cameron (University of Connecticut and University of Texas), Tecmed, Ed Stark, Vitrophage, Roche Diagnostics, and Abbott.

¹ There have been reports that people with diabetes might have a shorter equilibration time due to leakage of glucose that occurs in the ciliary process (the “blood-aqueous barrier”) where aqueous humor is made from plasma. Other reports indicate that flow of aqueous humor is reduced in patients with diabetes.

² Coté published a [paper](#) in 2001 where he followed the production of aqueous humor in New Zealand white rabbits, and concluded that the glucose equilibrium time could be as short as five minutes. The measurements were made by withdrawing fluid, and this process may have altered the rate of production and led to a shorter estimate of the equilibration time.

Brent Cameron helped to form Freedom Meditech (in Toledo, OH and San Diego, CA) to pursue measurement of glucose in aqueous humor. As of 2017, the company's [website](#) still has a page describing their proposed I-SugarX optical glucose monitor, but seems to be focusing more on a screening technique for diagnosing diabetes based on cross-linking in the lens of the eye (the Clearpath DS-120 instrument) that was an early approach of the Laser Atlanta company that was a predecessor of SpectRx.

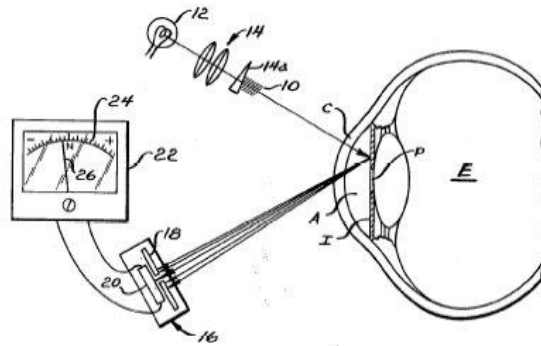

Related technologies, based on variations in refractive index rather than optical rotation of the aqueous humor, were being pursued by at a company originally named Visual Pathways in Anthem, AZ, Ansari (U.S. Patent 6,704,588), and by [Lein Applied Diagnostics](#) in the UK¹. The investigator at Visual Pathways, [Thomas Cornsweet](#), is now the Chief Scientist at Quantum Catch in Prescott, AZ (recently renamed Brien Holden Vision Institute), and had a patent application issue in 2014 directed to the same basic technology. In the five years that passed between the first and second editions of this book, the visible progress on Lein's website was limited to an artist's rendering of a cell-phone-sized instrument. At the time of writing of the most recent edition, all mentions of glucose measurement had been relegated to the "archive" section of the website, but a patent from Lein—US 9,026,188—appeared in May of 2015, suggesting measuring glucose as a function of thickness variations of the cornea, which can be measured optically. A company called Q-Step (originally in Southern California, but later in San Ramon near the Silicon Valley) proposed making measurements of the iris of the eye that could change with glucose variations in the aqueous humor that surrounds the iris.

¹ Lein is, like Robert Rosenthal's "Trebor", a reverse-eponymous version of the founder's first name.

Although it was active as late as 2007, the company appears to have disappeared after a series of management changes. The company's patents did not seem to disclose a particular method of measurement of the eye related to glucose.

Another recent entrant in this field, [IRISense](#), has registered a clinical trial where they state "Previous animal studies done by Dr. Brent Cameron in 2013 at the Univ. of Toledo have shown that glucose present in the fluid in the front of the eye, called the aqueous humor, correlates well with blood glucose. As blood glucose changes, the optical properties of the aqueous humor change, causing a change in the appearance of the iris of the eye. The data collected in this study will be shared with IRISense to assist in validating the algorithm being used to develop the database needed. The data collected so far is in a narrow band of the normal glycemic range (healthy volunteers). We will collect standard digital photographic images of the eyes of subjects with diabetes along with corresponding blood glucose concentrations using the finger stick glucose monitoring method." Unfortunately, the report in October of 2016 was "This study has been terminated. (No positive results were detected)," but unlike so many other investigations, at least the information on this trial has been shared with others.

Optical Rotation in Tissue

The perceived simplicity of this approach lured at least two early groups (Electro-optical Laboratories in Tennessee; Sunshine Medical in Northern California) into the exploration of optical rotation of light by glucose in tissue. However, every time light reflects (scatters) from a surface there is a change in polarization of light, and after a very short passage through tissue, the polarization of the light is random and chaotic. Neither company was able to achieve acceptable results. A third company has recently surfaced, called Socrates Health Solutions, in Dallas, TX, which appears to be using a similar approach by measuring polarized light sent through the earlobe, based on U.S. Patent 8,743,355. It was initially the subject of yet another Indiegogo campaign, but raised only \$1,905 of its \$125,000 goal.

Two companies, both headquartered in Israel, have recent patents for related technologies: T.G.M Technologies Ltd, in Kiryat Bialik splits a beam of polarized light

passed through tissue into two components (US 9,295,419), and Judah Gordon of Jerusalem has a technology, described in US 2016/0367175 for measuring small angles of rotation of polarized light.

Light Scattering

As described, when light passes through tissue (or is directed into it and bounces back out as a reflection), it is strongly scattered, and if well-defined rays entered, they would be jumbled and confused when they exited. It has occurred to several researchers to exploit this relationship, based generally on a single phenomenon: much of the scattering occurs at the interface between cells and the interstitial fluid in which they are bathed. It is based, to a large degree, on the difference in refractive index between the fluid and the cell wall, and the refractive index of the fluid depends on, among other things, the amount of glucose present. In these approaches, as glucose concentration increases, the refractive index increases to become closer to that of the cell wall, and the scattering decreases. The major drawback is that the concentrations of many other substances also vary, and those variations also cause changes in the refractive index of the fluid. The measurement seems to be particularly sensitive to tissue hydration, and since edema (swelling) is a common symptom of people with type 2 diabetes, this could seriously interfere with the reproducibility of the measurement. Also, as described below, tissue hydration can vary with changes in blood glucose, which may both give rise to this approach, and ultimately defeat it because of the nonspecific nature of the measurement.

A slight variation of this theme was employed by a company in Israel named Orsense. They stopped the circulation of blood in a finger for a short time, and watched scattering changes over time caused by a proposed agglomeration of red cells inside blood vessels. They seem to have de-emphasized their glucose instrumentation research in recent years, and the only recent mention of glucose was in a brief repeated section “About Orsense” at the bottom of their press releases that disappeared around 2014, and as of 2017, there was no longer any mention of glucose on their website. The scientists who were conducting the glucose research appeared to have moved elsewhere some time before that.

A further version, also based largely on scattering, is sometimes called “time of flight” scattering, and has attempted to separate the photons that went straight through tissue (“ballistic” photons) without being scattered, and should therefore contain less glucose information, from the other photons that bounced around more and interacted with glucose-containing tissue. As in the mid-infrared region, the equipment to generate the very short femtosecond pulses is large and very expensive. This has been given a boost in recent years by the availability of optical coherence tomography (OCT—see below) systems which effectively separate photons based on the distance or time they have traveled. Several patents have appeared, but no clinical results.

An increase in the scattering of near-infrared light by red blood cells with increasing glucose levels has been reported by Mark Arnold, a long-term noninvasive glucose investigator at the University of Iowa. He states¹ “The observed increase in scattering with higher glucose concentrations would be consistent with either an increase in the refractive index mismatch between the plasma and red blood cells or a reduction in the effective size of the red blood cells.” Since increasing glucose increases the refractive index of the plasma the cells are immersed in, greater scattering would indicate *an even greater* increase in the refractive index of the cells. He speculates that the higher glucose concentration causes an increase in the product formed inside the red cells from the first rapid, reversible step of the “glycation” reaction between glucose and hemoglobin (a slow rearrangement step follows that produces “glycosylated hemoglobin,” that is measured as hemoglobin A1c). Patent applications² appeared in 2012 from a company named Verifica which use this effect for glucose measurement in combination with “differential scattering spectroscopy and confocal scanning laser Doppler microscopy.”

Transdermal Techniques (and other trans-membrane techniques)

Asking a group of people to suggest ways that glucose might be measured noninvasively will inevitably yield suggestions of saliva, sweat and tears, since these are produced in relative abundance and easily accessible. (Ear wax and “nasal exudates,” two other common nominees, are not valid markers of glucose, primarily because of the time period

¹ Analytical Chemistry, Vol. 77, No. 14, July 15, 2005

² WO2012134515A1 and WO2012087319A2

over which they are produced and the fact that they're not always available for examination.) After all, they reason, if urine can give an indication, at least of high glucose, these might work as well. This frequent reasoning error leads to the Second Law of Noninvasive Glucose (even though it's introduced first, it's less important than the First Law which follows some distance below):

Second Law:

It Is Not Possible to Get a Reliable Measurement of Glucose Across an Intact Cell Membrane.

Here are the reasons: On a simplistic basis, any organism that leaked its primary fuel (glucose) across its external surfaces would be a very inefficient organism and would probably have been eliminated by natural selection long ago. For a more sophisticated reasoning, the amount of any substance that travels from fluid on one side of a membrane to the other (this is termed “partitioning”) depends on many complex factors—the concentration of the substance on either side, the presence or absence of mediators (which open the cell wall to a substance; insulin is a good example) or transporter molecules (endothelial cells, which line the surface of blood vessels, do not employ insulin to mediate their glucose transport, but either allow either free diffusion of glucose or employ transporter proteins to “carry” glucose across the membrane). In addition, levels of sodium and potassium (“electrolytes”) can greatly alter the permeability of a cell membrane to a variety of substances. In the skin, where most attempts to measure glucose have been focused, there is a surface layer of dead cells compacted to form the “stratum corneum,” that acts as a strong barrier to passage of glucose.

The body goes to great lengths to produce fluids with the right compounds in them (salt in tears for tissue compatibility, for example, or digestive enzymes in saliva), and to prevent them from carrying away other compounds. In sweat glands, a large membrane surface area is used to collect water and transport it to the surface to aid in cooling, but

glucose and most other molecules larger than simple ions like sodium and chloride are largely excluded from the fluid.

While both tears and saliva contain very low levels of glucose (see below), trying to coerce the cells to do something they don't want to do (leak glucose), may create the effect under duress, but not reliably or at a constant rate. This leads to another principle that has a parallel in quantum physics, known as the Heisenberg "uncertainty principle." The formal definition is a little obscure, but what it implies is that trying to look too closely at a subatomic particle will alter its state, just by the process of looking. The same principle occurs if attempts are made to force glucose to go where nature didn't intend it and leads to the Uncertainty Principal Subsection of the Second Law.

Uncertainty Principle Subsection of the Second Law:

Attempts to force glucose across an intact membrane will alter the local concentration of glucose.

As we will describe in the section on Cygnus, it's possible to get more glucose to appear on the surface of the skin (or across the conjunctiva of the eye, or in the saliva across the buccal membrane inside the cheek), but a lot of force is required, and this force inevitably disrupts the normal equilibrium of that portion of the body. Defense mechanisms are almost always raised (swelling, inflammation, blistering), and these result in very different metabolic states and substance levels than would normally be present, which can alter the local glucose concentration. There have also been attempts to change membrane permeability and allow increased glucose flow by using "natural" substances such as bile acids, but also without commercial success.

In addition, the Directional Principle of the Second Law, as has been learned by companies like Cygnus (reverse inotophoresis) and Sontra (ultrasound), states:

Directional Principle Subsection of the Second Law:

It's easier to get (uncharged) molecules into the skin than out of it.

Transdermal drug delivery (“patches”) has been used to deliver a number of therapeutic agents across the skin. They use materials called “permeation enhancers” which help move the drug molecules, but they also use a very large concentration of drug in the patch. This large concentration helps to drive the partitioning of drug into the skin, and when the patch is discarded, a substantial fraction of the drug remains undelivered. Adding an electric current to transdermal delivery produces a technique called iontophoresis, and it has also been used for drug delivery. Cygnus (with its GlucoWatch) proved just how difficult it is to pull molecules the other direction, especially if they’re uncharged (the glucose molecule is *polar*, meaning that the electric charge is unbalanced from one end to the other but without measures that are intolerable to tissue, it does not ionize into a positively or negatively charged species that would be accelerated by an electric current). It has been speculated that glucose moves through some portions of the skin in concert with sodium ions,¹ but that has not been proved. In addition, the concentration of glucose below the skin is very low, so it does not have the concentration advantage of the drug delivery patches.

The technique of phonophoresis, using ultrasound to increase the permeability of skin so substances like topical anesthetics can penetrate more easily, has also been used for many years, and it has found use for anti-inflammatory drugs and analgesics, mostly for pain management. Abbott learned, in a brief association with Sontra² around 1996 that coaxing glucose out from the skin with ultrasound was as least as difficult as with electricity, if not more so (Bayer learned the same thing when in sponsored Sontra’s

¹ The class of diabetes drugs known as SGLT2 ([Sodium-glucose Cotransporter-2](#)) inhibitors operate on a transporter protein that reabsorbs both materials back into the bloodstream; it is located only in a specific section of the kidney.

² Sontra’s existence has continued on a tortuous path through 2017. After having its research sponsored by Bayer from 2003 to 2005, it announced plans to close down in 2007. It was saved through an acquisition by Echo Therapeutics and continues its existence, issuing frequent press releases detailing its progress.

research in about 2003). Sontra originated in Robert Langer’s lab at MIT, hoping to move glucose across the skin with ultrasound and has become, through a complex sequence of acquisitions and buyouts, Echo Therapeutics.



The revised principle involves abrading off the top layer of skin with their “Prelude Skin-Prep” system, then applying an electrochemical sensor called “Symphony” to monitor glucose for a day, after calibration and warm-up. Some bad press in 2013 about a major stockholder unhappy with the precipitous decline of their stock price resulted in the abrupt departure of the CEO, and may echo troubles ahead for the company. A blog called “Buyers Strike!” has posted several articles casting doubt on the future of Echo, saying “Recently Echo Therapeutics (ECTE), the little reverse merger company that can’t (fill in the blank – get a 510(k) approved, raise money from reputable investors, generate meaningful revenue, run a properly registered trial) [has attempted further dilution of its shares].” Echo may have applied to the FDA for 510(k) clearance of their device as early as 2009, but that has yet to be granted. In October of 2013, Echo announced it had laid off 30% of its workforce, citing delays at the FDA caused by a temporary government shutdown, but still announcing it would start a clinical trial for FDA approval in late 2014.¹ Echo announced in September of 2014: “Echo Therapeutics Inc. has suspended its product development, research, manufacturing and clinical programs and operations to conserve its liquidity and capital resources,” but in March of 2015 a new press release said that it had “achieved its wireless mobile communication milestone, making it now possible for its continuous glucose sensor to transmit data to any mobile platform.” A story in the New York Times in late 2016 indicated more trouble for Echo’s primary investor: “A founder of the New York hedge fund Platinum Partners and six others were arrested on Monday morning on charges relating to a \$1 billion fraud. The men were

¹ There is no record at clinicaltrials.gov of any clinical trial for Echo Therapeutics.

charged with securities fraud and investment adviser fraud in a \$1 billion scheme in which executives used new investor money to pay older investors, according to an unsealed indictment filed in Federal District Court in Brooklyn”

Another pair of companies, Technical Chemicals & Products, Inc., and Americare, both thought they had the ideal transdermal system based on changing permeability of skin with solvents such as ethanol and ether, and battled each other in the press and in court for some years. Neither company launched a product for measuring glucose, but a successor company still exists called Health-Chem Diagnostics¹, which attempted to launch a transdermal “patch” product using propylene glycol as the permeation enhancer, but as of 2017, had removed all material on its website related to these products.

Passive collection of sweat, just like examination of the surface of the skin (by any means—spectroscopic or otherwise), shows only trace and variable amounts of glucose. An idea floated some years ago was to add a “sudorific” (sweat-inducing) compound such as pilocarpine nitrate to the surface of the skin, thereby increasing the flow of sweat from the skin surface (this is done, along with mild electrical stimulation, in what’s termed a “sweat test” to screen for cystic fibrosis, but the test has diagnostic value only because the abnormal level is about 50% greater than normal). Again, it’s a safe bet that, if normal sweat contains no measurable glucose, any that is found after stimulation of the skin will not accurately reflect the amount present in unstimulated tissue. Depending on whether one’s glass is perennially half-full or half-empty, it is possible to interpret the continuing pursuit of these trans-membrane techniques as “hope springs eternal,” or “those who cannot remember the mistakes of the past are doomed to repeat them.” See the section below for sweat techniques that have not produced commercial success.

One fluid (interesting beyond the fact that it’s just plain fun to say) is called “gingival crevicular fluid,” and does have glucose levels very close to plasma. GCF is very slowly exuded between the gums and the teeth, into the mouth where it mixes with saliva.² The very low rate of production makes it challenging to collect, and the very large amount of

¹ Jack Aronowitz, who was the CEO of Technical Chemicals and Products, is still listed as the CEO of Health-Chem Diagnostics.

² It is possible that this is a source of very low levels of glucose found in saliva.

saliva that surrounds it makes it very susceptible to dilution (or contamination if food has been recently consumed). Although it has appeared in investigations at least twice almost twenty years apart¹, it didn't survive as a practical means for measuring glucose either time.

The Retina

If the eye is the window to the soul, might it not also be the best place to find glucose? In addition to the description above of aqueous humor attempts (and below of visual pigment regeneration rates), the optical clarity of the eye has tempted many investigators to seek glucose there, especially in the retina. Attempts to make near- infrared measurements of glucose in the retina have produced universally discouraging results, and attempts to find glucose within the blood vessels visible on the retina have also not yielded success. There are several major complications--there is a limitation to the amount of light that can safely be put into the eye, and only a fraction of one percent of the light is reflected from the retina or its vessels (again, it might be possible to determine *hemoglobin* in retinal blood vessels, but it has the stated huge concentration and color advantage over glucose). Also, there are many interfaces in the eye (both surfaces of the cornea, both surfaces of the lens, and associated membranes) which scatter light, so the light returned from the inside of the eye is difficult to transform into a straightforward measurement.

¹ The first, in 1988, was at the University of Stony Brook in New York; the second, in 2005, was a Professor Yamaguchi at Toyama University in Japan.

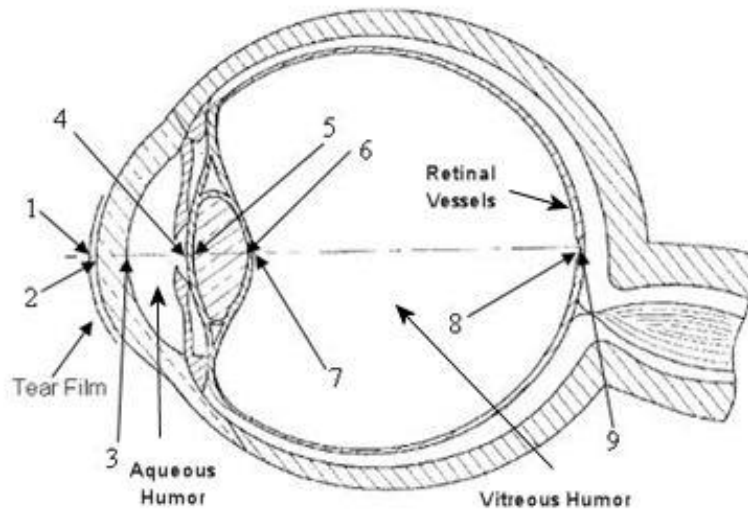

More significantly, in order to make a glucose measurement in retinal vessels (this would almost certainly be a spectroscopic method, and most likely near-infrared), it is necessary to look at the path the measuring light would need to travel and what it holds. The light must pass through several millimeters of the aqueous humor, where the glucose likely varies somewhat more slowly than in blood, and almost 20 millimeters of vitreous humor (the jelly-like fluid inside the eyeball), where glucose is also present but varies much more slowly. The retinal vessels are only a fraction of a millimeter in diameter, so the light would encounter something like one hundred times more glucose in passing through the eye than it would encounter in the retinal vessel. Corrections for this “background” glucose could be made by viewing an area of the retina that has no vessels and subtracting the value obtained, but whenever two large numbers (say 99 and 100) are subtracted from each other, any measurement error is doubled and the result is always much less precise. Retinal arteries, where a pulsatile signal might be seen that could help locate the blood, are smaller and less common than the veins visible on the retina. Finally, the regions of the near-infrared spectrum that are most specific for glucose are wavelengths where the allowed intensity in the eye is severely restricted by safety considerations.

Gluco Vista in Israel tried between about 2006 and 2009 to measure glucose in retinal vessels at the back of the eye.¹ Their website said in 2013 “The Company’s technology was reduced to portable laboratory units that underwent successful clinical tests in 2010 and then was further miniaturized into hand-held units. Advanced clinical studies on the hand-held units will commence shortly at two prominent hospitals in Israel” Two clinical trials are still reported as “ongoing, but not recruiting participants” at clinicaltrials.gov at locations in Israel. It might still be possible to measure glucose in these vessels by focusing the light on the retina (or by using a pulsatile component of the small arteries there), but there has yet been no announcement of success.²

An interesting approach, also sponsored by LifeScan, was investigated by RetiTech. The inventors speculated that, because the human vision processing system is a combination of an older, more primitive motion detection system and a newer system for processing color and fine detail, there could be a difference in perception at different glucose levels. The technique employed computer-generated rotating colored patterns, and seemed to show some differentiation at higher glucose levels, but not with enough resolution for accurate measurements.

A little further afield, but still related to the eye, are techniques that have been patented which make use of vision changes to estimate glucose. After many hours of being bathed in high glucose levels, the lens of the eye swells and changes the focal point of the eye. An early approach used a series of parallel lines with varying separation to estimate the glucose level—the smallest pair that the user could resolve was the approximate glucose level. Others (U.S. Patent 4,750,830—Lee and U.S. Patent 6,442,410—Steffes) have made measurements of the refractive correction of the eye and related that to glucose levels. Unfortunately, this approach again seems to work effectively only at high levels (and after quite a delay), and has not yet been shown to be accurate enough for general use.

¹ U.S. Patent 7,308,293 was filed in 2002 and issued to Jonathan (Yonatan) Gerlitz in 2007. The company was spelled “Glucovista” with no space.

² In about 2008, the same inventor and company began to file patent applications about glucose measurement using mid-infrared emission from tissue (and later patented other technologies)—see that section.

Tears

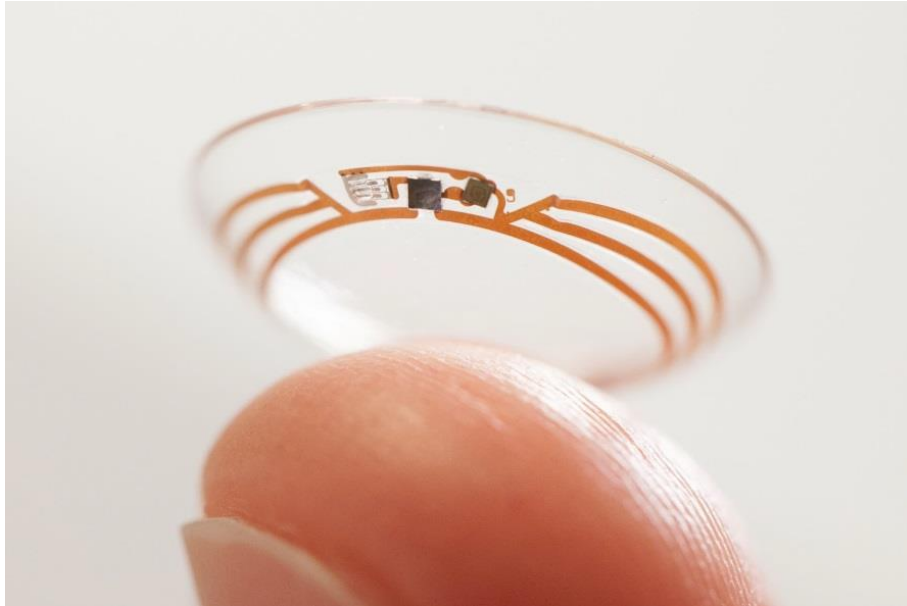

It has often been suggested that contact lenses which change color (or alter their fluorescence) would be an ideal noninvasive monitor. Measurement of glucose in tears has gotten renewed attention with the announcement of Google’s patenting and licensing of a contact lens with electrochemical detection of glucose,¹ and for that reason, this section has been substantially expanded.²

Sources of glucose to a contact lens are aqueous humor (from the inside, through the cornea), tears (from the outside—see below), and the conjunctiva inside the eyelid, but even if suitably nonirritating materials could be found, it is unlikely that they would have either the sensitivity or response time to be suitable for tracking changes in glucose. Because of the intimate contact between a contact lens and other structures on the eye,

¹ Six months after the first announcement, Goggle said that Alcon, a leader in eye care and the second largest division of Novartis, the Swiss pharma giant, would license the Google technology and attempt to bring it to market.

² One of the earliest attempts to make a measurement in tears (for electrolytes, rather than for glucose monitoring), was Orange Medical, a company that existed briefly in Costa Mesa, CA, also producing a traditional strip and meter system (the “Trendstrip” and Trendsometer”). They developed an “ocular ring” in 1988 that could fit inside the eyelids, possibly to make an electrochemical potassium measurement, but it apparently never worked reliably and (before Bluetooth and other near-field communication techniques) suffered the additional visual disadvantage of wires dangling from the eye.

there is a conflict between making the material permeable enough for glucose to diffuse in and react with a sensing compound, and preventing any sensing chemicals from being leached out into the sensitive areas of the cornea or conjunctiva. Both glucose oxidase and a product of its reaction with glucose, hydrogen peroxide, could have irritating or toxic effects on sensitive tissue. Several patents have appeared but no working prototype to date.

A company called Sentek announced in 2001 that it was developing a technology termed “Glucoview” around this approach, and a collaboration between a professor of “bionanotechnology” at the University of Washington and a researcher at Microsoft (that may have later become the Google Verily contact lens—see below) has also been announced. It seems some ideas are just too appealing not to pursue many times, in spite of the Second Law (see below), and a Google search for (“contact lens” glucose) will reveal an amazing number of these attempts.

As Wikipedia stated: “On 16 January 2014 Google announced that, for the past 18 months, they had been working on a contact lens that could help people with diabetes by making it continually check their glucose levels. The idea was originally funded by the National Science Foundation and was first brought to Microsoft. The product was created by Brian Otis and Babak Parviz who were both members of the electrical engineering faculty at the University of Washington prior to working in Google’s secret lab, Google[x]. Google noted in their official announcement that scientists have long looked into how certain body fluids can help track glucose levels easier, but as tears are hard to collect and study, using them was never really an option. They also mentioned that the project is currently being discussed with the FDA, while still noting that there is a lot more work left to do before the product can be released for general usage, which is said to happen in five years at best, and that they are looking for partners who would use the technology for the lens by developing apps that would make the measurements available to the wearers and their respective doctors. The partners would also be expected to use this research and technology to develop advanced medical and vision devices for future generations.”

It was not well communicated amidst the flurry of publicity about the “glucose contact lens,” but the arrangement with Alcon also involved another product, an electronically-controlled autofocus lens. After several years of hype (see the discussion of Gartner’s Hype Cycle in the Preface), and just about a year after Alcon announced that testing of the contact lens would begin “in 2016,” in November of that year, a Reuters dispatch was widely communicated which said: “**Autofocus contact lens being developed by Verily and Alcon suffers delay.**” Almost invisible in the myriad of follow-up news aggregator announcements of this was, as *Stat* [said](#), the contact lens that was the big topic two years earlier: “It’s also unclear when, if ever, human testing might start for a glucose-sensing contact lens meant to relieve diabetics of the need for needle sticks to test their blood sugar. This lens [inspired](#) Google cofounder Sergey Brin to form the ambitious Verily, which, like Google, is a subsidiary of Alphabet.”

Back in 2013, there were at least three announcements of people attempting this technology. Professor Babak Parviz of the University of Washington, with support from MicroSoft, was the first to announce his research efforts for the glucose monitoring lens that later became the Google contact lens, Dr. Jun Hu, associate professor of chemistry at The University of Akron was also trying this approach, using an iPhone to take a picture of a contact lens and determine glucose by color changes in the lens responsive to glucose, and Jeff Walling and Jaesok Jeon of Rutgers University announced they were collaborating on the development of a low power ocular sensor that continually monitors blood glucose levels, using micro-power generated by ascorbic acid and glucose in tears.

Nevertheless, Wei-Chuan Shih, a researcher with the University of Houston, announced in October of 2016 the development of a contact lens using a “surface-enhanced Raman scattering technique” with enough sensitivity to measure the glucose in tears. Not to be outdone, Greg Herman, a professor of chemical engineering at Oregon State University, announced in November of 2016 that his group is using a contact lens sensor with a [nanostructured transistor](#) – specifically an amorphous indium gallium oxide field effect transistor– that can detect subtle glucose changes in physiological buffer solutions, such as the tear fluid in eyes. Philips (WO 2016/150630) and Johnson & Johnson’s Vision Care (US 9,323,073) have also published patents for similar glucose-sensing contact

lenses, and in 2017, and yet another such contact lens was disclosed by Medella Health Inc., of Kitchener, Ontario in patent application US 20170042480.

There are many published technical articles that describe the relationship between glucose in tears and glucose in blood. One of the earliest¹ was Sen and Sarin, *British Journal of Ophthalmology*, 1980, 64, 693-695. The purpose of the study was to see if people could be screened for diabetes by measuring glucose in tears, but the authors concluded “There was no significant correlation between glucose content of blood and tears among normal persons and diabetics.” Another was in 2007, by Baca, et al., *Clinical Chemistry* 53, No. 7, 2007, who used liquid chromatography and mass spectrometry for glucose measurements and made this hopeful observation “We observed significant correlations between fasting blood and tear glucose concentrations ($R = 0.50$, $P = 0.01$).” A correlation coefficient of 0.50, though, yields an R^2 value of 0.25, meaning that there is only about 25% of true correlation, not nearly good enough for glucose monitoring.²

There are also concerns with the rates of tear production and evaporation. Tears are produced unevenly during the day, and the rate of production depends on physical activity and uncommon events, such as emotional responses and yawning. Even though the tear film has a surface coating of an oily layer to reduce evaporation, that rate is influenced by relative humidity and temperature, and by airflow variations from heating, air conditioning, or wind.

Shortly after Google’s announcement, this announcement appeared in 2014: “An award of \$65,000 from Mayo Clinic in Arizona will help Arizona State University bioengineer Jeffrey La Belle³ continue development of a tear-based glucose meter designed to help people living with diabetes monitor their health.”

¹ There were eleven published reports of the measurement of glucose in tears prior to this one, but the methods for glucose measurement were not as accurate, and the concentrations quoted are highly variable.

² One group has determined that a value of R^2 of at least 0.89 is necessary to make a clinically acceptable glucose monitor. This corresponds to $R = 0.94$.

³ The author of a four-part set of articles “A Disposable Tear Glucose Biosensor” in the *Journal of Diabetes Science and Technology* between 2010 and 2014

There has always been some hope that a contact lens, rather than responding to tears, could respond to glucose in the conjunctiva on the inside of the eyelid (which *might* produce a better correlation than tears), but the contact lens is in more intimate and much longer contact with both the tear film between it and the cornea (the cornea does not seem to pass any glucose), and the tear fluid which also surrounds it on the front. Other than during sleep, contact with the conjunctiva is limited to blinks, which last no more than about 150 milliseconds and normally occur about twelve times per minute, for a total contact time of 1.8 seconds per minute, or about 3% of the time.

Attempts to measure glucose in tears have been divided among the use of contact lenses (see sections above), traditional or modified strips and meters, and indwelling devices. As discussed, no contact lens has yet been which shows correlation between glucose in tears and blood, and increasing tear flow to allow use of test strips, either by mechanical or chemical means, has been shown to alter the glucose content from the normal level. Given the delays, a clinically or commercially acceptable contact lens would constitute a great surprise.

A company in the Netherlands called [Noviosense](#) has described a sensor for glucose in tears that resides inside the eyelid. The company lists as one of their advisors [Dr. Joseph Wang](#), whose University of California, San Diego laboratory published an article described elsewhere about a temporary glucose-sensing tattoo (see the section on tattoos).

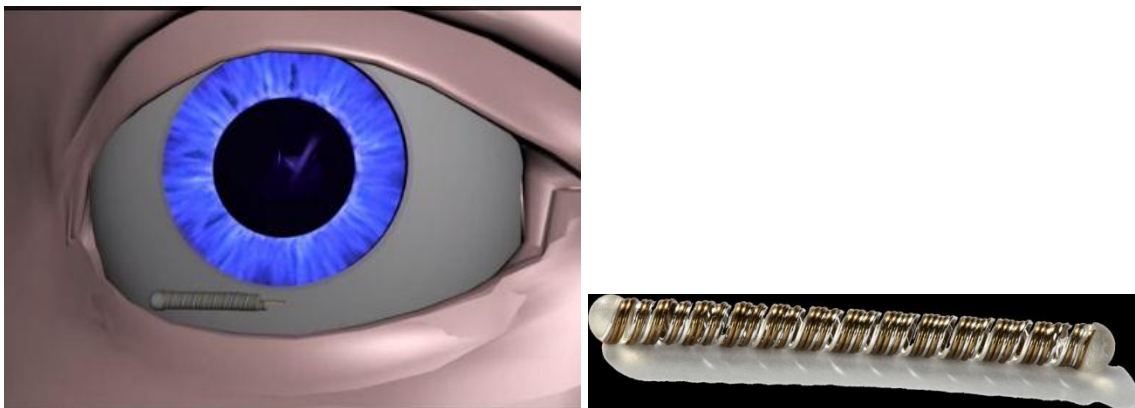

Based on the poor correlations reported in many publications, it is quite unlikely that any device or technique will produce clinically acceptable results for glucose based on measurements in tears, but it seems equally unlikely that people will stop trying to make this measurement.

Saliva

As with tears, attempts continue to be made to measure glucose in saliva. A recent wrinkle for this approach has been the use of “crowdfunding” to finance an effort.

The [iQuickIt](#) Saliva Analyzer was announced on the [Indiegogo website](#), with a goal of raising \$100,000, but the campaign was reported closed on December 18, 2013 with just \$4,230 raised.¹ A much earlier method for glucose in transbuccal fluid (claimed to be different from saliva) was described above, and a second appeared in 1995 under the auspices of Universal Biosensors, at *Biosensors & Bioelectronics* **10** (1995) 379-392.

An article by Siu and others in [Nanophotonics 2014; 3\(3\): 125–140](#), is characteristic of attempts to make this measurement using exotic nanomaterials. It contains many impressive colored graphs describing the proposed detection process, but no results of testing of subjects. A similar report from [Purdue University](#) combines nanostructured sensors with graphene, the latest material touted as the solution to many of the problems of mankind.

Interestingly, a publication by Agrawal ([Noninvasive Method for Glucose Level Estimation by Saliva](#)) in 2013 that studied the correlation between saliva glucose and blood glucose for people with and without diabetes, concluded that the correlation coefficient for people with diabetes (0.40) was so much worse than for those without (0.58) that it could be used as a potential screening method for diabetes, but neither of these values would allow glucose monitoring. Again, regardless of the lack of any evidence for a strong correlation between saliva and blood glucose, it should be anticipated that attempts to find it will continue.

¹ But see the section on impedance measurements for an entirely different crowdfunding experience.

A company from Cliffside Park, NJ (which has appeared with names of [Pop Test](#), Pop Test Cortisol, and Pop Test Oncology) has proposed a system for glucose measurement in saliva which they have proposed for either screening for diabetes or glucose monitoring. They have shown agreement with blood glucose ($R = 0.82$), but this appears to be just for subjects following overnight fasting.

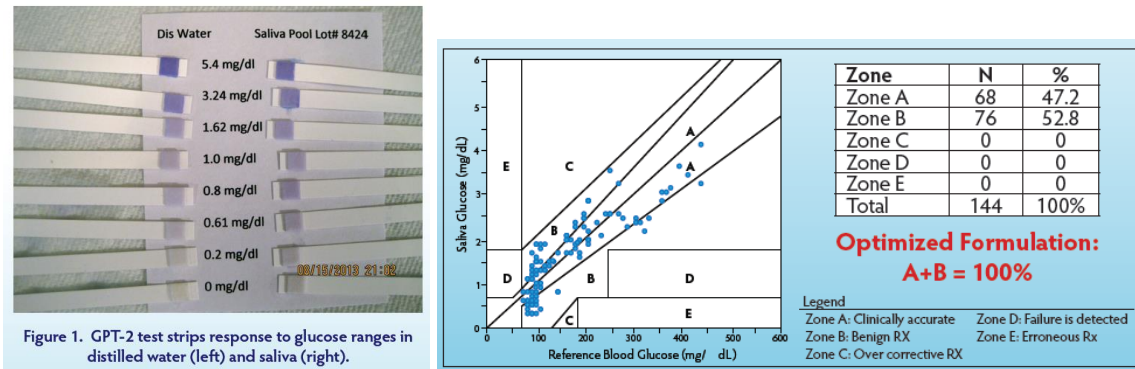

“[Eternity Healthcare](#) announces \$500,000 Regulation ‘S’ Private Placement for Develop a Dual Sensor Noninvasive Saliva-based Sugar Monitor Device to Test for Diabetes”
 “Using two parameters of diabetes physiological changes, the device will provide more accurate results for diabetics and their blood sugar level.” No additional information is available on the device or the parameters, but the company seems heavily focused on investing and stock prices.



Dr. Yan Feng of Hong Kong Polytechnic University has published an [article](#) and has a [news release](#) about a sensor for a saliva glucose test using enzyme-modified graphene.

A company, also in Hong Kong, called [eNano Health](#) has developed the “Kiss and Tell” colorimetric saliva glucose test, but notes on its [website](#) that the device is “No blood. No Pain. No Wound.”, and “Not for diagnostics.”

Breath

Collecting breath is about as noninvasive as a technique could be (and it is known to work well for estimation of blood alcohol), so it has been investigated multiple times to see if something in it corresponds to glucose. It was mentioned above that the exhaled breath of people with severe hyperglycemia often contains acetone—this is the result of the accumulation of compounds, known collectively as “blood ketones” (in early times, “ketone bodies”) that accumulate in the blood with extended hyperglycemia. One of these, called acetoacetate (the other common one is beta-hydroxybutyrate), breaks down to yield acetone in exhaled breath. When the blood glucose concentration is high for extended periods, the compound can even be detected by just smelling the breath, and this has led people to speculate that lower concentrations might be measured and correlated with blood glucose. Similar to urine glucose, however, it has been determined that this is a “threshold” effect that indicates high glucose over time but does not operate reliably at low or even normal glucose levels. Even someone following a low-carbohydrate diet like those called Atkins or South Beach (and thus metabolizing body fat to produce the same ketones in the blood at lower levels) could generate enough acetone to cause errors. So while every year seems to bring another technology devoted to measuring acetone in breath, even if a simple apparatus could be developed, it is probably not a practical system for monitoring glucose levels in blood.

An early patent, US 7,417,730 (now expired due to nonpayment of fees), used an unwieldy “microplasma source” and a spectrometer. A more recent one, WO 2015/200031 A1, is harder to find because “breath” is misspelled “breadth” in the title and many times in the specification. US 9,470,675, assigned to the Council of Scientific & Industrial Research in New Delhi, uses a semiconductor sensor. Another recently-issued patent, US 9,470,675, uses optical detection. Another company, [Applied Nanodetectors, Ltd.](#), of Middlesex, GB, has a sensor for volatile organic compounds in breath, but no device on the market, and a Silicon Valley startup in San Francisco,

Respirix, Inc. has a respiratory monitor application, WO/2016/073945A1, with broader intended applications.

Western New England University's Prof. [Ronny Priefer](#) has founded New England Breath [Technologies](#) to exploit this relationship. His patent application (US20150177224) describes a pair of compounds that react with acetone to develop a substance that absorbs ultraviolet light, which can be measured with a hand-held device,

A company called PositiveID in Del Ray Beach, Florida, started its glucose measurement adventures with a “glucose-sensing RFID microchip” it had acquired, but then changed over to a breath-sensing system based on the “Easy Check” sensor it also acquired, this time from a company in Israel. The device has a patent, US 8848189, a chemical that reacts with acetone to produce a color, but there has been no further information about the appearance of a commercial product, and the company now appears from its [website](#) to be focused on homeland security applications, and as of 2017, there was no longer a mention of noninvasive glucose measurements on the company’s website.

University of California–Irvine scientist [Pietro Galassetti](#) announced a new research program into detection of very trace amounts (parts per trillion) of gases in breath using extremely expensive and complicated equipment. In 2011, he was appointed to the scientific advisory board of PositiveID. Also in 2011, the company acquired MicroFluidic Systems, which does biological testing and sample preparation. In its monthly press release early in 2013, the company described the end of its glucose programs:

“PositiveID Corporation today announced it has entered into an agreement to license its iglucose™ technology to Smart Glucose Meter Corp. ("SGMC") for up to \$2 million based on potential future revenues of glucose test strips sold by SGMC. These revenues will range between \$0.0025 and \$0.005 per strip. A person with diabetes who tests three times per day will use over 1,000 strips per year.

“William J. Caragol, Chairman and CEO of PositiveID, stated, "In 2011, in conjunction with our acquisition of Microfluidic Systems, PositiveID began a corporate realignment to focus on patented molecular diagnostic

technologies for bio-threat detection and rapid medical testing. This was done in order to position the Company to target the current and significant market opportunities in these sectors and take advantage of the detection and cost advantages we believe our technology provides. To date, we have achieved real results as part of this restructuring, including the sale of our implantable microchip IP and related assets, a significant reduction of our cash burn, and now the license of our iglucose wireless diabetes management technology, which we believe is another important milestone in this process."

As of 2017, Dr. Galassetti was no longer listed as a member of the company's Board of Advisors.

Other compounds in exhaled breath have been shown to correlate with blood glucose, and one called "methyl nitrate" was studied extensively in 2007 by B. J. [Novak](#) of UC Irvine. Quantities were again in the parts per trillion range, and measuring it required, however, gas chromatography using electron capture and mass selective detection—equipment too expensive for a hospital, let alone a home, so while this made a great research project, it was not practical as a monitor (besides, there was no attempt to predict glucose values, just to find a correlation—see the Third Law in the following section).

[Philips Company](#) in the Netherlands has a patent application, published in 2009 (US20090270700) which suggested that the carbon monoxide level in breath might correlate with blood glucose, based on the action of an enzyme involved in hemoglobin breakdown called "heme oxygenase." However, a 2008 publication (Fritsch, T., et al., "[Is exhaled carbon monoxide level associated with blood glucose level? A comparison of two breath analyzing methods](#)," J. Biomed. Opt. 13, 034012 (Jun 05, 2008); doi:10.1117/1.2937215) that included two of the inventors on the patent application, stated in its abstract: "The previous finding that the glycemia increase after glucose administration was associated with a significant increase in eCO [exhaled carbon monoxide] concentrations was not confirmed."

A group out of the University of Florida called [Xhale](#) has patented (US 7,914,460 issued to Melker, et al) a method for detecting glucose content in exhaled breath. In their technique, micro-droplets that originate deep in the lungs are collected by condensing the

last part of a patient's breath on a cold surface. Both the amount (the glucose concentration is reduced by a factor of 1,000 to 1,000,000 in these droplets) and concentration of glucose in this condensate will vary over time, so the technique requires measurement of another (relatively nonvarying) compound originating in blood (such as chloride ion) and establishing a ratio of the two in the condensate. Unfortunately, this requires the measurement of a ratio of exceptionally small amounts of two compounds, which would be expected to add to the error of the overall measurement. The company has since closed down.

Breath—A Cautionary Tale. The Internet-sourced story below is an example of the thought process that has gone through the minds of many people who have an interest in this field. It is presented without comment.

“The idea came to me one day when I took my car in for its biennial smog test. An internal combustion engine takes in air (containing oxygen and some other gases), combines it with fuel (generally gasoline), causes oxidation to occur (it happens quickly enough that we perceive it as an explosion), converts some of the heat produced into mechanical energy, and blows the products (heat, carbon dioxide, water, and a bunch of other stuff) out the tailpipe.

The human body is a chemical engine that operates in much the same way. We take in air (containing oxygen and some other gases), combine it with fuel (food that is turned into glucose), cause oxidation to occur (relatively slowly), convert the energy into mechanical and chemical energy, and get rid of the waste products through several means, one of which is by exhaling.

By measuring the products that come out when you exhale, it should be possible to get a very good idea of what is going on inside the engine (your body).

Your first thought might be, “This is a waste of time, glucose is not a blood gas.”

While glucose is not a blood gas, neither is alcohol, and it is certainly possible to measure blood alcohol levels from breath analysis.

Here are some possibilities:

Look for something already in exhaled breath.

It might be a single substance. It might be a combination of substances or the ratio between two or more substances.

It might require that the user take a calibrated inhaled breath. That's ok, we can have the user inhale through our device and measure the air being inhaled.

We can add something to the breath being inhaled. However, it has to be something that is completely innocuous and also extremely cheap. Anything radioactive is completely out. Maybe some form of a nitrogen gas compound. Or maybe a form of an oxygen gas compound. Maybe a non-radioactive isotope of oxygen. ("Read your glucose level and get a boost at the same time.") Hopefully, it won't be helium.

If we are really lucky it could require eating something that looks like a small piece of candy that tastes like chocolate."

Voice

An international patent application has appeared (WO2014/072823) where the Russian inventors would like to correlate changes in voice with glucose levels:

"As applied to the present application, [] the biological tissue of the larynx and the cord, whose elasticity ratio is suffering change under the impact of changes in glucose level in the human blood. Therefore, it would be interesting to use the identified correlation between changes in the sound fluctuation spectrum of the voice of a person and changes in his/her blood biochemical parameters." Once again, we will await correlation studies.

Hypoglycemia Monitors

With the many failures of noninvasive glucose monitoring in mind, some groups have set their sights a little lower and tried to produce a device that detects only low glucose values to set off an alarm. Hypoglycemia creates a spectrum of symptoms (although not all people display all the symptoms, and people who have had diabetes for many years sometimes become insensitive to hypoglycemia), including sweating, nervousness, tremor, hunger, confusion, difficulty reading or speaking, and eventually, unconsciousness. Because confusion and other symptoms are common (and because many hypoglycemic events occur during the night), it's difficult to detect low values with

a traditional blood glucose meter. Various devices have been proposed over the years to detect these symptoms (although relatively few actually try to measure glucose, which becomes increasingly difficult at lower values), and the continuous glucose monitors now on the market are possibly the best method of detecting low values, especially at night.

Devices on the market rely primarily on skin temperature and perspiration (devices that sense these parameters have been marketed since the late 1980s) and range from a pair of wristwatch-sized ones called HAS-01 from Medpage in the U.K. (for nighttime use, with a “sale price” of \$123.16; it seems to have disappeared), to a device called “Hypomon” marketed by Aimedics¹ in Australia that is a combination of a belt and monitor for people with type 1 diabetes aged 10-25. It sells for \$1500. On 5 August 2013, however, TGA [Australia’s Therapeutic Goods Administration] identified that HypoMon was not performing as well as expected. The rate of detection of sleep-time hypoglycemic episodes was lower than the rate specified in HypoMon's Instructions for Use (IFU), and all the devices were recalled from the market. In 2017, the company no longer had a website.



The [Diabetes Sentry](#) (\$495) by a company of the same name, was given FDA clearance before 2005, has issued U.S. Patent 7,052,472, and according to the website, monitors both increases in perspiration and decreases in skin temperature, both known symptoms

¹ Skladnev. V., et al., [Clinical Evaluation of a Noninvasive Alarm System for Nocturnal Hypoglycemia](#), Journal of Diabetes Science and Technology, Volume 4, Issue 1, January 2010

of a hypoglycemic event. They say it is “The only FDA approved, patented, wearable, non-invasive, sensor based Hypoglycemia symptom alarm available on the market.”



A new entrant into this field is Nightsense with their Hypo-Sense, an Israeli company that appears to be successor to Bio-Impedance General. They say they are in “the very early stages” of developing such a device, and their [clinical trial](#) is listed as “This study has been completed.” A [video](#) on Vimeo concludes with “Register today at: www.nightsense.com,” but that website is now directed to very different activities.

A system was being developed by Cybiocare in Quebec, described as a simple arm band that claimed to be a noninvasive “photonic” glucose monitor based on near-infrared light. It required entry of blood glucose results from another device, but only provided an alarm if the instrument “sensed” the onset of a hypoglycemic event. In 2017, only an [archive](#) remains. A product using similar promotional pictures, also named PGS, appeared on a website for a company called Onsens, but like Cybiocare, that website is also gone.

Tying Ideas to New Technologies

FreeStyle Tracker. It’s easier to gain attention, press coverage or possibly funding when a proposed glucose monitoring technology is tied to the latest consumer electronic technology. TheraSense (now part of Abbott Diabetes Care) was the first company to connect a blood glucose meter to a hand-held “Personal Digital Assistant” (PDA), the FreeStyle “Tracker” that used a Handspring Visor PDA.



The product was launched in 2002, just a year before Handspring was merged into Palm, the other leading maker of PDAs, resulting in the discontinuation of the Handspring Visor. Recent reports have circulated about a system using a fluorescent nanoparticle tattoo, developed by a team at Northeastern University, that could be read using an iPhone application as the detector, and announcements are frequently made of devices that incorporate Bluetooth communications¹ or Radio Frequency Identification Devices (RFIDs).

iBGStar—Possibly the starkest example of this hazard was a meter called the [iBGStar](#) that attached to Apple’s wildly popular iPhone, developed by AgaMatrix and marketed by Sanofi as that French company’s first involvement with blood glucose monitoring. The product had no sooner launched than Apple made a revision to the iPhone’s operating system that made it inoperable. Shortly later, Apple changed the connector from a 30-pin to the “Lightning” connector of the iPhone 5, and an external adaptor was required to use the two together. Consumer electronics, which have relatively limited regulatory hurdles, progress much more quickly than medical devices with their sometimes cumbersome approval processes, and most such combinations are challenged

¹ Medtronic, the leading insulin pump producer, announced in 2011 that they had teamed up with Ford to develop a prototype system that adds a Bluetooth link for their continuous blood glucose monitoring system, allowing audio alerts and visual displays about glucose levels while driving. Almost nothing has been heard since the original splash.

at least as much by obsolescence of the coupled electronic device as by limitations of the glucose measurement technology.¹



In September of 2013, the U.S. Food and Drug Administration announced it will focus its oversight on apps that turn a phone or tablet into a medical device that is already under government regulation, such as one that measures the amount of glucose in a person's blood or controls the inflation of a blood pressure cuff. If an app like this doesn't work properly, the FDA says, it could result in the wrong diagnosis or treatment and threaten a patient's health. It was feared this could mean more regulatory hurdles for makers of these glucose devices and “apps.”

But in January of 2015, The U.S. Food and Drug Administration allowed marketing of the first set of mobile medical apps, the Dexcom Share, which allowed people with diabetes to automatically and securely share data from a continuous glucose monitor (CGM) with other people in real-time using an Apple mobile device such as an iPhone. FDA reviewed data for the Dexcom Share system through the *de novo* classification process, a regulatory pathway for low- to moderate-risk medical devices that are novel and not substantially equivalent to any legally marketed device, and said that data provided by Dexcom showed the device functioned as intended and transmitted data accurately and securely. This put to rest fears that FDA might require clearance under more stringent 510(k) notifications for devices that receive data but do not make the

¹ LifeScan engineers worked to integrate a One Touch glucose meter into Apple's “Newton” PDA. Fortunately, the project was still in the conceptual stage when Newton was withdrawn from the market.

measurements. Many other such linked devices and “apps” have since been cleared for use in glucose monitoring and diabetes management.

Others

Other approaches which are less widely investigated (and some of which are truly unique), will be described in the sections below.

Evaluation Techniques

Why Does It Keep Going On?

One of the disturbing questions about this field is this: Since well over a hundred of these approaches have failed, why on earth would people invest money in the next one?

Venture capital investors, who fund the majority of these approaches, generally look at three things when deciding whether to invest—the “pedigree” of the scientific and management team, the technology, and the market opportunity. About the last, there has never been a question—blood glucose monitoring is, as of 2017, still over a \$10 billion worldwide market, and even though the chances for substantial expansion (as a dollar market) were decreased with the decreased reimbursement for test strips in July of 2013, a noninvasive monitor would still represent the “Holy Grail” of medical device venture capital market opportunities.

The quality of the management team is much harder to assess. Many of the people who set out to do this have a good scientific background (with a few spectacular exceptions that we’ll note later) but many experience something akin to a religious vision when a great idea reveals itself to them, wind up possessed by an almost messianic zeal to see their dream realized, and the pursuit takes on overtones of a “quest.” If a company’s management is populated by those who have succeeded, either with medical devices or in a diabetes-related business, the team is much more highly regarded.¹

It’s not hard to understand the multiple driving forces that make inventors into “true believers:” the chance to help millions of people afflicted by a life-threatening, incurable disease; the chance for scientific recognition in succeeding where so many have failed; and, undeniably, the chance to become very wealthy as the result of those efforts. These have combined to cloud the otherwise sound judgment of many respected investigators

¹ I joined Fovioptics in 2004 when their attempts to raise funding were not succeeding. Based at least in part on my participation, we obtained about \$4M in initial Venture capital funding. When the company hired an executive from TheraSense (which made blood glucose monitors and had just been sold to Abbott for \$1.2 billion) as CEO and the previous CEO of TheraSense as Chairman, the next round of funding brought \$18M, with “term sheets” from four venture capital funds.

(and possibly only one of these factors might suffice to accentuate tendencies of the less altruistic). While “angel” investors, often close friends or family of a company founder may invest in early rounds out of friendship or loyalty, venture capitalists are viewed as quick-thinking, steely-eyed judges of people, but they’re human, too, and can be swayed by people who really believe in what they’re peddling.

The really challenging issue is assessment of the technology. The straightforward, easily-explained approaches have long since been tried, and as the ideas get more exotic or more scientifically complicated, they become increasingly hard for nonscientists to understand. Worse yet, the failures are rarely publicized by those who have failed, and the same technology can be described by different people using slightly different terminology and sound like an entirely different approach. Because very few investors are trained scientists, almost none would be expected to have sufficient breadth of experience to objectively evaluate the exceptional range of technical approaches that have been proposed.¹ As a result, they rely on consultants with expertise in the primary area of technology for any proposal, and few such consultants are familiar with all the special quirks of glucose measurement in tissue described here.

Yet another consideration is that, once intrigued by this pursuit, investigators may switch from one technique that did not work to another approach that appears promising.² There are at least a half-dozen examples detailed here where the same person has pursued different—often dramatically different—technologies for glucose measurement. Sometimes too, investigators will attract a second investor (or employer) after an initial one has lost interest. An example is two inventors, Yoon Ok Kim and Ok-Kyung Cho, who were intriguing because they had addresses in Germany, but were funded by Hitachi, and involved a number of independent technologies to arrive at a glucose measurement, such as temperature, optical spectra, and skin conductivity (see the “Combination of Ingredients” section below). They were issued eleven U.S. patents with filing dates of

¹ It seems especially attractive if inventors include the most recent exotic device in their technology. It is possible, for example, that employing a “quantum cascade laser” instead of a simple LED or laser diode will enhance a new technology in the eyes of potential investors.

2003 and 2004 that were assigned to Hitachi (occasionally with co-inventors having addresses in Japan), but beginning with a filing date in 2006, at least four U.S. patents involving glucose have issued to them that were assigned to Ingo Flore in Dortmund, Germany. Dr. Ingo Flore appears to be an attorney who has no other U.S. patents related to glucose.

Occasionally, this “switch” has been the result of venture investments not fully spent during one stint; in other cases because the researcher had developed a reputation in the field which allowed additional investments or grant approvals in new areas, and a few individuals have even made it their life’s purpose to solve this problem and will gravitate to the next new promising approach wherever it appears.

AstraZeneca, a British pharma company, posted a challenge in late 2014: “AstraZeneca Challenge: Developing a Minimally Invasive Glucose Monitor,” announced on the “crowd-solving” website <https://www.innocentive.com/ar/challenge/9933680>. “This is an electronic Request-for-Partners (eRFP) Challenge. The Solver will write a preliminary proposal (including supporting non-confidential information and contact details) to be evaluated by the Seeker with a goal of establishing a collaborative partnership. Upon completion of the evaluation, AstraZeneca may contact selected Solvers directly to work out terms for a collaboration contract. The monetary value of the contract will vary depending on the amount of work to be delivered and the agreed upon time frame.” Many entries were undoubtedly submitted, but no winner was declared publicly; some entrants were eventually advised that they had not been selected as winners.

A subsequent challenge “AstraZeneca Challenge: Robust Online In Vivo Measurement of Biomarker Concentrations” with a \$25,000 prize was announced in March, 2016.

What Makes Everyone Think Their Approach Works?

Richard Feynman, the irascible physicist and Nobel laureate from Cal Tech, provided the guidance: “The first principle is that you must not fool yourself, and you are the easiest

person to fool.” There are two sets of reasons that people believe too much—the first is scientific, and the second is more associated with personality and faith. First, here are some of the reasons that science can lead an investigator astray.

Oral Glucose Tolerance Tests

When a person has fully developed type 1 or type 2 diabetes, the symptoms are hard to miss: excessive thirst and urination, even acetone in the breath. In the early stages, especially in type 2 diabetes, the onset is a gradual process that is very hard to sense or measure. There are two tests¹ widely used to diagnose diabetes: fasting plasma glucose (FPG) and the oral glucose tolerance test (OGTT).² When a patient’s blood glucose (it’s called “plasma glucose” when measured in a laboratory) is over 126 mg/dl before eating in the morning on two occasions, the patient is presumed to have diabetes. The alternative (or confirming) OGTT is one where the patient consumes 50 to 100 grams of glucose in a fruit or cola-flavored beverage, and blood glucose values are measured over the next several hours.

¹ Glycosylated hemoglobin percentage, or “A1c,” has also been recommended as a diagnostic test for diabetes.

² A recent addition to the available screening tests, named the “Scout,” was developed by VeraLight, a spinoff of InLight Solutions in Albuquerque, NM. Their testing system combines a measure of the degree of crosslinking of proteins in the skin using visible light fluorescence with near-infrared spectroscopy, and produces a “diabetes risk score.” It is a noninvasive test and has been approved for use in Canada and Europe, but the company was a casualty of the funding drought and was sold off to Miraculins, Inc. in Winnipeg, Manitoba.

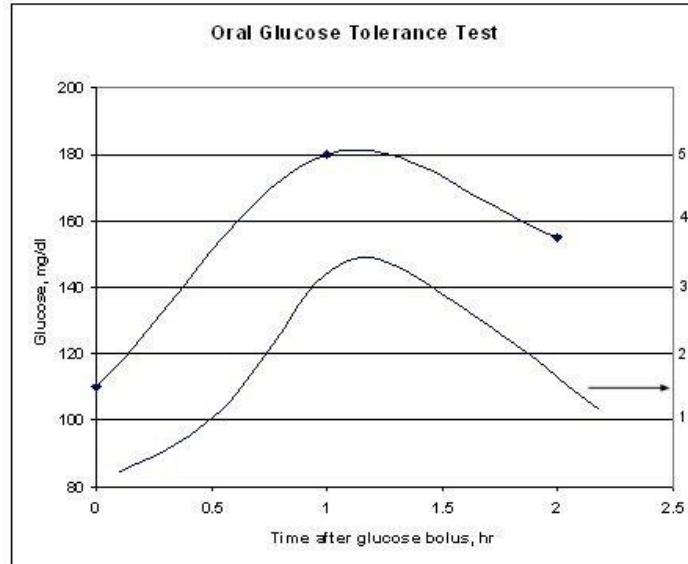

For a nonpregnant person (stated this way because the test is frequently used to test for gestational diabetes in pregnant women, and the diagnostic values are different), the values for people without diabetes should be as follows: fasting, 110 mg/dl or less; at one hour after drinking a beverage containing 75 grams of glucose, the value should be 180 mg/dl or less, and at two hours, 155 mg/dl or less (upper curve in the graph above). The OGTT is a relatively simple test, requires only a blood glucose meter and an easily-obtained liquid (two cans of soda would contain about the same amount of sugar, but much of that sugar is fructose, which makes soda completely unsuitable for testing with meters and strips that are specific for glucose), so it can be readily performed by an investigator to cause a significant change in his blood glucose as a “quick and dirty” test to see if a noninvasive monitoring technology shows promise.

Physiologically, when a person ingests 50 to 100 grams of glucose in a single drink, it creates a massive disruption of metabolism (as well as of the entire endocrine system), and this effect is intended when trying to determine how well the metabolic system handles large amounts of glucose for a diagnosis of diabetes. However, when the intent is to determine whether another parameter is also a good measure of glucose concentration, the results have often been disastrous! This leads to the First Law of noninvasive glucose:

First Law:

Almost every measured physiological parameter will show strong correlation with the curve in an oral glucose tolerance test.

This single, little-appreciated law has by itself resulted in the inappropriate spending of *hundreds of millions* of invested dollars in the area of noninvasive glucose research! Examples of parameters which show good correlation with the curve in an OGTT are core and surface temperature, peripheral perfusion, skin hydration, electrolyte balance, gastric motility, peripheral edema, enzyme levels (liver, heart, brain and digestive), galvanic skin response, respiration, urine production, saliva production and many others. In short, any function related to metabolism or the overall endocrine system is more likely to show correlation than not.

Correlation

The statistical techniques referred to below generally operate on the assumption that all the error in the measurement is from the device, and that none is from the reference measurement. In fact, there often is error in the reference measurement, and this further complicates the analysis. Many such tests are done using a traditional glucose meter and strips, with interferences from drugs and components of blood that may not be well understood by the investigators. The “gold standard” reference method of the industry is a series of instruments produced by [Yellow Springs Instruments](#) (YSI Inc. in Yellow Springs, Ohio), collectively known as “the YSI.” Based on an electrochemical technique pioneered by Dr. Leland Clark in the early 1970s, the reasonably-priced lab instruments made by YSI are respected for their accuracy, their freedom from chemical interferences in blood, and their reliability when properly maintained. Unless a comparative study of the differences between two devices is being performed, investigators are always encouraged to make reference measurements with the YSI.¹

¹ This issue is also important when considering calibration of a proposed noninvasive meter. If the device needs to be calibrated frequently, the only way patients can do so is to obtain a glucose value with their “finger stick” meter and enter it into the noninvasive device. In addition to the potential errors from drugs,

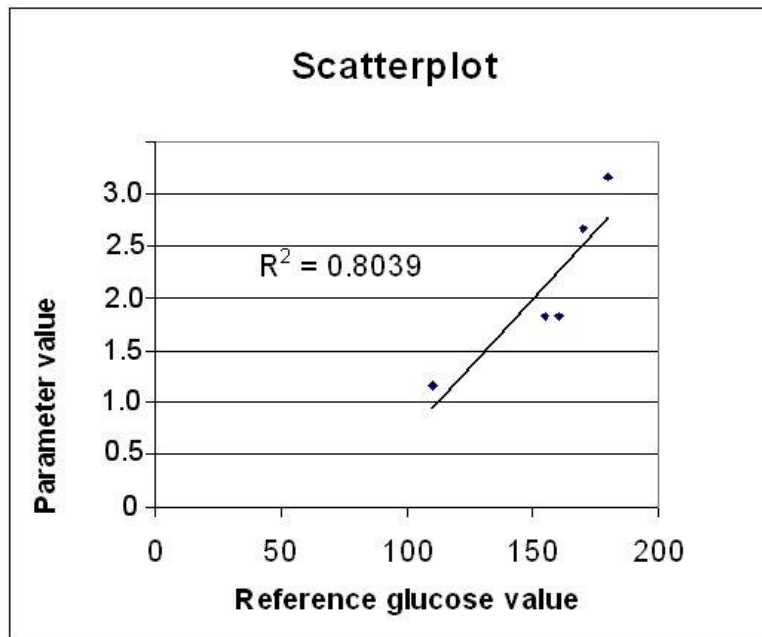

To see if there is a relationship between the effect being studied and a variation in glucose, the two results are plotted against each other in what's termed a correlation plot or more commonly, a "scatterplot." A calculation of the best straight line among the points ("linear regression," sometimes called a "linear trendline") shows how well they line up with each other, and a "correlation coefficient" R (technically called Pearson's Product Moment Correlation) that expresses the degree of agreement between the points is also calculated. When that value is squared (R^2), it is a quantitative measure of the agreement between the experimental and reference measurements (If $R^2 = 1.0$, there is perfect agreement, and if $R^2 = 0$, there is no agreement whatsoever, and an R^2 of 0.5 means that there is 50% of an actual correlation, while the rest of the results are random association). The one great flaw of this type of analysis is that the mathematics it uses place more emphasis on the results with the largest numerical value, and more than one experimenter has taken advantage of this by finding a few well-agreeing points at the

hemoglobin and oxygen saturation that affect many meters, there is also a possibility that the glucose level measured in blood from the fingertip may not correlate well with the glucose in interstitial fluid that is sensed in tissue by many proposed noninvasive meters. This effect can be exacerbated by testing after meals and could lead to a serious calibration error. However, no noninvasive meter has yet progressed to the point where this has become a significant problem.

extreme right-hand side of the graph, using them to overwhelm the numbers from a passel of mediocre agreements on the left hand side, where the need for accuracy is actually much more critical.

Another metric that has come into greater use is known as MARD, or mean absolute relative difference—it gives the average percentage difference between measurements (ignoring whether they are higher or lower) made with the experimental device and the reference measurement. It is generally a better estimate of system accuracy than the median absolute relative difference (MDARD) statistic, which is sometimes quoted. Estimates of MARD values for strip-and-meter systems are between 5 and 10%, and a value of 15% would be considered very good for a noninvasive system. Recent published results for CGM systems are less than 10%, but those systems do a good deal of smoothing and projection of results to achieve performance at that level.

An entertaining example of this kind of agreement appeared briefly on the website of a hopeful provider of a new noninvasive technology. Clearly, one of the lines was intended to be “*in-vivo*” (measurement within a living being) and the other “*in-vitro*” (measurement made “in glass” using fluid extracted from the body, *i.e.*, a reference blood glucose measurement). It is possible to conjecture that the plot was made under the hopeful influence of too much wine (the website was later corrected).

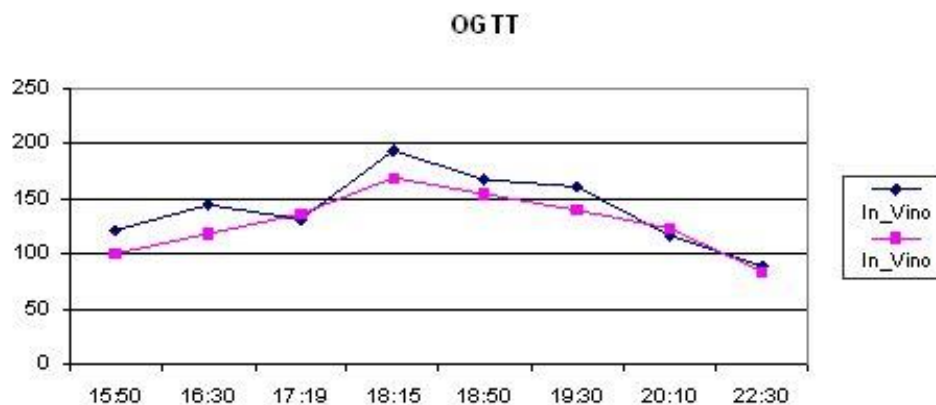

Generally speaking, an R^2 value of 0.9 for a noninvasive test (compared to a good reference, such as the YSI) would be considered acceptable to bring a device to market, with 0.85 being about the lowest value that should be interpreted as showing promise. Of

course, many of these studies are performed by trained laboratory personnel, not by patients with diabetes, and equivalently good results are rarely found with in-home testing. Worse yet, a correlation obtained in the lab with an early prototype may be compromised as the realities of product development require size and cost reduction from the lab unit, and what seemed promising on the benchtop often falls apart when a more practical commercial device is developed.

Clarke Error Grid

Because diabetes places individuals at different levels of risk depending on the level and duration of glucose values (low levels for any length of time are “acutely” dangerous, while high levels have more of a “chronic” impact over days or years), different levels of hazard are assigned to errors of different kinds, and simple correlation doesn’t tell the whole story. One common way of expressing this is the use of an “error grid” published by W.L. Clarke, et al. in 1987, and known universally in the industry as the “Clarke Error Grid.” It has been widely adopted for use in the evaluation of blood glucose monitoring systems (a revised and more detailed version, called the “Consensus Error Grid, is described below, and is being gradually more widely adopted).

The grid plot divides up the possible errors into groups. For instance, if the patient’s blood glucose is low, and the device being used to test says that it’s high, the patient might take more insulin, lose consciousness, and place his life in jeopardy. On the other hand, if the true glucose value is high, and the device reads low, the patient might eat some food or drink orange juice, but it’s not likely that immediate harm will result. The grid looks like this:

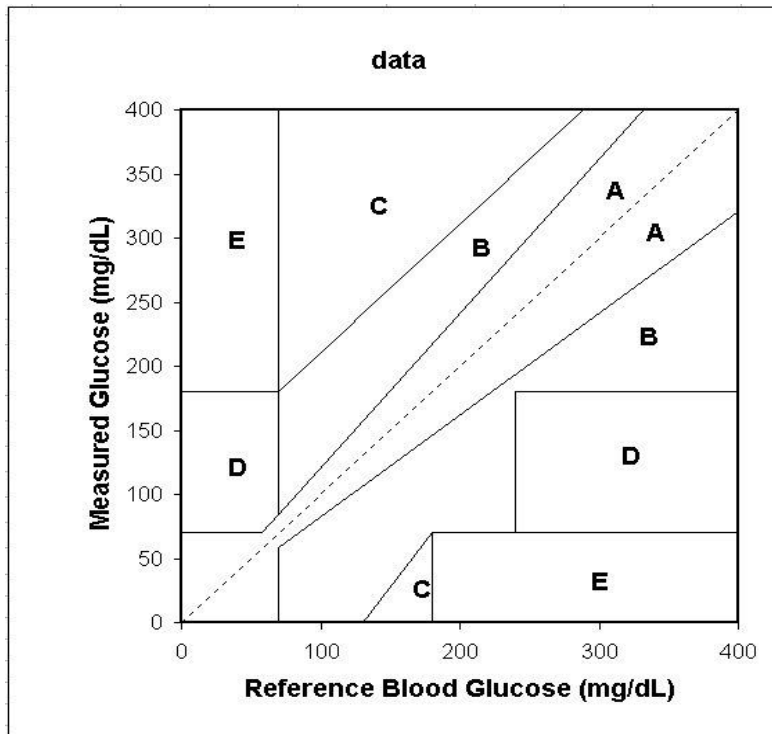

Error grid region definitions:

- A: "Clinically Accurate"**
- B: "Benign Errors, Clinically Acceptable"**
- C: "OverCorrection"**
- D: "Dangerous Failure to Detect and Treat"**
- E: "Erroneous Treatment, Serious Errors"**

**Source: FDA Clinical Chemistry and Clinical Toxicology
Devices Panel Meeting Dec 6, 1999**

The regions of the chart have been designated as shown, with mnemonics to help recall how the regions should be interpreted. As valuable as this presentation is, it can make data that are truly not very good seem acceptable and vice versa. The goal of a traditional meter would be to have 98% of the values in the A and B regions, with less than 0.1% (one in one thousand measurements) in E. For noninvasive devices, no generally accepted standards exist, and each group tries to define what they think will be found “acceptable” by the FDA.

There are frequent publications of poor correlations that can look promising on a Clarke Error Grid. Many of these have been described as “double barrel” results, looking more like the pattern from a pair of shotgun blasts. Red flags on this sort of data presentation are: limited glucose range (almost all points between 70 and 150 mg/dl), and generally poor correlation.

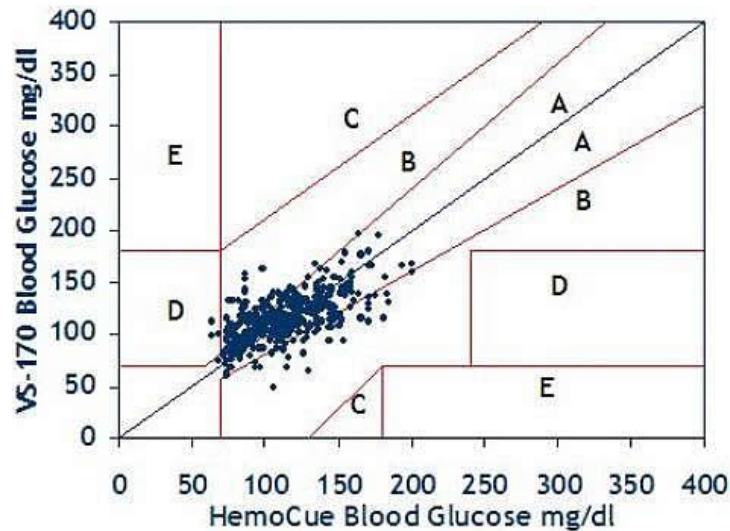

The collection of results shown below is an example of the optimistic slant that an error grid plot can place on a data set. While over 97% of the results are in the A and B region, the overall correlation as measured by R^2 is only 0.66 (and the mean absolute relative difference (MARD), shown here as “MAE” is 20%)—a device with this correlation would likely not be acceptable for home use by patients.

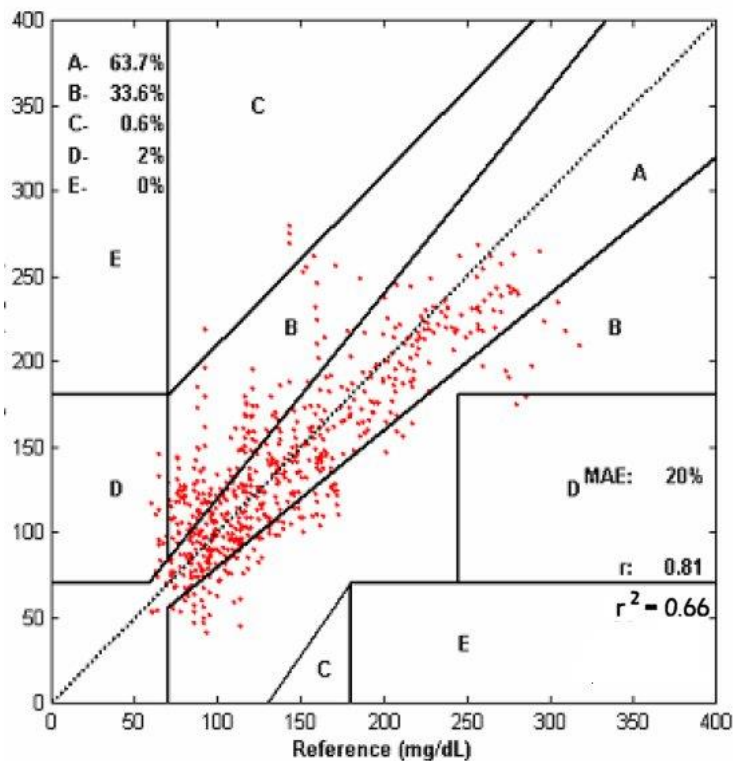

ISO Standards

In 2003 the International Organization for Standardization (ISO) published standard 15197, specifying the required accuracy for blood glucose meters. It required that 95% of all results above 75 mg/dl fall within 20% of the reference value, and that 95% of all results equal to or below 75 mg/dl fall within 15 mg/dl of the reference value. A revision published in 2013 (with a 36-month transition period) will require 95% of all results above 100 mg/dl to fall within 15% of the reference value, and 95% of all results equal to or below 100 mg/dl to fall within 15 mg/dl of the reference value. It will also require that 99% of the results fall within the A and B zones of the “Consensus Error Grid” (see below), and will require testing with three lots of reagents instead of one.

Consensus Error Grid

A revision to the Clarke Error Grid above was published in 2000 by Parkes, et al.¹, and is known as either the “Consensus Error Grid or the “Parkes Error Grid.” An image of that grid is below, followed by the letter ranges (but the “A” zone of the Consensus Error Grid is not the same as the new set of requirements imposed by the ISO standard).

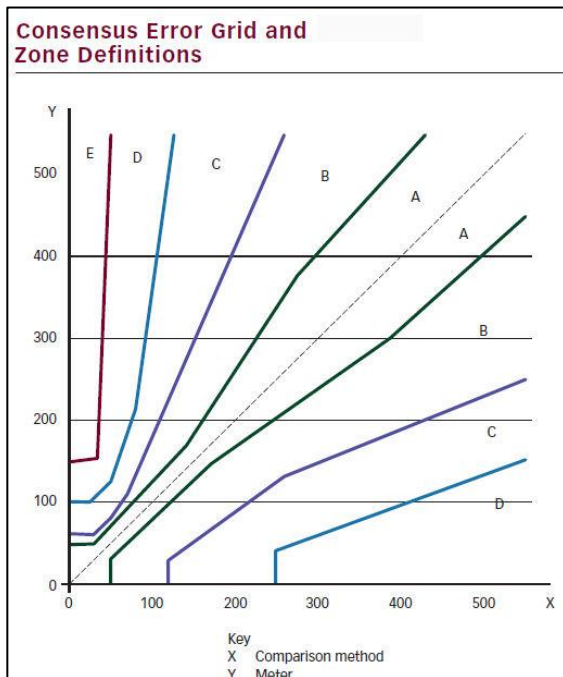

Risk Level (CEG zone)	Risk to Patient with Diabetes
A	No effect on clinical action
B	Altered clinical action – little or no effect on clinical outcome
C	Altered clinical action – likely to affect clinical outcome
D	Altered clinical action – could have significant medical risk
E	Altered clinical action – could have dangerous consequences

The five zones (A, B, C, D, and E) of the Consensus Error Grid (CEG) are defined by estimated patient risk. ©International Organization for Standardization (ISO) 2013 – all rights reserved. This figure is reproduced from ISO/Final Draft International Standard (FDIS) 15197 with permission of American National Standards Institute (ANSI) on behalf of ISO. This is a draft ISO document that is subject to change without notice and cannot be referred to or relied upon as an ISO standard.

Specificity

Two fundamental issues have plagued those making measurements since analysis began: sensitivity and specificity; they are both of great importance in any attempt to measure glucose in tissue.

The issue of sensitivity is well known and fully described under many of the measurement techniques that follow—there is very little glucose present, and to most measurements, it does not present a strong signal, both of which make it hard to measure. The problem of specificity is more subtle, and requires more in-depth knowledge of how a measurement of a physical parameter can be related to glucose concentration. Many measurement techniques (for example refractive index, with the corollary of light

¹ Diabetes Care, Volume 23, Number 8, August, 2000 p. 1143

scattering, optical coherence tomography, radio-frequency or microwave impedance measurements) will show a good, short-term correlation with blood glucose variations, and this has led many groups (see the section on Radio Frequency/Impedance for examples) to believe that their technique responds specifically to glucose, when in fact just the opposite is true.

The examples of measurement techniques above, along with others, respond to what are known as “bulk properties” of tissue fluids, known to scientists as “colligative properties:” those that respond to the total number of components in solution. Density, refractive index, osmotic pressure, freezing point depression or boiling point elevation are all parameters that respond only to the total number of particles in solution, and do not differentiate among those particles. As such, they will respond to changes in any of the materials dissolved in the fluids of tissue with the same sensitivity that they respond to changes in glucose.

In addition to their effect of directly varying glucose concentration in body fluids, variations in glucose concentration have an insidious effect that impacts these measurements—it shifts the amount of water in various “fluid compartments” of the body. Water exists in, and moves among, intracellular fluid (within the cell), interstitial fluid, and plasma (“intravascular fluid”), where the last two combine as “extracellular fluids.” Because the concentration of glucose varies by more than most other substances, a change in its concentration alters the composition of these fluids, and the body responds by shifting the amount of water to regain balance.

Near-infrared absorbance measurements (see that section), where water absorbs strongly and can be measured more or less directly, have gradually learned at great expense that the majority of the signal seen there is due to variations in the amount of water present in interstitial fluid. Unfortunately, other impacts on the body also influence this “water balance”—exercise, hydration, nutrition, electrolyte levels, even monthly cycles in women. These also influence the distribution of water between the compartments, and the tenuous correlation that exists between measurements that respond to the distribution of

water (and that can *appear* to respond to glucose concentration) falls apart, often in less than 24 hours.

An example that will be detailed more fully below is impedance measurements. While it is known that impedance measurements respond to these bulk properties (or even to the variations that result from their influence on the distribution of water), in spite of more than a dozen failed attempts to correlate these measurements with glucose, no specific interaction between the glucose molecule and electromagnetic energy in the radio-frequency (or microwave) regions has ever been proven—many frequencies will show a variation in response as glucose levels in tissue are varied, but no frequency or range has ever been shown to give a specific response to the glucose molecule, and correlations based this relationship will not hold up over time.

A series of comprehensive reviews^{1,2,3} (available from a Google search for the titles) detail the degree of interaction between electromagnetic radiation and tissue over a wide frequency range. The actual technology of interaction between tissue and radiation is complex and difficult to understand, but it is nonspecific, and no publication has yet reported a specific frequency or group of frequencies that accurately respond to glucose concentration.

Emotional Considerations

Following the earlier heading “What Makes Everyone Think Their Approach Works?”, the second set of considerations is decidedly nonscientific. As mentioned, diabetes touches every family and none more intimately than when someone’s small child is diagnosed with diabetes. If the parent is a scientist or engineer, or has a close friend who is one, an incredibly strong driving force can develop to find a way to measure the child’s glucose without sticking a needle in his/her finger. When emotion supplements reason (or worse, supplants it), it’s very easy for an otherwise rigorous investigator to begin to

¹ C Gabriel, S Gabriel and E Corthout, The dielectric properties of biological tissues: I. Literature survey, *Phys. Med. Biol.* **41** (1996) 2231–2249.

² S Gabriel, R W Lau and C Gabriel, The dielectric properties of biological tissues: II. Measurements in the frequency range 10 Hz to 20 GHz, *Phys. Med. Biol.* **41** (1996) 2251–2269

³ S Gabriel, R W Lau and C Gabriel, The dielectric properties of biological tissues: III. Parametric models for the dielectric spectrum of tissues, *Phys. Med. Biol.* **41** (1996) 2271–2293.

believe in the faintest of correlations. Even those who have not been personally affected by the disease could recognize the tremendous benefit that would accrue to millions of people with diabetes if a truly noninvasive monitoring technique could be developed. This has led to a group of researchers, who can only be described as “true believers,” who have abandoned their skepticism in favor of a certainty that the method they are pursuing is right, and usually, the only right way. When this happens, they will argue with anyone who does not see the correlation of data the way they do, or who cannot see the bright, clear path to success that has been revealed to them.¹ Most often, the people who keep trying against all reason are determined, well-intentioned souls who don’t realize what they’re up against in trying to solve this problem, or simply can’t acknowledge that they have not succeeded.

Consider the following excerpt from an article in *Diabetes Interview Magazine* of April, 2004 (names have been deleted): “Company president __, formerly a physicist in the semi-conductor industry, wants a piece of the noninvasive pie, but his motivation is much more personal: his son, __, developed diabetes more than a decade ago. This led __ to form a partnership with __, a physicist with experience in infrared devices, and retired doctor __. The three founded [the company] in 1999.”

This is not an atypical scenario, as seen from this description of the founding of another company: “__ Founder and President, __, has a son in his twenties with type-1 diabetes. Since his son’s diagnosis at age 13, __ has been actively and aggressively researching all aspects of diabetes care and management. In late 2008, __’s son had a dangerous low blood sugar event while driving. Every parent can relate to the fear inspired by that telephone call. For __, it was a call-to-action. __ was determined to find a non-invasive method to alert his son, and the other 24+ million diabetics in the U.S., to rapid and unexpected changes in their blood glucose levels. __ searched the country’s best research universities and was eventually led to the most promising non-invasive continuous

¹ I’ve witnessed this “syndrome” many times during my involvement with noninvasive glucose measurement, and there is no sadder sight in this field.

glucose monitoring (CGM) technology and obtained an exclusive option for a patent license.”

"C8 MediSensors was co-founded by a father trying to help his son living with diabetes, and as a company, we remain dedicated to helping those with the disease," said Paul Zygielbaum, CEO of C8 MediSensors, shortly before it went out of business.

The dark side of the emotional set of considerations is exemplified by those who might have entered this field out of intentional dishonesty or who got so enmeshed in their work that they didn't realize they had begun to believe a fairy tale (or that they had fallen in with thieves and liars). In some cases, of course, the dishonesty just crept in, as it did in Enron or WorldCom, where a company had been built and the truth just couldn't be admitted to the investors or shareholders. When any of these scenarios occurs, there is usually intrigue, cover-up or even worse.

For any of these reasons (and, realistically, because there would be a huge payoff on success), people who have developed a technology are loathe to even consider that they might not be actually measuring glucose, and as a result, tend not to challenge their results as they should (this is termed "experimenter expectancy bias"). In some cases, they have made a leap of faith to the certainty that they will succeed and have tried to negotiate world-wide rights with one of the major players before they have performed even a single definitive test.

Another emotional aspect of this pursuit involves secrecy and competitive intelligence.¹ Because of the magnitude of the payoff, and because many groups are usually working simultaneously toward the same reward, investigators tend to become cautious to the point of paranoia about protecting their information. Although there are very few tales of actual intrigue, each group feels that any information which might be passed to another could impair their chances for getting to success first, while competitive intelligence about other groups might let them know how they are doing in comparison to others.

¹ Having observed or participated in many of these investigations, I can lend personal credence to the tales of unusual measures taken by some companies to protect their own proprietary information or to gain access to that of others.

This issue leads to problems with full disclosure to investors or to consultants hired by them to assess the technology. Venture capitalists tend not to sign confidentiality agreements (consultants generally do) and many talk to each other about the companies that they have been exposed to. Realistically, more information “leakage” occurs this way than any other, but it’s a risk that startup companies seeking funding must take.

Tests of Technologies

A fundamental problem is that, since there is so far no direct technique for measuring glucose inside the body, the approaches are all varying degrees of indirect measurement, and these generally yield subtle, tenuous and variable results.¹ The relationships are not easily seen, and even though the Scientific Method demands experiments that can *disprove* hypotheses (the “null hypothesis,” that glucose concentration absolutely correlates with the chosen parameter in all cases, is impossible to prove), it can often be as hard to disprove these ideas as it is to prove them.

Because continued funding and enthusiasm depend on producing positive results, most people invested in unproven technologies like those described here work tirelessly to prove this null hypothesis, but efforts are often better directed toward proving that the *opposite* is true: that there is no strong, enduring relationship between the parameter measured and reference glucose values. Emotionally, it seems that every success, regardless how small, supports the idea that success is just ahead, but in fact each experiment that disproves what previous investigators found to be true (that there is *no* relationship) is a much stronger indication that success can still be achieved. Every past investigation progressed from faintly encouraging to more promising as it was developed, but to date, the failure mode of each was eventually discovered. This is the reason that the tests for technologies are listed below—any effort directed toward disproving the approach is much more efficient (although disheartening if the test fails) must be pursued as early as possible in the investigation.

It is natural to postpone acquiring what seems like negative information, but the unpleasant reality is that if a proposed technology cannot pass the tests below (or parallel ones designed for testing of likely failure modes of the chosen approach), it is likely it will follow scores of predecessors into oblivion.

Several specific tests have served well over time to evaluate whether a technique has a chance of working (these assume that the technique under evaluation has something to do

¹ Senator (and orator) Everett Dirksen of Illinois loved to use the phrase “gossamer and diaphanous” to describe this kind of relationship.

with spectroscopy, which the vast majority do, but they will also find application in other fields).

Test 1: Unless a spectroscopic technique can see and accurately measure 1 mg/dl of glucose in pure water, it is unlikely to provide acceptable results for physiological levels of glucose in human tissue.

Test 2: Unless a spectroscopic technique can see and accurately measure 5 mg/dl of glucose in a very turbid and complex liquid medium, it is unlikely to provide acceptable results in human tissue.

These are both based on many years of experience. Human tissue is complex, bumpy, heterogeneous, and very hard to get any kind of radiation through without a major distortion from the medium itself. The minimum acceptable accuracy for a commercial glucose device is about plus or minus 20 mg/dl at normal levels (70-130 mg/dl). This means that there can be at most 20 mg/dl uncertainty in the measurement. Without question, tissue is 20 times more complex and challenging than a solution of glucose in pure water, and at least 4 times as complex as the murkiest liquid suspension possible (turbid liquids are made up using materials like [Intralipid](#)[®], a synthetic triglyceride suspension that looks like milk, or small beads that scatter light, such as polystyrene). To make such a test valid, either the pure water or the turbid suspension should also contain the sort of things that are present in serum or blood: albumin, urea, triglycerides and cholesterol, and at their normal concentrations. To make these tests meaningful (and to avoid the possibility that the differences seen are merely due to a decrease in the amount of water present, as described above), comparisons should be made between solutions with the stated concentration of glucose, and others with the identical concentration of a similar “polyhydroxy” compound like fructose, mannitol or sorbitol.

It is reasonable for those providing funding to ask that tests such as these be completed before any testing is conducted on humans. Because, as has been argued, glucose tolerance tests are very likely to generate spurious correlations, and because testing a statistically valid number of subjects (and making accurate reference measurements on

them) is an expensive and time-consuming activity, the technique needs to be wrung out as thoroughly as possible in the laboratory.

In many cases, spectroscopic techniques have shown a good initial correlation which turned out to be due to local environmental variations, leading to test 3:

Test 3: Every tentative correlation must be checked against variations in room temperature and humidity.

This is especially important in near-infrared studies, since the spectrum of water is a major component of every spectrum (and the NIR spectrum of water vapor is complex, temperature sensitive, and varies with humidity). Every laboratory should continuously record and test against these two sources of variation, but they are often neglected in the excitement and confusion of a small startup company.

Rigorous Evaluation of Results

This final law applies to all noninvasive techniques, regardless of the scientific approach. Most important, as many of the anecdotes below illustrate, it is almost always possible to generate a “retrospective correlation” by finding a way to match the data to the reference values. As a result, the only meaningful tests are those known as “predictive.”

Third Law:

Only predictive results count (correlation is *not* causation)

In predictive tests, after the necessary calibration¹ procedures are performed, the subject returns at another time (hour, day, week) to have a measurement made from which a glucose value is calculated, or “predicted.” Only after the result is reported (and written

¹ Calibration refers to establishing the response of the instrument for an individual person, generally by making reference (“true”) measurements with a finger stick measuring device (or YSI) and generating a calibration factor or curve corresponding to the instrument’s response to that person.

down in ink) is a reference measurement made for comparison. To be truly valid, the results should be subjected to analysis by a “disinterested person:” someone who has no stake in the outcome (it’s amazing how many excuses can be found to “throw out” bad data points, or to “adjust” results when one’s livelihood or future employment depends on generating a good correlation). There is no substitute for rigorous, tough, impartial evaluation of results. Anything less runs a terrible risk of distortion by wishful thinking.

Individual Regression

One alternative, a trap that experimenters fall into (or jump into willingly when the results aren’t coming out as desired) is to use “individual (or internal) regression,” where a number of points taken at one time are used to “predict” another point taken simultaneously. Data presented using this technique can be made to look inappropriately good, and have been the basis for much of the false belief and inappropriate funding that has occurred in this field. Consider the following two presentations of a single data set.

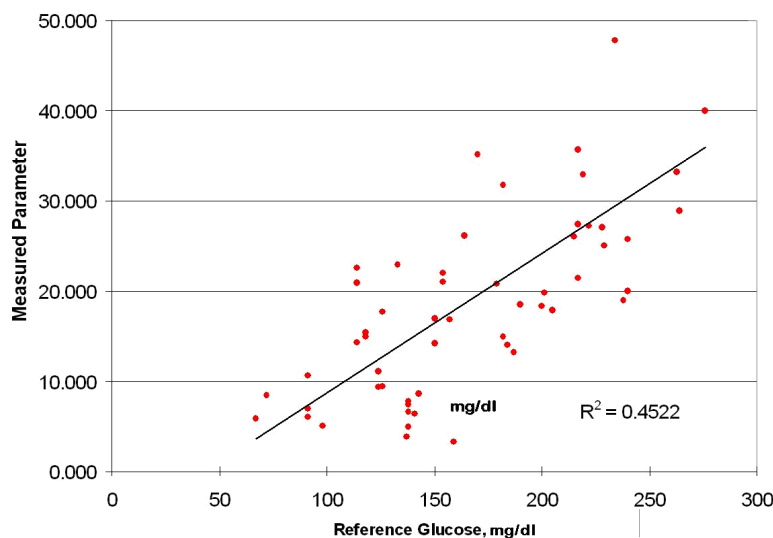

The first graph shows the agreement generated when the data points are generated from a general relationship (the same parameter measured across a number of individuals, and compared to reference measurements, sometimes called “group correlation”). Clearly, this is not an encouraging set of results, and it shows an unacceptable correlation. If, however, the glucose values are calculated by using each person’s individual regression

line (which may be quite different from another person's, and might not even be similar for the same person on another day), the same data set can be prepared to look like the error grid chart below,¹ which would appear to represent a technique with good promise for an acceptable device.

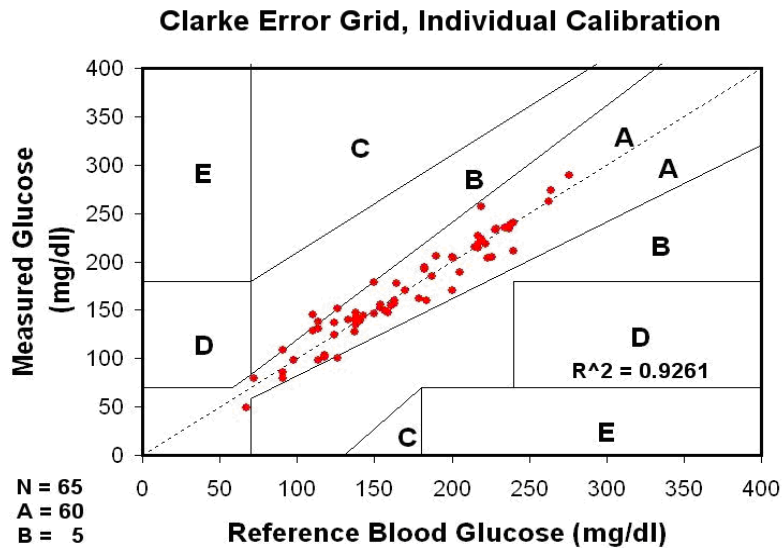

However, none of these results (even the first set) are predictive, since the “measurement” points were generated simultaneously with the “calibration” data points. With a technique showing this degree of scatter, it is very unlikely that predictive results would ever be as good as the individual correlation plot above.

More about Calibration

The ideal noninvasive instrument would not require calibration at all—that is, making a measurement of a parameter would be directly related to glucose concentration, and each value measured would generate a unique glucose result. Owing to the complexity of the techniques that are necessary to generate glucose measurements noninvasively, however, this has not yet been demonstrated. Instead, a spectrum (or impedance, or temperature, or whatever variables are being investigated to represent glucose) usually has a more complex relationship to the glucose concentration (see, especially, the “chemometric”

¹ These are actual data sets that I participated in generating, and they were part of a presentation I made to potential investors while raising a second round of venture capital for Fovioptics, to provide a cautionary example of how poor data can be made to look good. The true correlation was always shown.

techniques discussed in the “Measurements” section above for really complicated calculations).

To get a data set from a given parameter to correlate with reference values taken from the same set of patients, there are a number of corrections that are often necessary. If it has been established that the value has a (linear) proportional response to glucose that goes through zero (that is, a zero value result represents zero glucose), only a single measurement would be necessary to establish the correct response—this is called a slope correction.

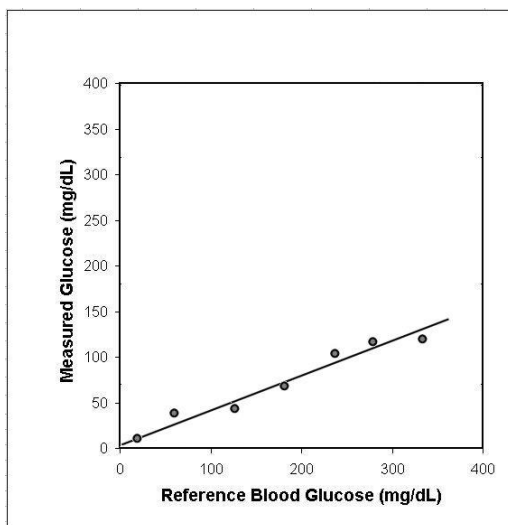

This was done for decades with traditional glucose meters, using “calibration codes” that were set into the meter by the user for each lot of strips to correct the readings.¹ If the experimental result for a new technology gave this kind of response, a single measurement would suffice to establish the calibration line for the results, and each time a new calibration was required (due to instrument drift, changes in temperature, etc.), a single reference measurement would establish the correct response.

If all the results were also offset by a fixed amount, an additional constant (an “intercept” correction) would be needed to add or subtract from each value to correct, and each time

¹ Each lot of test strips was tested at the factory and a calibration code was assigned there—customers have not needed to “re-calibrate” meters and strips since the pioneer days of the 1970s. Most meters on the market in recent years have dispensed with calibration codes for individual strip lots, and are described as “no-coding” meters.

calibration was established or repeated, two measurements at different levels would be required to correct both sources of error, and the accuracy of the calibration would depend not only on the accuracy of the reference values, but on how much difference there was between the two values. If the glucose values are close together, extrapolation of a straight line between them would be subject to substantial error; the farther apart they are, the more accurately the line would represent the true response.¹

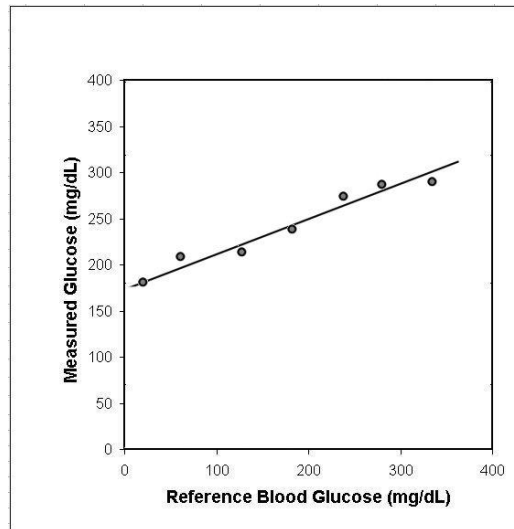

If the relationship of a measured parameter turned out to have a nonlinear relationship with glucose concentration, additional points would need to be measured each time calibration was required, and this could cause additional user interface difficulties and potential errors if the patient were required to perform the calibration.

¹ To establish significantly different glucose values requires making an initial set of measurements, eating food or glucose to increase the level, and then making a second set of measurements. Because glucose levels with this “meal challenge” can change rapidly, device and reference measurement should be made at essentially the same time to avoid a “time offset” source of error.

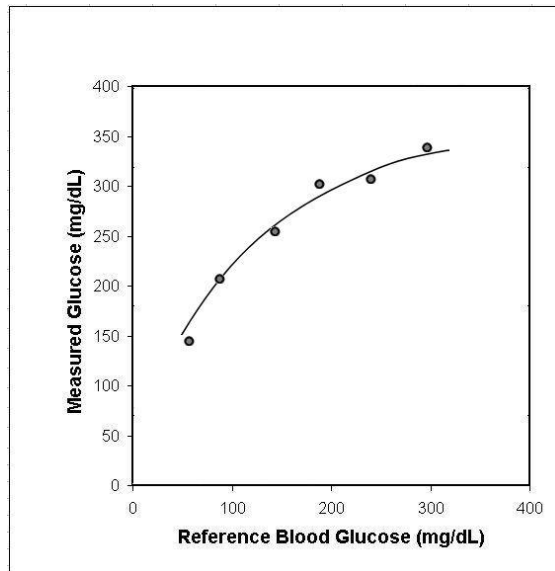

The frequency of calibration (or “calibration interval”) thus becomes very important in assessing the ease of use of a given measurement. If a device could be developed that did not require calibration for an entire year, it would be viewed as very successful. Even once a month calibration with a single finger stick measurement is generally considered acceptable by most workers in the field. Once weekly calibration would impose significant hardships on the user, and a more frequent calibration requirement would probably make a device unacceptable in the marketplace. If a device required a “two-point” re-calibration (with a substantial difference between the two readings, say 100 mg/dl and 200 mg/dl), it would be extremely challenging for people to perform this calibration at home, and it might have to be done in a doctor’s office or clinic. This requirement would be considered strongly negative in assessing the potential of a proposed noninvasive technology.

Individual vs. Universal Calibration

Current invasive blood glucose meters are said to have universal calibration—that is, one calibration setting works reasonably well for the entire population, regardless of age, gender, or ethnicity.¹ Most of the noninvasive technologies proposed to date would be

¹ The amount of red blood cells in the blood, or “hematocrit” can also cause errors with some traditional glucose meters, and a range of values for acceptable accuracy is generally given for each device. Hematocrit values of 30% to 55% cover the vast majority of the population.

expected to be influenced by an individual's anatomy and physiology, and very few have been proposed that could work equally well for all people with no need for adjusting the response to each individual. How easily a device could be "tailored" to respond accurately to a person and how long the calibration could remain valid are important considerations for each proposed technology.

Clinical Studies

Proving that a noninvasive method for glucose works (and learning just how well it works) is not an easy task or an inexpensive one. After the inventor tests himself, then usually a few friends or family members, testing is subsequently done (under the Institutional Review Board protocol described in the introductory section above) by bringing in volunteer patients, usually those with diabetes in order to obtain a range of glucose values, and testing their glucose levels with both the proposed technology and a reference method. Specific instructions may be given to the volunteers to arrive fasting, after a meal (or after an insulin injection), or they may just arrive in random circumstances.¹ To avoid bias in these tests, it's desirable to have a cross-section of the population across age, gender and ethnicity.

If a technology gives good agreement with this first level of testing, studies of calibration technique and calibration interval are usually performed. For this kind of testing, volunteers are brought in and their individual calibration factors are determined by an initial series of measurements. They are then brought back at intervals of a day, a week, or a month to determine if the calibration will "hold" to give accurate predictive results. In these subsequent tests, the glucose value obtained by the noninvasive technique must be obtained before a reference measurement in order to avoid bias. In some cases, it is advised that different people who cannot consult with each other perform the two sets of tests, and that the results be compared only after the testing is completed, and if calculations for the experimental results take some time, the person performing those must be kept "blinded" to the reference values. To do otherwise invites the tendency to

¹ At Fovioptics, one volunteer showed up with a glucose value of only 33 mg/dl, and was sweating so profusely that no testing could be performed. This is a reason that medically trained personnel should always be on site when even these simple tests are conducted.

discount results that do not agree well, with unfortunate consequences. An important source of authoritative information about clinical trials is the website maintained by the U.S. National Institutes of Health: <http://www.clinicaltrials.gov/>.

If a technique survives these initial tests (especially if oral glucose tolerance tests or simple “meal challenges” are used), a series of much more rigorous and expensive tests is eventually required, known as “clamp” studies. In this testing, diabetic volunteers are recruited under strict protocols and have their blood glucose levels carefully manipulated using a combination of glucose and insulin infusions. There is a limited number of endocrinologists or diabetologists who perform these tests, and since there is a need to maintain strict medical observation, they are usually performed at hospitals or specialized clinics. One such organization, with clinics in Germany and California, is called Profil, and conducts these tests for evaluation of both pharmaceutical products and glucose measuring systems.¹ The patient’s glucose values can be manipulated to a greater degree than in glucose tolerance tests, including “M-shaped or W-shaped” profiles that are particularly effective in eliminating spurious correlations, and can be taken into the critical hypoglycemic range to study response there.

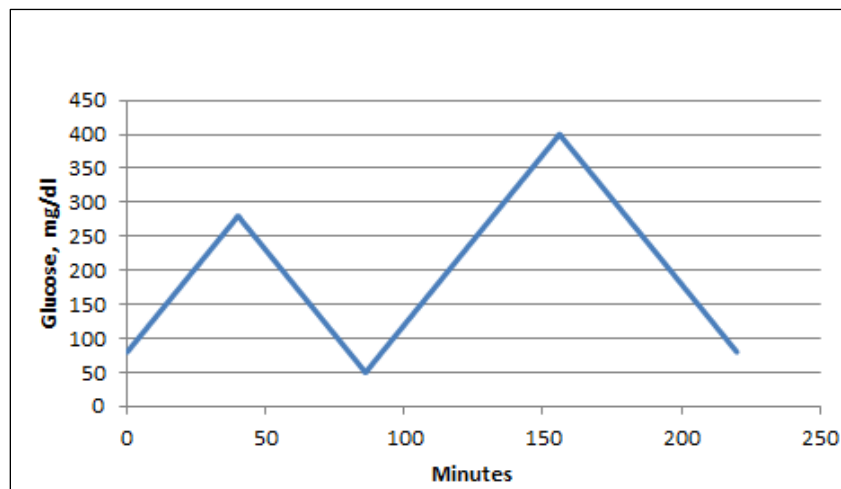

¹ Interestingly, the devices used to monitor and maintain patients’ glucose (at least in 2006) at Profil were “[Biostators](#),” a device developed by Kyoto Dai-ichi and marketed briefly in this country by Miles (now Bayer) in the 1980s. The manufacturer no longer supports these instruments, and there is currently no other known application for them, so the institutions need to maintain their own supply of spare parts and materials.

“M-shaped” Glucose Profile

The cost of this testing can easily run to more than \$15,000 per patient, and if a population cross-section needs to be tested, this can become one of the most expensive parts of evaluating a glucose measuring technology. No other testing protocol, however, has the power of clamp studies, and if an approach is to be considered seriously for product development (beyond the research phase), they must be conducted.

Why Don't People Communicate the Results of their Work?

The main reason is simple: people don't like to describe failure! It's hard to write any technical communication, and it's doubly hard if one has staked his reputation (and perhaps his personal fortune or millions of venture capital dollars) on something that didn't work out. When a company has burned through all the funding it raised, putting down in writing what didn't work is particularly hard and might impair the principals' ability to be part of the next startup that comes along. Realistically, when a company goes under, no one has the time or motivation to publish a paper, especially a negative one, and the principals rarely care all that much if someone else repeats their mistakes.

Only a few people have had enough tenure in the glucose business to see a very broad cross-section of the potential noninvasive technologies, and an R&D executive who spent just a few years¹ in LifeScan, Abbott, or Roche will know only why a few technologies didn't work (that is, the ones they tried to pursue in-house, or with sponsored outside groups). Each company's appetite for noninvasive glucose will have waxed and waned over the decades this industry has been significant, and no one wants to be the lone champion of an idea that doesn't have support from management. As a result, each R&D executive (and each company) has sort of a snapshot view of the field, and, since every attempt to date has failed, all are left with a bitter taste and very little interest in the newest and brightest prospect that comes along.² Even [Bob Coleman](#) (who calls himself a

¹ The tenure of a top R&D executive in a high-technology company is generally short. Changes in the company's fortunes in the marketplace, the failure of research projects, and the impatience of top management with the inevitable delays in new product developments all contribute.

² Nineteen years after my retirement from LifeScan, there is not a single technical person left who overlapped with me, and the experience that had been gained in the company with noninvasive glucose technologies (at considerable expense) has been almost completely lost.

“card-carrying analytical chemist”), had been president of MediSense the original electrochemical blood glucose testing company when it was sold to Abbott in 1996, founder of another company with extensive experience in blood glucose monitoring and who had seen more noninvasive technologies than most over his long career, subsequently founded a noninvasive company (Argose) that pursued two radically different technologies (skin fluorescence and a subdermal reporter molecule) before throwing in the towel.

In many cases, companies have managed to fail in their noninvasive pursuits and have turned to other related areas. It’s a testament to the doggedness of some entrepreneurs that they can keep a company and team together while making a dramatic change of direction after being unable to realize a dream like noninvasive glucose. Among the long-time survivors listed in the first edition of this book in 2006 are NIRDiagnostics, [InLight Solutions](#), Sensys, and Optiscan Biomedical, none of which are now actively pursuing noninvasive glucose technologies,¹ and [Glucorecs](#), the latest reincarnation of [Solid State Farms](#), which is still trying.

¹Of these, NIRDiagnostics and Sensys are no longer in existence, and OptiScan appears to have changed its focus to intravascular testing in the hospital. A company initially dubbed VivaScan (see below) and renamed Grove Instruments departed the twenty-year club in 2015. I considered Wayne March (see the section on optical rotation) the “dean” of the group, but he, too, is now gone.

Technologies and Groups

Near-Infrared: The 800-Pound Gorilla

As mentioned earlier, more money, tears and controversy have revolved around near-infrared spectroscopy (“NIR”) than all the other techniques combined¹.

This field was not the basis for the earliest patent or publication on noninvasive glucose; that honor appears to be held by the technique of optical rotation in the aqueous humor of the eye (see above). The first description of a near-infrared glucose measurement that stirred genuine interest seems to be European Patent Application 0160768A1:

“Spectrophotometric method and apparatus for the non-invasive determination of glucose in body tissues” by Dähne and Cross, researchers at the Battelle Institute in Switzerland in 1985. It is shown in patent compilations as having been referred to at least 57 times by other patents. By the time the actual patent was issued, as EP0160768B1, Battelle had transferred the patent assignment to [Kurabo Industries](#) in Japan; it does not appear that Kurabo continued the investigation but is reported to have worked with Kyoto Dai-Ichi before abandoning the technology.

A European Patent application (EP 3 138 493 A1) filed thirty years later, published in March of 2017, said almost exactly the same thing:

“Referring to FIG. 1, water has the same absorbance of approximately 30 % for light having a wavelength of approximately 1880 nm and light having a wavelength of approximately 2080 nm. On the other hand, glucose has different absorbance values for the light having the above wavelengths. While glucose, like water, absorbs approximately 30 % of the light having the wavelength of 1880 nm, it absorbs approximately 90 % of the light having the wavelength of 2080 nm. Therefore, if the light having the wavelength of 1880 nm and the light having the wavelength of 2080 nm are alternately irradiated to the same location on the human

¹ Since this technology spans all but the earliest attempts, and since it encompasses much of the emotional spectrum as well as the electromagnetic, I will devote a large part of the discussion to historical examples. As always, these are my own recollections, corroborated where possible by discussion with others and by research work, but they are prone to bias, forgetfulness, and personal interpretations. They are presented without malice, even though some of the tales reflect what may have been accidental or even intentional improprieties.

body, they may transmit through the human body to be received in different amounts. It can be concluded that this difference in the amount of light received results from a difference in the absorbance of glucose.”

The approach employed by these researchers (and probably a dozen who followed them) was based on a technique pioneered by Max Liston¹ that evolved into a series of “Abbott Bichromatic Analyzers” where corrections to an optical measurement for an interfering substance such as hemoglobin or bilirubin could be made by making a second measurement at a wavelength where the chromogen for the analyte did not absorb, but the interference did. Many researchers tried in vain to find such “pairs of wavelengths” where the absorbance of things like water, proteins, and fat could be removed from the near-infrared absorbance signal of glucose. The wide disparity of the concentrations, and thus the materials’ absorbances, as described at length below, always defeated this approach.

In a review article, “Noninvasive Glucose Sensing” (Anal. Chem., 2005, 77(17) pp. 5429-5439), Drs. Mark Arnold and Gary Small of the University of Iowa, who have worked extensively in this field, reported:

“It is important to realize at the outset that, to date, no one has proven the ability to measure glucose noninvasively in either human subjects or animal models. Nothing published in the peer reviewed literature or described in the patent literature is proven to measure glucose selectively from noninvasive analytical information. Although many papers and patents claim this ability, none is able to provide the level of proof necessary to establish such a complex analytical measurement. In fact, nearly all the published accounts are most certainly not measuring glucose directly.

□

An observation frequently noted at scientific meetings and review panels is that noninvasive glucose sensing has been under development for more than 15 years without a resulting product. Some evaluators conclude that this lack of success indicates that such measurements are impossible and further development is a waste of time and resources.”

Little has happened since 2005 to change that assessment, but fairly naïve descriptions still appear frequently, such as from Samsung (US 2016/0258814), Lemn Micro Devices (US 2016/0015301), and K. Sairam, “[Design and Development of Non-Invasive Blood](#)

¹ In a last-ditch effort to salvage one near-infrared technology in which LifeScan had invested, I hired Max as a consultant in 1991, but he, like the research group, was unable to resolve their problems.

[Glucose Measurement System using Near Infrared technique,](#)” International Journal of Advanced Research in Computer and Communication Engineering Vol. 4, Issue 7, July 2015, 74-79.

A revealing description of the impact of the changes in distribution of water in the body as a result of glucose concentration changes is U.S. patent 6,990,364, issued to Ruchti in 2006, which states (at column 6, line 66 through column 7, line 9):

“Because the cell membrane is relatively impermeable to most solutes but highly permeable to water, whenever there is a higher concentration of a solute on one side of the cell membrane, water diffuses across the membrane toward the region of higher solute concentration. Large osmotic pressures can develop across the cell membrane with relatively small changes in the concentration of solutes in the extracellular fluid. As a result, relatively small changes in concentration of impermeable solutes in the extracellular fluid, such as glucose, can cause tremendous changes in cell volume.”

Owing to the high concentration of water (about 70% in the dermis, where glucose is usually measured), its absorption dominates the near-infrared spectrum, and small changes in its amount in tissues have large impact on the spectrum of tissue there.

LifeScan’s significant involvement with noninvasive testing began in about 1987. Roger Phillips had moved from Vice President of R&D to directing the noninvasive research program.¹ He instituted a creative approach to learning about nascent technologies that he termed a “poke-around” grant: write up an idea, and if it was considered to have merit, LifeScan would award a grant of \$10,000 to see if the promise developed. The *quid pro quo* was that LifeScan would get a brief written report, the first chance to negotiate for the commercial rights to a promising device, and would have developed a positive relationship with the investigator.

It’s not recorded how many of these were awarded; Roger retired in 1988 and had little further contact with LifeScan. One grant did go to Prof. Dawood Parker in Wales, who turned up later as a principal of Abbey Biosystems, which was purchased by another division of Johnson & Johnson. His approach showed clearly increasing absorbance in

¹ I joined LifeScan in November of 1987 as Vice President of Research, Development and Engineering.

one region of the near-infrared spectrum for glucose solutions of 5, 10 and 15 millimolar (about 90, 180 and 270 mg/ml), but he was unable to reproduce the data that accompanied the grant request, and declined to provide a report after expending the \$10,000.

Another technology for noninvasive glucose was brought to Roger's attention, and even though LifeScan's scientists did their best to evaluate it, they felt it was outside their fields of expertise. A consultant from an academic institution was located and retained who issued a report after evaluating the technology. In general, he said, the technology lacked sound scientific grounding, would never work, and even if it did, would be much too bulky and expensive for home use. However, shortly thereafter, LifeScan received a second communication from the consultant, describing a technology he was seeking funding for that was clearly derived from the technology he was hired to evaluate.

KES: Also in 1987, an arrangement was made by Roger to fund research work by Ed Stark of KES in New York¹. Ed's approach was abstract, theoretical and effectively involved subtracting away the near-infrared spectra of other substances from the spectrum of tissue, in an attempt to see the glucose signal beneath. The approach was slow to show results, and the funding was discontinued in 1988 or 1989. Ed got even to some degree, however. LifeScan relinquished the rights to his research, and Ed patented a similar approach as [U.S. Patent 5,379,238](#) in 1995. When he published his patent, he took advantage of the fact that all patent drawings are in the public domain and illustrated what his device might look like by copying the picture that LifeScan had used in the design patent for its One Touch meter (U.S. Design Patent 318,331).

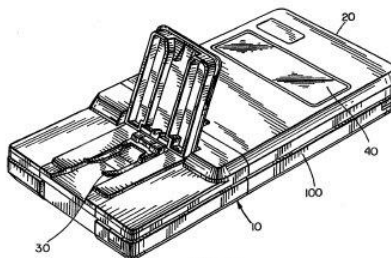

FIG. 1

¹ I had known Ed at Technicon Corporation in the 1970s, where he worked on systems for industrial analysis and I worked on clinical analyzers—see U.S.4,278,887

Interestingly, in 1995, the same year his near-infrared patent issued, he also patented an approach to measurement of glucose using optical rotation in the aqueous humor of the eye (U.S. Patent 5,433,197), assigned to “Bionir.”

NIRDiagnostics: In about 1988, LifeScan was approached by researchers from Waterloo, Ontario, with an idea that again combined improved spectrophotometers with mathematical treatment of the data. Known first as CME Telemetry (then as NIMtek, finally as NIRDiagnostics), the principals were Ted Cadell, a professor of psychology at the University of Waterloo, and Aidan Furlong. Their proposal seemed to have merit, and a relationship was begun with a \$10,000 “poke-around” grant, followed by a comprehensive research and license agreement that continued until about 1992. With the expanded funding, they developed an instrument (with a light source powered by a tractor battery to eliminate power supply variations), and produced data sets of patient spectra which they compared to reference glucose values. Ted’s preferred technique was called multiple linear regression, and he made comparisons to reference glucose values using “retrospective correlation.” With this technique, individual wavelength regions were identified which showed strong correlation with the measured glucose values, and a number of these correlating wavelengths were subjected to the mathematical analysis, producing a strong correlation between the spectral and the reference values.

There were two main problems with this approach. First, the spectra were needed to be differentiated (to give either the first or second derivative of the spectrum with regard to wavelength), a treatment that removed offsets and “tilts” in the spectra but substantially increased the amount of noise in the data (made the curves much more “bumpy”). If the noise introduced by this process was filtered out, the technique didn’t work nearly as well. Second, if the reference values were scrambled¹ so that the spectrum for one patient was matched to the glucose value of another and then processed, equally good correlations could be obtained. This is a dead giveaway that the data were being “overfit;” that is, there was enough variability in the spectra to correlate with almost any

¹ I termed this process “pseudoglucose,” and it is a valuable technique for uncovering false correlations between patients’ glucose values and data obtained in the laboratory, for many techniques.

data set. The illusion was completely destroyed when it was shown that an equally strong correlation of the spectra with historical stock market data could be shown, and the relationship was dissolved in the early 1990s. They were later funded briefly by Abbott, but that relationship [reportedly](#) ended in about 1997, and even an investment of more than \$5M by [Motorola](#), beginning in 2000, did not produce a product.

As an example of the persistence of companies in this field, in August of 2004 the president's message on NIRDiagnostic's website stated: "...the primary research goal of the company remains the completion of GlucoNIR™, a non-invasive glucose self-monitoring device, aimed at the \$4.5 billion diabetes self-monitoring market. GlucoNIR™ will offer instant results and pain free testing; two highly desirable characteristics for people with diabetes who must monitor their blood sugar levels several times per day." They are not the first company to keep the dream alive for over fifteen years,¹ but an announcement of accuracy improvements by the company in 2006 was met with considerable skepticism:

"CAMPBELLVILLE, ON, July 18 [2006] /CNW/ - NIR Diagnostics Inc. (TSX Venture: NID), a leading-edge developer of handheld spectroscopy based medical instruments, announced today that it has achieved a level of accuracy in sponsored feasibility testing of its light-based in vitro glucose monitoring device that is sufficient to advance to development of a prototype and initiate clinical trials.

[...]

The results from an in-vitro bench top device of 224 patient samples demonstrated an R(2) value of 0.95. "Achieving results of more than 90 percent in the A zone and 99.5 percent in the A and B zone of a Clark Error Grid on a bench top device signals a technological breakthrough in the accuracy of glucose monitoring with a reagentless light-based device. No other light-based device that we know of can boast this level of glucose accuracy with components suitable for a low cost hand-held device format," said Ash Kaushal, Vice President Technology of NIR Diagnostics."

¹ For Ted Cadell, I have only fond memories. A fellow wine lover, he not only visited my vineyard and helped out during harvest but also provided me with the finest bottle of Burgundy (a 1959 Vosne Romanée) that I am ever likely to taste. It was the final bottle at my retirement wine tasting at LifeScan in 1998 and will be remembered for a very long time by those who were there.

VivaScan: In about 1991, another group called VivaScan (clever naming in view of LifeScan) in Worcester, Mass., was brought to LifeScan's attention with the forerunner to several other techniques that can be grouped as "squeeze" techniques. The principle of this approach is to measure a transmission spectrum of tissue (in this case, the "web" between the thumb and finger), then compress the tissue to decrease the amount of blood in the path and measure again. By using sophisticated optical and electronic "bridge" techniques, it was hoped to get enough signal to detect the decrease in glucose from the blood that was squeezed out by the compression. The difficulties in making this practical were the extreme variability of the optical properties of tissue and the difficulty in reproducing the location and spectrum, and the fact that more glucose is present in the interstitial fluid between cells, which is not squeezed out, than in the blood vessels, where it might be expelled.

After a lot of hard work, and a lot of critical analysis, it was determined that this technique did not show continuing promise, and LifeScan's funding was discontinued. A year or two later, however, VivaScan was brought to the attention of the Johnson & Johnson Development Corporation (JJDC), J&J's in-house venture capital fund, by Dean Kamen, an "Inventor of the Year" from New Hampshire, who tried his best to convince both J&J and LifeScan that the technology was truly great, and that LifeScan was incredibly foolish to have stopped funding it. Since Dean, in addition to always wearing work boots and denim clothing, never returns phone calls, it made life at LifeScan very uncomfortable until he moved on to greater things in a few months. More about Dean later.

VivaScan, now renamed Grove Instruments, received first \$3 million tranche of a \$5 million Series B-1 round of equity from undisclosed private accredited investors in December of 2012. The round came nearly a year after a \$6 million Series B round that closed late [in 2011]. If clinical trials had gone well in 2013, the CEO expected to initiate the process of seeking Food and Drug Administration (FDA) approval for the device in 2014. In late 2014, the company announced that it had completed a "Landmark Clinical Milestone" of having a durable calibration that lasted 24 hours (insiders were not equally enthusiastic about the results). Then on April 15, 2015, came the [announcement](#) that

Grove had filed for Chapter 7 bankruptcy, with debts of more than \$3 million and assets of less than \$100,000.

A similar technical approach has been taken by LighTouch Medical, founded in 1997, although they hope to use Raman spectroscopy, a variant on infrared, to make the differential measurement after the tissue squeeze. Their website said, even in 2015: “When it comes to non-invasive, fast and painless technology for continuous monitoring of glucose and other analytes in the blood LighTouch is number one. No other diagnostic technology is faster and more reliable.” It’s also not approved for sale. Charles (Chuck) Peterson, M.D. was listed as president of the company. He had a long and distinguished career as medical director and CEO of the Sansum Medical Research Institute in Santa Barbara, where he was witness to a great number of noninvasive glucose attempts. As of 2017, the website is gone, the Syracuse, NY, address is missing, and [records](#) remain only of a company of the same name in Bryn Athyn, PA, with Joseph Chaiken listed as the CTO.

It was also suggested by researchers from Agilent Technologies (U.S. Patent 6,113,541, derived from an earlier patent, 5,817,181, by the same inventors when their employer was identified as Hewlett Packard), squeezing the finger to reduce the volume of blood in it and using either near-infrared absorbance or “blood-scattering” detection methods in an attempt to measure glucose (a suggestion was also included that iontophoresis could yield additional information about the amount of glucose in the finger’s blood during analysis).

Rio Grande Medical Technologies (InLight Solutions): From Sandia National Laboratory in about 1990, had come hints that a noninvasive, near-infrared glucose research project was beginning, but it was so carefully cloaked that repeated inquiries, as well as a visit there in 1991, failed to ferret it out. Some details eventually leaked, and in 1992, at the Oak Ridge Clinical Chemistry Conference, Ries Robinson made a public disclosure of the intent (it was his project at Sandia that had been so carefully guarded).



In early 1993, Ries founded Rio Grande Medical Technologies (“RGMT,” later renamed InLight Solutions), and began serious negotiations with several glucose monitoring companies to decide who would be granted the right to commercialize the technology. After extensive discussions (including a session in their offices at which a stenographer was retained to insure that all confidential communications were documented) and multiple contract revisions, an agreement was reached in October of 1993 (the picture above shows Rick Thompson, then CEO of LifeScan, Ries Robinson¹ and John Smith).

Ries is an exceptional individual. With bachelor’s and master’s degrees in mechanical engineering from Stanford and an M.D. from the University of New Mexico Medical School (he studied electrical engineering during medical school to stave off boredom), he brought a broad technical background, a triathlete’s competitive spirit, a driving, determined personality, and little industrial experience to the new company. He was certain that the problem would be solved “within a year” so his company would be ready to begin receiving royalty income shortly after and move on to other challenges. The association between LifeScan and RGMT/ILS continued for over ten years, with

¹ Rick Thompson went on to become CEO and Chairman of Aradigm, a company with funding from Novo Nordisk that tried for many years to develop an inhaled insulin preparation, and sat on the InLight Solutions board of directors. He later became CEO of Luminous Medical, spun out from InLight to address the hospital critical care unit continuous monitoring market. That company closed down in 2011.

LifeScan funding virtually all of the company's glucose activities. Each year yielded significant insights into the problem, but with each insight came new challenges to be resolved. Finally, after six changes in technical leadership at LifeScan, the relationship was effectively ended in 2004, and rights to the technology reverted to InLight.¹

Near-infrared spectroscopy is primarily performed with two different classes of instrumentation, and the path followed by RGMT was "interferometry," or "Fourier-Transform" instruments (the other, as used by the group at Sensys, is called "dispersive," and will be described later). These are instruments based on a Michelson-type interferometer, where two light beams interfere with each other, and the result is a frequency-based compilation of the signal called a Fourier transform. The details aren't important here because the signal is quickly converted to a standard spectrum of intensity (or absorbance) vs. wavelength. Those who work with this technique will aver its superiority over the dispersive alternative, while those who worship at the other church disagree. As will be seen, it hasn't yet made much difference in results.

The various "multivariate" ("chemometric") mathematical techniques for extracting correlations from the complex data generated in the near-infrared also have their adherents and detractors. An interesting exchange occurred between Bob Rosenthal of Futrex (see below) and Ries Robinson of RGMT when both presented papers at the Oak Ridge Clinical Chemistry Conference in 1992. Bob was strongly advocating "multiple linear regression" (MLR), while Ries insisted that the correct path was the technique known as "partial least squares" (PLS). The other similar technique that appeals to a number of practitioners is called "principal component regression" (PCR).

The ten years of association were interesting, to say the least. Ries was fiercely independent, and strongly resisted outside suggestions about how the research might be

¹ I managed the interface between LifeScan and RGMT/ILS from 1993 to 1998 when I retired as LifeScan's Chief Scientific Officer, and then until 2003 as a consultant. That year, I was called in to meet with the then-current VP of R&D to terminate my consulting relationship. After driving three hours and signing in at the front desk, I needed to use the restroom. As I finished, my LifeScan visitor's badge slipped off my shirt and dropped into the urinal. I have no idea what that might symbolize. InLight never commercialized a noninvasive glucose monitor.

conducted, even from the people who were supplying the funding.¹ The initial intent of the program was to produce an instrument with “universal calibration,” that is, the instrument could be applied to anyone’s tissue (they first looked at the fingertip, then the nail, then the forearm) and give an accurate glucose result. When that proved impractical, the goal was relaxed to allow “subgroup” calibration, where people with similar tissue optical properties could get a result, and finally to a technique for individual calibration that was renamed “tailoring” (the analogy was that a new suit wasn’t required for each person; simply adjust the sleeve length, cuffs and waistband).

Many long, difficult and contentious meetings were conducted—LifeScan personnel would fly to Albuquerque one month, and RGMT people would trek to LifeScan’s headquarters in Milpitas the next. Hundreds of experiments were suggested, rejected, revised and performed, and along the way some remarkable advances in the state of the art of instrumentation were made, and some virtually unsolvable technical problems were surmounted by a brilliant, dedicated group of engineering and scientific minds—possibly the most capable group assembled in New Mexico for a single purpose since the Manhattan Project. Sadly, the goal of accurate, reliable glucose results remained always “just over the horizon.” Along the way, [Johnson & Johnson Development Corporation](#) (the venture capital arm of the Corporation established to keep an eye on new technologies) took an equity position in the company.²

As alluded to earlier, the esoteric nature of most of the techniques used for exploring noninvasive blood glucose measurements constitute a dilemma for most corporate managers in the traditional blood glucose industry, in which profitability depends on brand loyalty to generate repeated test strip purchases. On one hand, their company’s

¹ When he was faced with my demand to produce a certain level of accuracy before conducting any additional measurements with human subjects, he named it the *Simpsons’* related “Smither Challenge.” By the time the goal was achieved and the necessary instrumental improvements to allow accurate measurements were in place, he reluctantly agreed that requirement was appropriate, and that acceptable results with human subjects could never have been produced with the stability of the earlier instrumentation.

² A fact which probably enabled InLight to extend their funding from LifeScan, because to discontinue meant LifeScan would have to write off the investment as an expense, and that amount combined with any termination charges in the contract might have had a bigger impact on LifeScan’s bottom line than the cost of funding the research program for another year.

livelihoods was perpetually threatened by the almost-weekly announcements that “someone, somewhere has finally developed a practical noninvasive glucose meter” (every member of the board of directors seems to get these in daily news alerts, and each one needs an explanation of why it’s not the end of the current business model); while on the other hand, each company is conducting their own research programs (they tend to keep some kind of effort going on in-house or outside), from which they get perpetual semi-annual projections that the answer is “just around the corner,” in reports that are filled with incomprehensible graphs, mathematical equations, and explanations they can’t begin to understand. A retired CEO of one of the “Big Four” companies confided that he never understood what his noninvasive research group was doing but was unwilling to terminate the program because they “just might succeed” (or someone else might, and he needed a “window” into what was going on elsewhere). He said the group always had “great progress” to report when it was time to calculate the budget for the upcoming year but never seemed to get to the end of the road.

One of the ways companies deal with complex problems is to hire a consultant. A consultant who was revered by Johnson & Johnson, and who was trotted out by the corporation at technical management meetings with the subliminal message: “Why can’t you guys be inventive like him?” was the aforementioned Dean Kamen. Dean had invented an early insulin pump and the iBot, a wheelchair with revolutionary balance capabilities so it could go up or down stairs, and raise its occupant up to an eye-level height to converse with people who were not so constrained (this was the forerunner of the famous, or infamous, Segway scooter that received so much attention). The development and commercialization path (sponsored by J&J) for the iBot was anything but smooth, but there were plenty of places to point and stories to tell about why it was so slow to reach the market, and why it cost so much when it did.¹

Probably at corporate urging, Dean was retained by LifeScan to evaluate the RGMT technology in the late 1990’s and to determine if management was starting to throw good money after bad. He flew his private jet to Albuquerque, listened to hours of presentation

¹ In May of 2016, there was an [announcement](#) that Toyota would attempt to relaunch the product.

and got his glucose measured (it came out amazingly close, as it almost always does for people who don't have diabetes). Dean submitted his evaluation, which was generally not positive about reaching the goal in a reasonable time. However, his message to J&J included a suggestion that he had much better ideas than InLight of how to pursue noninvasive glucose measurements, and if J&J would fund him, he could promise results. J&J declined his offer, which was probably fortunate for both parties.

By 2003, it appeared to LifeScan that InLight had run out their near-infrared glucose investigation about as far as it could go—the results were not good enough, especially in the critical hypoglycemic range, and the amount of money necessary to make meaningful improvements began to appear impractical. Since similar results began to be heard about the alternative technology in the Sensys group described below, LifeScan decided it was time to wait for a technology breakthrough before investing further, and ended its relationship with InLight.

InLight spun off a company in 2004 called VeraLight (now owned by the Canadian company Miraculins, which in 2016 renamed itself [Luminor Medical](#)), with a charter to refine their glucose monitor as a device to screen people for diabetes (they had earlier generated a biometrics company called Lumidigm in 2001, and another called MolecuLight in 2003 to do cervical cancer screening; more recently, they formed Luminous Medical to address continuous glucose measurements in intensive care environments¹). They also pursued the use of near-infrared spectroscopy for alcohol measurement through their [TruTouch](#) company. What appears to be a very similar spectrometer is used for at least part of the screening measurements, alcohol, and glucose, and is elegantly designed, if a little large for everyday use (below).

¹ The company closed down in 2011.



SCOUT DS[®]
DIABETES SCREEN

**No Blood
No Fasting
No Waiting**

* Regulatory Clearance in Canada and European Union
USFDA Clearance in Pre-Submission

by **miraculins**



InLight Glucose Measurement System

Instrumentation Metrics (Sensys): During 1995, LifeScan received a visit that was surprising on two counts. First, the senior member of the duo was John Kaiser, who had headed up Boehringer Mannheim Corporation's blood glucose business during LifeScan's ascendancy in the early nineties. Relations between the two companies had been frosty at best during the time LifeScan deposed BMC as the world market leader. However, there had been a change in ownership there, and John had become a Silicon Valley entrepreneur at Biocircuits (and later at C8), so he and LifeScan's president, Dick Wiesner, could meet on civil terms.¹ John brought along Steve Malin, the founder of Instrumentation Metrics, who demonstrated a table of correlations he had generated for

¹ As of 2006, John Kaiser was still on the Board of Directors of Sensys (but see his obituary notice in early 2013, above under C8 Medisensors).

virtually all analytes of biological interest—molecules and ionic species alike—using near-infrared spectroscopy^{1,2}.

Having had experience with four or five near-infrared companies, it was already a stretch for LifeScan to believe that the listed correlations could be generated for molecular analytes like glucose and bilirubin, but seemed almost impossible that someone could obtain accurate near-infrared results for sodium, potassium and calcium, which have virtually no signal in this wavelength region (this doesn't mean it *couldn't* be done, because ionic species can have an effect on the spectrum of water, which is what dominates a near-infrared spectrum of tissue).³ Where Inlight (ILS) used an interferometer as the basis of their instrumentation, IM was focused on a wavelength-dispersive optical design that spreads the spectrum in space (as a prism separates the rainbow colors from white sunlight), then creates a recording of the spectrum to determine concentrations.

IM (the name was changed along the way to Sensys) ran parallel to RGMT/ILS for many years—publishing remarkably similar patents within months of each other, seeming to uncover much the same problems and solutions in similar time frames, and seeming to have similar accuracy issues (so much so, that each company thought that there might be a “mole” in the organization, but it was never clear *which* organization, if either, might have been infiltrated). Each company, with its own instrumentation approach, has several dozen patents, but both appear to have wound up about the same place: **If** the sensor probe (light source and detector connection through fiber optic or similar light conduit) could be located at exactly the same place on the skin with exactly the same pressure, and **if** the skin had the same degree of hydration (and possibly temperature), and **if** calibration

¹ I had met Steve years earlier at Kallestad Diagnostics, the predecessor of Sanofi Diagnostics Pasteur/Beckman Instruments in Chaska, MN, during an interview visit there just before I joined LifeScan.

² Steve is currently a technical advisor at Artemis Biomedical Technologies, a company pursuing noninvasive glucose measurements in the NIR.

³ I sent Steve the best near-infrared spectrum of tissue we could produce, and asked him to tell me the concentration of any of the analytes in his list, but I never heard from him again. Repeated phone calls to his office and cell phone were never answered, nor were messages returned. Some years later, after Steve had been ousted from his company, I had a conversation with another former employee who said that they knew it was impossible meet the challenge with a spectrum measured on a different instrument and simply decided not to respond.

with a finger stick reference were made on a regular basis, the results would be *almost* clinically acceptable, at least at elevated glucose levels. With all these caveats, it was unlikely that either would ever see the light of day as a home use device. Even if they had, each is a reasonably delicate piece of optical apparatus, with moving optical parts that require precise alignment. If one of these devices were made, it would likely have sold for many thousands of dollars.

After nearly a decade of insistence that the people at Sensys were truly measuring glucose, it appears that they may have finally arrived at the conclusion that they truly weren't. In an unusually candid statement in a patent application (20060116562), they seem to concede as much:

"[0048] A major component of the body is water. A re-distribution of water between the vascular and extravascular compartments and the intra- and extra-cellular compartments is observed as a response to differences in glucose concentrations in the compartments during periods of changing blood glucose. Water, among other analytes, is shifted between the tissue compartments to equilibrate the osmotic imbalance related to changes in glucose concentration as predicted by Fick's law of diffusion and the fact that water diffuses much faster in the body than does glucose. Therefore, a strategy for the indirect measurement of glucose that exploits the near-infrared signal related to fluid re-distribution is to design measurement protocols that force maximum correlation between blood glucose and the re-distribution of fluids. This is the opposite strategy of the one required for the direct measurement of blood glucose in which the near-infrared signals directly related to glucose and fluids must be discriminated and attempts at equalizing glucose in the body compartment are made. A reliable indirect measurement of glucose based at least in part in the re-distribution of fluids and analytes (other than glucose) and related changes in the optical properties of tissue requires that the indirect signals are largely due to the changing blood glucose concentration. Other variables and sources that modify or change the indirect signals of interest should be prevented or minimized in order to ensure a reliable indirect measurement of glucose."

Under the two names, Sensys and ILS burned through well over \$100 million in venture (Sensys) and corporate (ILS) funding. The amazing thing is that, combined, they don't even hold the record for expenditures in near-infrared noninvasive glucose, nor has either one seen anything like the legal troubles of the following two companies, Biocontrol and Futrex, described below.

After Sensys ceased operating, their patents were sold to GLT Acquisition Corp, a subsidiary of [Masimo](#) (which also owns patents purchased from the defunct GlucoLight Corporation), a leading company in pulse oximetry with a long-term interest in

noninvasive glucose measurement. Masimo's other subsidiary, [Cercacor](#), has obtained a number of patents in the area of near-infrared noninvasive glucose monitoring over almost 25 years, and has filed additional patent applications. It's also rumored that scientists from Sensys moved to Cercacor after the former closed down, and some went from Cercacor to Apple, if for a brief time (but see the section regarding the long-dead Biocontrol near the end of that section for an example of the irony this field continues to produce).

Zyomed is one of the latest entrants in the near-infrared field, with its first U.S. patent (US 9,448,164) appearing in 2016. It was founded by Sandeep Gulati, a computer scientist who had a long association with NASA and the Jet Propulsion Laboratory, and a background in signal processing techniques.¹ Based on the understanding that the multivariate techniques used in most of the previous investigations in this spectral region did not have the power to separate the extremely small glucose signal from other “confounders” in the near-infrared spectrum of tissue, they developed a new approach to treating the data, called “collision computing.”

Glucosense is a new company with the same name as an earlier company (see below under RF/impedance measurements). It was created by NetScientific in London and the University of Leeds, and is based on technology from Dr. Jin Gose (of the Institute for Materials Research in the University of Leeds' School of Chemical and Process Engineering). The company issued a press release In July of 2015 titled “New non-invasive glucose monitoring device could transform lives of people with diabetes,” and received quite a bit of publicity for the laser-based system that was based on a near-infrared fluorescence technology. As of January, 2017, although a URL for still exists for <http://netscientific.net/clients/digital-health/glucosense> (and there was still a [YouTube](#) video), the company is no longer listed on NetScientific's portfolio page.

[Cnoga](#) is an Israeli company that has developed the “SoftTouch Non-Invasive Finger-Mounted Device,” and conducted a clinical study there between about 2008 and 2012.

¹ I have acted as an advisor to this company since it began work in the field in 2010, and I am a co-inventor on some of its patent applications.

Patents issued between 2008 and 2013 shed little light on the principal used to convert readings of visible and near-infrared light to glucose concentrations. A not very enlightening example of the approach is from a patent application filed in November of 2012: “...physiological or biophysical properties are all indirectly connected to the spatial-temporal Red, Green, Blue colors, and their potential, intensity, irregularity, regularity, vividness, saturation, deformations, correlation, auto correlation, cross correlation, histograms, look up tables, diffusion, potential, heat, absorption, and derivations.”

A newer patent application may indicate that the original, fully noninvasive technology did not work as well as planned and required the addition of an invasive measurement to perform. US Patent Application 20120191001 is titled “Combination Non-Invasive and Invasive Bioparameter Measuring Device” and says, in part, “For example, if the bioparameter is glucose, the patient may stick himself, places the blood on the test strip of the invasive component and then insert the test strip into the invasive component of the combination device...” This is not the testing sequence followed by any of the blood glucose meters on today’s market, and indicates a lack of experience with glucose testing. It is also another example of “making the hammer heavier” (see the section on “combination techniques” below).



A 2014 entrant in the near-infrared field was described in a very naïve article in a trade magazine, *Electronic Design News*. It included this picture, the first report of the “[Biopie](#),” which has not been heard from since.



Biocontrol: About 1988, the first reports appeared regarding a company called Biocontrol, in the unlikely city of Indiana, Pennsylvania.¹ Their first patent application was filed in 1990, and became U.S. Patent 5,070,874 in 1991.² It described a fairly simplistic approach using only a few near-infrared wavelengths and derivatives of the spectrum to eliminate offsets and slopes that confused the measurement (see the description of this technique under NIRDiagnostics).

As time went on, Biocontrol went public with tremendous hype about its promise for making a practical near-infrared device they termed the DiaSensor, split off a division to

¹ I spoke with David Purdy, president of the company, in about 1988 about a potential collaboration or sponsoring of their research, and he seemed like a person whose motives were proper, and who was genuinely interested in solving the technical problem. He told me they were not interested in working with LifeScan, and that they intended to build a completely integrated company to make and sell the first noninvasive glucose monitor.

² They continued to generate press, and by the time I visited their facility (in 1992 or 1993), I met only with marketing and sales executives Anthony Feola and Glenn Keeling (CEO Fred Cooper was out of town), and they showed me some correlation plots for glucose. When I asked how many employees they had, the reply was: “Five in research and about 35 in investor relations.”

market the device called Diasense, and proceeded to raise funds as needed by additional offerings of stock. They lived on press releases, and “hype” messages appeared regularly on stock bulletin boards, with multiple exclamation points, about how BICO (their stock symbol) was about to hit it really BIG!!!! In January of 1994, they filed a 510(k) application with the FDA, but the application was evaluated and rejected because the FDA found the results generated with their device were not nearly good enough.¹

Fred Cooper responded predictably, testifying before a congressional subcommittee that the FDA was biased, didn’t understand his technology, had a serious conflict of interest with some of its panel members and consultants, and calling for the ouster of the agency’s director, David Kessler (neither Congress nor the FDA were impressed with his diatribe).

At the FDA panel meeting for Biocontrol’s second 510(k) submission, the company produced successful data on only eight patients in its clinical trials, despite enrolling 85. Twenty-two were eliminated due to malfunction of the machine; two were eliminated because glucose levels did not vary sufficiently to calibrate the machine to them. Of the remaining 61 patients, 47 had the machine successfully calibrated to them. The company chose to follow 23 of them for 30 days, and the FDA did not object, according to the company. The eight successes were found among those 23 subjects.

Supporters (or possibly employees) of the company even sent out emails like this one with a suggested letter to send to the FDA:

“BICO noninvasive glucose sensor!!!!!!!!!!

Email Susan ***** PR for BICO : "Susan *****" <*****.**** at compuserve.com>

¹ LifeScan, like every other company in the business, was aware that Biocontrol had filed a 510(k) application with the FDA. Because the FDA had no specialists who were aware of the subtleties of near-infrared measurement of glucose, LifeScan offered to meet with the FDA to acquaint them with what we had learned from our years of research in the field. We met with their scientific staff and provided an understanding of the complexity of extracting glucose signals from tissue spectra. One motivating factor for this meeting was that we were quite sure that Biocontrol did not have a viable device, and we didn’t want future approval processes complicated by a device that was prematurely released for sale.

A noninvasive glucose sensor that could make testing easier thereby granting tighter control of our glucose levels has been in the FDA approval process for two years. Biocontrol Technology, Inc.'s 510(k) Notification for the Diasensor 1000 noninvasive glucose sensor will have a panel review by the FDA at 9:00 a.m., February 26, 1996 at the Holiday Inn Gaithersburg Ballroom, 2 Montgomery Village Avenue, Gaithersburg, MD. Following this meeting, which is open to the public, the FDA will vote on BICO's requested market approval. If you feel that your overall health, or that of a diabetic in your care, would be aided by such a sensor and would like a chance to express your opinion, attend the panel review. If that is absolutely impossible, write a letter. The address follows, together with a suggested wording. Of course, any wording will do:

Cornelia Rooks

Center for Devices & Radiological Health

Food & Drug Administration

2098 Gaither Road

Rockville, MD 20850

I am a diabetic or caring for a diabetic, and I understand that the Diasensor 1000 noninvasive glucose sensor will have a panel review by the FDA on February 26, 1996. If it were possible, I would attend to voice my support for such a device. Since that is impossible, however, I am writing to urge you to approve this noninvasive glucose sensor for sale. To have such a device available would be of great help in the mandatory frequent monitoring of blood glucose levels. Unless you have been diabetic or cared for a diabetic, you cannot understand the pain and complications of the finger pricking now necessary.

Sincerely,

NAME:

ADDRESS:"



The First Non-Invasive Glucose Sensor

- No More
Finger Sticks
- No More Pain

Diasensor 1000™

Accurate control of diabetes requires as many as four or more finger-blood tests a day; a painful and debilitating chore for the diabetic. Now glucose levels can be measured as frequently as desired - simply, painlessly, accurately and quickly.

- **Measures glucose non-invasively.**
- **Each machine will be calibrated to the diabetic.**
- **11" x 18.5" x 11" - Lightweight & portable.**
- **No supplies needed.**

The Diasensor 1000™ is now available at The London Diabetes & Lipid Centre where a dedicated team of experts will be available for consultation, information and advice.



at The London Diabetes & Lipid Centre •
115 Harley Street • London W1N 1DG UK • Phone 071 487 4470 • FAX 071 487 3527

DIASENSE, UK LTD.

an affiliate of Biocontrol Technology, Inc.

In an open letter to stockholders and people with diabetes, CEO Fred E. Cooper defended the company's position that eight patients provided sufficient data on efficacy and safety: "It was enough because for those eight patients, 263 data points...were submitted to FDA--that's an average of 32 data points per patient. Firms currently using finger stick technology only submit an average of one data point per patient for devices they are attempting to get cleared. That means 100 data points submitted equals 100 patients studied. Therefore, 263 data points submitted for the Diasensor 1000 is equal to having tested 263 patients--a substantial test size." In the 10 months following the panel meeting,

Biocontrol withdrew, revised, resubmitted, and then again withdrew a 510(k) application for the device.¹

Cooper then hired Jack Nard, a well-known critic of corruption in government, (and a leading proponent of conspiracy theories) to investigate the FDA. But by this time, stories had come out in the press, especially the Pittsburgh Post-Gazette, describing that CEO Cooper was bringing home an annual salary of \$700,000, even as the company had lost \$66 million in the previous few years. In fact, executives Feola, Keeling, and Cooper among them managed to rake in between \$10M and \$20M during the time they ran the company into the ground, while losing over \$220 million of investors' money. In addition, it turned out that the company had violated a number of securities laws in their initial and follow-up offerings, and restless stockholders had begun to file class-action suits, hoping to recover some of their bad investments.

In 1997, plans were announced to sell Diasensors to customers in the Philippines (which had much less stringent medical device regulations than the United States). In the same year, an article by Patricia Sabatini appeared in the Pittsburgh Post-Gazette, detailing rigged demonstrations, where the device was programmed to display acceptable results, and alteration of the result grids for the FDA by using “white-out” to remove data points that were dangerously erroneous. By 1998, they announced that four orders had already been received, and two devices had been delivered.

¹ Somewhere around this time, I received a call from Glenn Keeling (ironically, I took the call in a parking lot of the University of New Mexico while visiting RGMT), who volunteered the information that they were able to get good agreement only at very high glucose values, and that they were interested in selling the technology or the entire company, if the price were right. Based on their lack of success, I indicated that LifeScan had no interest in acquiring either. Within a few days, Biocontrol issued a press release stating that they were “in talks” with Johnson & Johnson to negotiate a purchase of their company and all its technology.



In 1999, a year when the FDA placed an order for a Diasensor (to “gain knowledge of the performance of such devices,” they said), the subsidiary marketing company changed its name to Diasensor.com, which had greater appeal once the Internet technology boom was underway. In late 2000, David Purdy announced his resignation as chairman, saying he could no longer “be associated with the marketing and development of the Diasensor(R) 2000 Noninvasive Glucose Monitor system in its present circumstances.” He received \$912,000 in severance. Also in 2000, the company settled one class-action stockholder suit by paying out \$3.45 million.

The lack of progress, together with the mounting Securities and Exchange Commission (SEC) problems and class-action stockholder suits took their toll, and in September of 2002, Fred Cooper pled guilty and was convicted of not only pledging company funds to guarantee personal loans, but also of failing to pay hundreds of thousands of dollars in federal income tax over a number of years (his two fellow officers were not charged). His pay for the previous three years had averaged about \$1 million. The convictions carried a maximum penalty of 13 years in prison and \$1.2 million in fines. On December 23, 2004, however, Cooper was sentenced to just 36 months’ probation, including six months of house arrest. Third Circuit Judge Sloviter dissented on a number of grounds, including her belief that the millionaire defendant had effectively bought his way out of prison by suddenly doing good deeds for underprivileged inner-city kids after he became aware of the investigation that led to his conviction.

Finally, in June 2005 (it takes a long time for a corporation to die), this announcement appeared as a footnote to what was surely the final financial statement:

“The following pro forma adjustments are incorporated in the pro forma condensed statements of operations and are expected to have a continuing impact on the Company:

2. Reflects the elimination of all prior BICO and CXC operations. By the end of the reorganization BICO had no employees, no operations, and no assets, all of its prior businesses were gone, as were the subsidiaries through which its operations had been conducted”

(*n.b.* This company should not be confused with Biocontrol Systems, Inc. in Bellevue, WA—they’re a legitimate company making instruments to measure eye and body movements.)

But while BICO may have died, it appears Diasense did not, and has undergone many transitions--see <http://www.hotstocked.com/10-k/diasense-inc-DSNS-330060.html>,¹ most recently known as “Truewest,”² The story continues, and Jeremy Grata and Michael N Pitsakis (neither one had appeared as an inventor for Diasense or Biocontrol before),

¹ “Truewest Corporation was incorporated in the Commonwealth of Pennsylvania on July 5, 1989 as Diasense, Inc., (“Truewest”, or the “Company”) a wholly owned subsidiary of Biocontrol Technology, Inc., which later changed its name to BICO Inc. (BICO). BICO owned approximately 52% of Truewest until July 23, 2004 when BICO sold its entire ownership interest, 11,975,000 shares of common stock, to Dominion Assets, LLC. []

On August 16, 2006, the Company received two letters from Dominion Assets, LLC (“Dominion”), demanding immediate payment of principal and interest under, respectively, (i) that certain Demand Note, dated July 23, 2004, in a principal amount of \$1,954,936, issued by the Company to BICO, Inc. (“BICO”) and assigned by BICO to Dominion, as amended effective September 28, 2004 (the “Demand Note”), and (ii) the additional loans totaling \$50,700 in principal amount extended by Dominion to the Company under that certain Note and Security Agreement, dated October 29, 2004, by and between the Company and Dominion, as amended.

On August 29, 2006, the Company entered into a Voluntary Surrender Agreement (the “Voluntary Surrender Agreement”) with Dominion Assets, LLC (“Dominion”) whereby all of the Company’s assets, pledged as collateral to secure loan agreements under which the Company is in default, were repossessed. Dominion is the majority shareholder of the Company. Keith R. Keeling owns a majority 75% interest in Dominion and was also a former member of the Company’s Board of Directors and the former CEO of the Company until resigning from both such positions with the Company on August 4, 2006.”

² Truewest Corporation’s common stock [was] deleted from OTC Bulletin Board (OTCBB) effective September 18, 2013.

shortly after becoming consultants to Diasense¹, filed a patent application in 2006, with Diasense, Inc., as the assignee, based on a provisional patent they filed in 2005. Sometime later, the assignee became Dominion Assets of Potomac Falls, VA (see footnote). They obtained a patent in 2012, US 8,14,0139, based on that application. Dominion filed its own patent application in 2012, a continuation-in-part, which became US 9,037,206.

On May 30, 2012, just a few months before the latest filed Biocontrol patent expired, Dominion Assets sued Masimo and its subsidiary Cercacor for infringement of three of the patents they owned. Dominion had acquired the assets of Biocontrol and had decided to assert them. Interestingly, the suit was not about glucose (Cercacor, like everyone else, has not yet marketed a noninvasive glucose meter), but about measuring carboxyhemoglobin and methemoglobin in the near-infrared. It appears that this story is indeed not yet over.

A practice where companies buy up patents to use for leverage or bargaining chips in negotiations, has become more prevalent in recent years. Some companies who do this are termed “patent trolls,” but other terms include “patent holding company” (PHC) or “nonpracticing entity” (NPE), while some actually do so to continue the activities of the predecessor company. It illustrates another potential problem raised earlier—because so many thousands of patents have been issued in this area, they could all be used as threats or leverage against a startup company that might achieve success in noninvasive glucose measurement. Defending a patent infringement suit can cost millions of dollars, and small entities without corporate backing might not be able to afford the cost. Even a large corporate entity could see itself ensnarled in lawsuits if a product ever came on the market.

Some interesting facts were discovered during the progress of the lawsuit. Dominion, in an attempt to “monetize” its patents, had sold them to a third party and did not own them on the date the suit was filed. The Court dismissed the suit on Friday, June 27, 2014, but

¹ Each was granted warrants to purchase 4,000,000 shares of Diasense's restricted common stock at an exercise price of \$0.01 per share (<http://www.sec.gov/Archives/edgar/data/895650/0000895650-05-000019.txt>).

Dominion filed essentially the same suit again on Monday, June 30, with statements that they had recovered ownership of the patents.

Futrex—The Dream Beam¹: As alluded to above, there are some bad guys, some good guys, and some guys who just seem to have black clouds over their heads, not unlike the Li'l Abner character Joe Btfsplk. Robert Rosenthal,² who founded Futrex (and at least one other near-infrared company, the reverse-eponymous Trebor), seems to be one of the last group.



The device that Rosenthal touted for many years was a small, handheld meter into which a finger was inserted, and which used a number of LEDs with interference filters to examine tissue at various wavelengths in the near-infrared. Over the years, there were very public clinical trials to gather data, numerous premature announcements, followed by long silences as the technology was re-examined.

Following a private placement and an attempted initial public offering of stock, Rosenthal had his own problems with shareholders and the Securities and Exchange

¹ LifeScan, as well as the other major companies in the blood glucose area, closely followed the developments at Futrex. Bob and I made visits and held numerous discussions between 1989 and 1993, but they did not lead to a relationship between the two companies.

² Bob developed Type 2 diabetes while working on this project, and created what he called the “2JD” oral tolerance test, standing for “two jelly donuts.”

Commission. The following excerpt was published in *Medical Device and Diagnostic Industry Magazine* in March 1997:

“But amid the hopes for developing a painless glucose monitor are stories such as that of Futrex Medical Instrumentation, Inc. (Gaithersburg, MD). For years, the firm showcased its DreamBeam, a battery-operated box about the size of a television remote control designed to provide noninvasive glucose measurements with the use of infrared radiation. Last September, the Securities and Exchange Commission (SEC) filed a fraud action alleging that Futrex and its senior officer, Robert D. Rosenthal, made false claims to investors in connection with a \$1.85 million private placement of debt securities. The SEC alleges that the company and Rosenthal knowingly deceived investors, presenting false conclusions from clinical studies. During at least one meeting with investors, Rosenthal used the device on himself, and claimed the readings were accurate. But according to the SEC, he allegedly had ‘directed a Futrex employee to program a DreamBeam to function as if it were giving a glucose reading.’ Rosenthal was not available to MD&DI for comment.”

The issue was finally settled in 1999 with Rosenthal neither admitting nor denying the Commission’s allegations but agreeing to the entry of a judgment enjoining him from violating securities regulations and the payment of a civil penalty of \$50,000.

The Futrex website no longer contains any mention of blood glucose monitoring devices, focusing instead on near-infrared body fat meters. The FDA’s Consumer Magazine from Jan-Feb 2000 had the following statement:

“The president and chairman of the board of a medical device company based in Gaithersburg, Md., pleaded guilty early in 1999 to charges that his company imported and sold to hospitals and clinics a device for measuring body fat before FDA approved the device for marketing. Robert Rosenthal, head of Futrex Inc., was sentenced on April 29, 1999, by U.S. District Judge Deborah K. Chasanow to four months of home detention, 18 months of probation, a \$3,000 fine, and a \$200 special assessment fee. In addition to the sentence imposed by Judge Chasanow, Rosenthal was ordered to pay a \$90,000 fine to the U.S. Customs Service and a \$50,000 fine to the U.S. Securities and Exchange Commission (SEC) as a result of civil settlements with those agencies. [...] FDA never pursued Rosenthal on the noninvasive blood glucose monitor, the so-called Dream Beam, because he never attempted to market it in the United States.”

Rosenthal replied to the FDA (listed in the May-June 2000 FDA Consumer Newsletter, Letters to the Editor):

“Our company's most important new product is a non-invasive blood glucose meter, mentioned in the last paragraph of the article. It is currently undergoing clinical trials. Despite our belief that FDA has treated and is treating Futrex unfairly, for the sake of the 16 million Americans with diabetes, we pray that FDA will consider these clinical trials based on their scientific merits.”

As of 2017, there was still a Futrex [website](#) advertising body fat meters under the ownership of “Futrex Tech,” complete with testimonials from satisfied customers.

Kromoscopy: One of the stranger near-infrared-based approaches to glucose measurement came from the prolific mind of Myron Block, who was an inventor and early developer of interferometric spectrometers. Dr. Mark Arnold of the University of Iowa (himself a long-time researcher in the field of noninvasive glucose measurements using near-infrared spectroscopy), presented the following:

“Kromoscopy is a new measurement code for analytical science. In this method, white light passes through the sample and the transmitted light is divided into four separate detector channels. The response function of each channel is defined by the source, detector, and bandpass function of a filter that is positioned immediately before the detector. Each chemical species displays a unique Kromoscopic response when represented as a vector in the multidimensional space defined by the four detector signals.”

The approach uses the overlapping channels analogously to the red, green and blue cone visual pigments in the eye which allow people to distinguish thousands of separate colors. Unfortunately, although the system responds to glucose in water, there has never been a convincing demonstration that this approach holds significant promise for accurate tissue glucose measurement. An option to pursue the technology was secured by Inverness Medical prior to its acquisition by LifeScan, as were some rights to Dr. Arnold's traditional near-infrared technology.

Dr. Arnold's website contains the following, unusually honest assessment of his near-infrared approach:

“Recently, we have succeeded in measuring glucose noninvasively from human subjects by an analysis of spectra collected across tongues. Although measurement errors are too large for clinical purposes, these experimental results demonstrate the possibility of noninvasive blood glucose measurements”

SugarTrac: In 1997, LifeScan was approached by Richard Peters, a principal of Emerging Technology Systems, Ltd. in Akron, Ohio who had developed the “SugarTrac” Noninvasive meter. His company, later renamed LifeTrac Systems, Inc., as of 2015 had no website. The technology was fairly simple, consisting of a single 940 nm near-infrared LED (similar to those used in a television remote control) and a photodetector placed across the earlobe from each other. Using a combination of the pulsatile component of blood flow and some mathematical algorithms, a glucose result could be generated in as little as 30 seconds.



Accompanying the presentation was an impressive list of blood glucose results obtained using both their instrument and a traditional blood glucose meter. The results agreed very well, and LifeScan paid them \$1,000,000 for the rights to the technology for the next three months. After looking over the technology,¹ LifeScan scientists organized a repeat of the comparison between the device and a traditional meter (with about 50 diabetic patients), with the exception that the test results from the SugarTrac were obtained first,

¹ By this time, LifeScan had many years of experience with near-infrared attempts to measure blood glucose, with at least five different companies. Since they had seen multiple failures for NIR devices using dozens of wavelengths, the technical people were convinced that no accurate measurement of glucose could be made in tissue at a single NIR wavelength. The business representatives, however, were swayed by the close agreement in the list of results and were unwilling to let another company have access to the technology until the evaluation was completed.

written down, and the reference measurement made out of the sight and hearing of the company representatives. Not surprisingly, the correlation between the two sets of results was no better than chance—in the first trial that they used to get funding, they had measured each patient with the reference meter first, then continued to measure with their device until they finally got good agreement.

Other players: Many other groups have explored the near-infrared approach, and to date, none has achieved clinical or commercial success. It remains the single most active area of noninvasive glucose research.

Other Approaches

Transdermal Measurements

Cygnus: Another noninvasive technology, developed at the University of California, San Francisco and Cygnus Therapeutic Corporation in Redwood City, CA, had nothing to do with light. Rather, the approach measured sugar levels transdermally with a device called a GlucoWatch. The process, called reverse iontophoresis, used an electric current to extract glucose molecules out of the body. Originally, this electrotransport technology was developed to deliver drugs transdermally *into* tissue by enlarging the pores to allow larger drug molecules to pass through. The noninvasive monitor included a sensing pad termed a GlucoPad that adhered to the skin. It was placed on the back of the GlucoWatch to measure and read glucose levels electrochemically. Cygnus envisioned that the pad would be replaced daily (with a recalibration each day based on a finger stick result), but during each day, the watch would allow for continuous monitoring of glucose levels. It was the only device broadly described as “noninvasive” to be approved by the FDA but only for supplemental use in combination with another conventional glucose monitor—termed “adjunctive” use.



In 2001, headlines like the following appeared: “Washington — Diabetics are about to get a science fiction-like way to measure their blood sugar painlessly: The government approved a wristwatch-looking device Thursday that uses tiny electric currents to monitor diabetes.” The reality of the device was quite a bit different from the advance press. The amount of current required to pull glucose out of the skin was enough to cause reddening and burning of the skin (sometimes even blisters), and the accuracy was not good enough to allow it to be used reliably, even as an alarm for low glucose values. The product is no longer manufactured, the company went bankrupt, and its assets were eventually sold for \$10 million to [Animas](#), an insulin pump company that had abandoned its own glucose monitoring system (an implanted optical sensor that tried to measure glucose with source and sensors that surrounded blood vessel) a few years before. Animas was itself bought by Johnson & Johnson in 2005.

The New Gluowatch. But nothing in this field is ever gone for good. In December of 2012, a patent application was published (U.S 2012/0323097¹ to Chowdhury of [Nemauro Pharma](#) of Leicestershire, UK), describing what the company calls “Continuous Glucose Monitoring Watch (“Gluowatch”). This version is also based on reverse iontophoresis, but adds mechanical vibration to flex the “patch” and enhance permeation, and, according to company publications, may measure the ratio of sodium ions extracted along with the glucose.

¹ In December of 2016, the application went abandoned in the USPTO due to failure to respond to an office action.



No data have yet been reported outside the normal glucose range, and realistic concerns should be raised about the device's performance at low and high levels. In hypoglycemia, sweating is common, and could influence the concentration of glucose.

In October of 2015, Nemaura announced that their renamed sugarBEAT® CGM System had completed an “interim clinical trial” (not registered with clinicaltrials.org) involving 19 patients, using the system for 12 hours a day for four days each, with a MARD of less than 11.8%. In March of 2016 Nemaura announced that it had received notification of CE Approval, however, the device for which CE grant notice was granted used “retrospective evaluation” of the glucose data, which is generally not considered a valid test, and would not be accepted by the FDA. Time will tell if its performance actually exceeds that of the original GlucoWatch.

Tattoos

As an alternative, a transdermal glucose measurement represented as a “temporary tattoo” received widespread coverage, based on an article [“Tattoo-Based Noninvasive Glucose Monitoring: A Proof-of-Concept Study,”](#) Amay J. Bhandarkar. Et al., Anal. Chem. 2015, 87, 394–398, and described as a “flexible, low-cost, and aesthetically pleasing iontophoretic-biosensing tattoo platform.” Like GlucoWatch, this approach also uses reverse iontophoresis, but curiously, in-vivo data reported as being available for two subjects were not included in the article. The authors state “Plot depicting blood glucose

levels measured for two subjects before and after meal consumption. This material is available free of charge via the Internet at <http://pubs.acs.org>,” but no reference is given that allows retrieval of that information. The authors contend that a reduced current density below that used by the GlucoWatch will prevent the skin damage reported for that device. We will await publication of results to determine if this has been achieved, and if the other reported problems of the GlucoWatch have been overcome.

The company resulting from this effort was originally “Electrozyme;” now “[Biolinq](#),” and Prof. Joseph Wang is the “Technology Innovator” in a YouTube [video](#) showing the fabrication of the tattoos.

Gerard Coté at Texas A&M University (who has largely focused on measuring glucose by optical rotation in the eye), has also worked to develop a [fluorescent tattoo](#) which changes the intensity or color of emitted light with variations in glucose.

GluCall. Internet announcements for this product from Korea Medical Holdings began to appear in about 2007 and persist today, saying now, as then, “Thus [GluCall](#) will be a breakthrough in medical arena particularly in diabetes area. It eventually promotes diabetic patient's quality of life,” and appears from the description in a [review article](#) to be based on reverse iontophoresis. It does have a wristwatch readout device, however.



Pulse Oximetry Related Measurements

Because this technique has become so successful and ubiquitous for blood oxygenation measurements, a number of groups have investigated whether it might be extended to glucose. Yitzhak Mendelson, one of the originators of pulse oximetry, was also a founder

of VivaScan. After exploring the suitability, his company chose to pursue the “bridge-squeeze” technique described above. Nellcor, one of the early market leaders in pulse oximetry, also has issued patents in this area—see, for example, US6,845,256.

Others (Philips, above), have explored the relationship between carbon monoxide in breath and glucose, based in part on pulse oximetry measurements. A company called 3 Wave Optics in Massachusetts had a patent application from 2005 which never matured into an issued patent, and Masimo, which has substantial involvement in the pulse oximetry business, has had an in-house noninvasive glucose effort for at least twenty years (originally at “Masimo Laboratories,” now renamed Cercacor), but there has been no report of success for glucose there, either.

Pulse Wave

Because the pulse wave is easily analyzed, it has appeared to several inventors that it might contain glucose information outside of normal pulse oximetry measurements (it is sometimes referred to as “PPG,” short for photoplethysmography). The desire for “wearable” health monitors to include blood pressure measurements has provided additional effort to utilize this source of information. But as easy as it is to make PPG-based measurements related to hemoglobin, it is much harder to make any measurement of glucose from that signal. As mentioned, the much more strongly-colored hemoglobin molecules live only in the blood vessels and whose size and contents vary strongly with the pulse, while glucose, which has essentially no color, is present in every body fluid and does not respond significantly to the pulse waveform. A number of companies touting such devices have had to retract early promises that they could monitor blood glucose this way.

BioSign, a company in Toronto, Ontario, has promoted its UFIT device for glucose measurements, even promising delivery in Europe in late 2011. It used an “optical probe beam¹” to derive blood glucose information at the same time it monitors blood pressure and pulse rate. A 2007 press release claimed that a study of 120 people was intended to

¹ U.S. Patent application 20080249387. The technology for measuring glucose is not further described, and patent office records indicate that the application was abandoned in 2013.

show “that the arterial pulse, a rich source of clinically relevant information (e.g., rate, rhythm, pattern, pressure and oxygen), could also provide information on blood glucose,” and demonstrated “a tight statistical correlation (0.998, Pearson substantial equivalence) between UFIT® and laboratory analysis of blood glucose, with a low (1.63%) average of the mean percent difference between the UFIT® measurements and the laboratory analysis.” The correlation was obtained “post-hoc” (i.e., retrospectively) by “comparing a feature extracted from the radial artery pulse with laboratory blood glucose data.” As described above, a retrospective correlation can be obtained between blood glucose and most physiological parameters, however, it is not possible to show a correlation better than the error in the reference measurement, which is usually on the order of 4-5%. As of 2015, there is no mention of glucose on the company website.

A company known as Wor(l)d Media and Technology Corp (sometimes known by its stock symbol, WRMT) introduced a PPG-based product in 2017 with this headline: “Launch Of World's First Wearable, Non-Invasive, Continuous, Blood Glucose Estimation Technology Using WRMT's Smart Wristband, Helo, Will Generate Recurring Revenues For WRMT.” Their [announcement](#) said “Helo is not a medical device, but continuous measurement of blood glucose estimates are expected to be helpful in understanding blood glucose changes over time,” and further, that:

“WRMT's blood glucose estimation service is non-invasive, and can be scheduled to record blood glucose estimates routinely with readings stored in Helo's LifeLog for easy presentation to the diabetic's health care provider. In the event that Helo detects a blood glucose problem, Helo's Guardian service will automatically alert the wearer and their care giver. It is expected that this service will initially be available in Q4'17, to all Helo wearers who opt-in for the service and who pay the initial fee to cover registration and to start blood glucose monitoring.”



It will be interesting to see if a product with the ability to provide “blood glucose estimates,” which also claims to provide “blood glucose monitoring” at extra charge will not be viewed by FDA as a medical device.

A substantial number of other patents have been issued for extracting glucose levels from a range of pulse information, but curiously, one (US 6,968,221) was issued to Robert Rosenthal (of Futrex infamy, above) in 2005, describing a method of deriving blood glucose information from an optical pulse wave. More recently, Sabirmedical, a Spanish company, has reported that it is investigating the technique for glucose measurement, and has European patent application EP2544124 A1. A patent application (US 2015/0031969 to Khair) has suggested that waveforms derived from either pulse oximetry or ECG tracings, especially the “dicrotic notch” might include glucose information, but is short on actual methods for calculation.

The ease of accessing this waveform has led to a number of “wearable” or “watch” designs for noninvasive glucose measurement, such as the InfraV from the Infravitals Company that claims “constant monitoring of blood sugar,” with an [Indiegogo](#) crowdfunding campaign promising delivery of a working device in exchange for a funding contribution. The campaign has been more successful than others mentioned earlier.

St. Louis Medical Devices, Inc.

Four closely-related patent applications in this area have issued by Zhi Xu, Associate Professor of chemistry and biochemistry at the University of Missouri—St. Louis (and new entrepreneur at St. Louis Medical Devices., which has licensed the technology): US20130006070, 71, 72 and 73. It is based on extraction of glucose information from a fingertip pulse wave in the near-infrared (800 to 1600 nm.), using Partial Least Squares (PLS) regression. With the hubris of the newly-arrived to this field, he stated “There have been 25 years of attempts to create such a non-invasive glucose monitor. I think we’ve done it.” In May of 2011, the St. Lois Post-Dispatch reported: Tamara Wilgers, UMSL's director of technology commercialization said “We are really sure this is it. We don't have clinical data as proof, but we believe it is.” George Chen, CEO of St. Louis Medical Devices, said he hopes the company will be ready to request approval from the U.S. Food

and Drug Administration in “two years.” His best-case scenario has the device for sale in four years, priced between \$500 and \$800. UMSL’s Zhi Xu was named 2014 “Inventor of the Year” by The Bar Association of Metropolitan St. Louis. A 2011 Article on the company from the St. Louis Post-Dispatch was titled “Developing new glucose test is high-stakes, slow-going pursuit.” So it goes.

Nuclear Magnetic Resonance (or MRI)

U.S. Patent 5,685,300 was issued in 1997 that claimed noninvasive measurement of glucose using NMR techniques but which only showed how glucose in blood samples could be measured. The inventor speculated that by using an MRI instrument, time slices could be made at different parts of the heartbeat, and the difference in blood content of the image might be used to measure glucose. This probably marks the single most expensive (and possibly most unrealistic) approach yet proposed for noninvasive glucose measurement.

Microwave Spectroscopy

In addition to the entry below about Solid State Farms/Pindi Products, Dr. Randall Jean of Baylor University created a stir in 2008 with the [publication](#) of a paper describing a glucose sensor based on microwave pulses¹, but no update on its progress has appeared since.

A publication available for download by searching the Internet for the title “Microwave Power Absorption in Human Body for Non-invasive Glucose Monitoring” (Progress In Electromagnetics Research Symposium Proceedings, Stockholm, Sweden, Aug. 12-15, 2013 109) concludes with the warning that “contributions of both real and imaginery [sic] components of complex permittivity should be considered when conducting or modelling dielectric NGM measurements.”

¹ Jean, B.R., Green, E.C., and McClung, M.J., “A Microwave Frequency Sensor for Non-Invasive Blood-Glucose Measurement,” IEEE Sensors Applications Symposium, Atlanta, GA, February 12-14, 2008

Another patent application, US 2012/0150000, issued to three people in Liverpool, Great Britain, also described the use of microwaves for glucose measurement. According to patent office records, it is now “abandoned -- failure to respond to an office action.” It seemed to work well, though, on solutions of “0-100% glucose concentration.”

Subdermal

At least the following companies have investigated the use of a “reporter molecule,” placed just under the skin, which is sensitive to glucose and reports the concentration by changing color or varying its fluorescence: Sensor Technologies, Sensors for Medicine and Science (“S4MS”), BioPeak, MiniMed, Glumetrics, Becton-Dickinson, Precisense, Motorola and Argose. The idea sounds great—just a tattoo or minor injection of a substance under the skin, then a sensing device can read the amount of glucose by shining light through the skin and measuring the response.

The practical complications are similar to those that have plagued investigators who have tried to develop long-lived, in-dwelling sensors—anything inserted into the body that is not rejected by the immune system (an “immunogenic response”) will be incorporated by the organism surrounding it with a coating of protein (the “foreign body response”) that creates two problems for glucose measurement. It can either reduce the access of glucose to the sensing material (which will increase the response time to changes in glucose, or reduce the concentration of glucose that the sensor “sees”), or it can decrease the amount of light that passes into it or is transmitted back out of the reporter. In every case so far, the result has been that the lifetime of the material in the body is limited, and the accuracy degrades over a fairly short period. And when a “noninvasive” measurement device requires frequent recalibration using an invasive device, it quickly loses its appeal to the user. A further complication is introduced by the variable reflectance of skin, requiring precise alignment between a reader and the skin area to be read. Although it’s easy to underestimate them during the early, enthusiastic years, the practical complications of a requirement like this need to be considered when assessing how well patients would be able to use a device in the home.

A more recent approach has been proposed by a German company called [Eyesense](#) (not to be confused with iSense in Portland, OR, or with i-SENS in Korea) utilizing a reporter molecule inserted under the conjunctiva on the surface of the eye and measured with a hand-held external photometer. It is not known if trying to measure glucose at this location will suffer the same drawbacks as at other places in the body, and there could be some lack of patient acceptance because of the location. Recently, the company has branched out to include an implanted continuous sensor (possibly using the same reporter molecule as in the conjunctival sensor, and may have abandoned implantation in the eye). “The sensor material is located in the tip of an optical fiber. The fiber is placed at a defined depth under the skin and fixed there. Excitation and detection is done with miniaturized optics. The optics housing is fixed to the skin with a long-term biocompatible plaster.” In 2013, they had reported measurement accuracy of up to 14 days.

The company Sensors for Medicine and Science (“S4MS”) (which set a record by renaming itself twice in two years, first to “Sensors for Medicine and Science Inc. (SMSI) and then to “[Senseonics](#)”) mentioned above, has disclosed a notably different approach to the use of an implanted device. It’s a three-part system (now named “Eversense”), with the sensor (left), the transmitter (center) and the smart phone display (right). The implanted sensor--just “a little larger” than a grain of rice--is powered by an externally driven 13.56 MHz inductive link from the transmitter, allowing it to operate without a battery. The implanted receiver then illuminates a fluorescent sensor that is sensitive to the glucose that has diffused to the sensor from the surrounding interstitial fluid, and the response is sent back to the transmitter for display on the smart phone screen. The company received a substantial \$54.1 million Series D equity financing led by Delphi Ventures in 2011, underwent a “reverse acquisition” with a company named ASN Technologies, then was granted a CE mark in June of 2016, based on data showing consistent results for three months of use. They have reportedly partnered with Roche Diabetes for distribution of the system across Europe, the Middle East, and Africa.

The real challenge here, as with all implanted devices, is the lifetime of the sensor. It has been speculated that monthly recalibration for a noninvasive device would make it

commercially successful, but with a device implanted under the skin (that needs to be explanted and replaced when it no longer provides accurate results), the pivotal replacement interval is probably between six months and one year, and their success will probably be driven by how effective their “anti-fouling” coating technology turns out to be. If Senseonics can realize this replacement interval, they could be close enough to a continuous “noninvasive” monitor to achieve success. There will always be the stigma of a sizable needle to implant the device (even under local anesthetic), and that will likely limit market acceptance to some degree.



Radio Frequency/Impedance

Possibly because it seems mysterious, or because it also seems extremely scientific, impedance measurements using radio frequency (or other frequency ranges) have appeared occasionally over the years. One group in Switzerland, Pendragon,



made a big splash and presented several posters at scientific meetings (with some well-known researchers in the field publishing papers) before folding when the technique was shown not to provide reproducible results. Some of the principals of Pendragon founded a second company, based on the same approach, called [Solianis](#), and it appears to have met the same fate. Its assets were bought in 2011 by a third Swiss Company called [Biovotion](#), and U.S. Patent 9,247,905, assigned to Biovotion, and based on the same principles of

impedance measurement issued in 2016 to many of the same principals. Most recently, US 9,526,431, titled “System for noninvasive optical measurements of physiological properties in tissue,” indicated a new direction for the group to include optical measurements with impedance measurements, possibly another case of “making the hammer heavier.”

Another similar approach is the Glucoband was touted as being developed by Calisto Medical. It uses “bio-electromagnetic resonance phenomenon” (a previously unknown effect) and again would be in the form of a wristwatch, had it come to reality. The Calisto website described the technology:

Bio-Electromagnetic Resonance (BEMR™) technology is based on the detection of a change of electrical impedance in the human body caused by an externally applied glucose-specific electromagnetic wave ('glucose signature').

Three known Phenomena are utilized in the Glucoband:

- Each concentration of Glucose solution has its unique electromagnetic molecular self-oscillation signature-wave - 'glucose signature'
- Human body is experiencing BEMR when a signature-wave matching any internal molecular self-oscillation wave is applied
- Due to the BEMR, the body is changing its electrical impedance



The company apparently ceased to exist around 2006.

Another player using impedance measurements (possibly not radio-frequency) is GlucoSense in Boston, MA (not related to Glucosense in England). Their proposed device used an arm sensor (but could probably be made into a wristwatch if the technology were to succeed). The company seemed to no longer exist as of 2013.

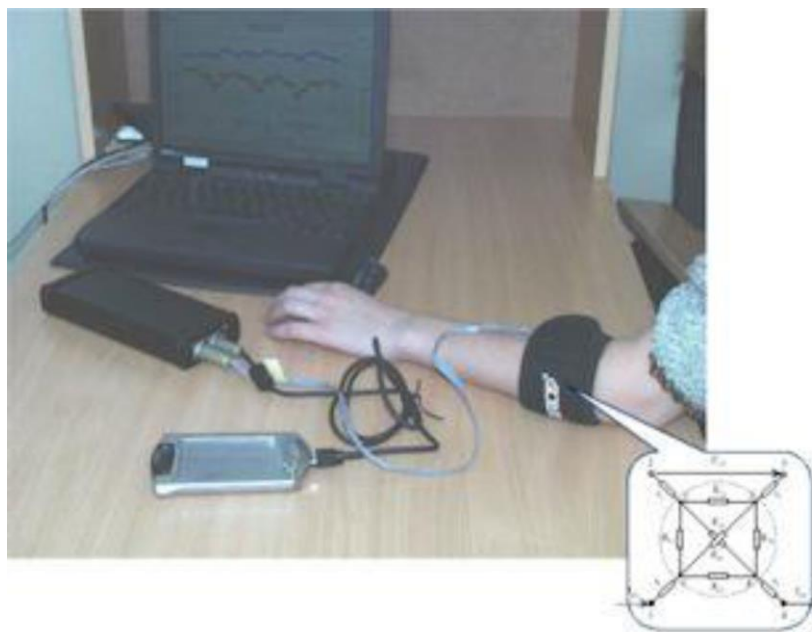

A possibly related company is Gen3 Partners (<http://www.gen3partners.com/>), with a publication ([International Journal of Biomedical Engineering and Technology 2012 - Vol. 8, No.1 pp. 60 - 81](#)) and two patents: US 6,998,428 and 6,841,389. While the first patent is assigned to Gen3, the other is assigned to Glucosense, and the work may have been done for them on a contract basis. The same picture that appeared on the Glucosense website was shown in their earlier promotional material.

“BIG,” or Bio-Impedance General Ltd., is a company located in Ramat Gan, Israel. Judging by the name, it uses an impedance measurement, but no technical details are available from the website, and there is no mention of glucose there in 2013. The former CEO of BIG is Gadi Kan-Tor, now heading up a company called Night Sense, developing a noninvasive method for detection of hypoglycemia.

A new entrant in this field is Azurite, a startup founded by Laura Andrews to help her sister who has type 1 diabetes. It appears to use an impedance measurement (described as “unique electromagnetic (EM) sensing system that measures intrinsic properties of the glucose molecule in the blood”) and has a campaign on another crowd-funding site (<https://experiment.com/projects/can-we-noninvasively-measure-blood-sugar-for->

[diabetes](#)), where it raised 102% of its initial \$7,500 funding goal.

Yet another company, called [Mediwise](#), has communicated about the “[Glucowise](#)” noninvasive sensor on their website <http://www.gluco-wise.com/>. The device “extracts” glucose levels “by a non-invasive technique which transmits low-power radio waves through a section of the human body, such as the area between the thumb and forefinger or the earlobe.” The website indicates that the frequency range used is about 65 GHz, (with a wavelength of about 4.6 millimeters, or about 0.2 inches) but there is no information about the expected mechanism of interaction with glucose at that frequency, except the statement that “These waves are large enough to allow penetration through the tissue, yet simultaneously small enough to provide sufficient resolution of the blood regions inside the tissue.” They also used to say they expect to begin taking “pre-orders” in late 2016, but recently changed that date to 2018.



The parent company is apparently related to another called [Lamda Guard Technologies](#) (the same CEO and CTO), which claims expertise in “metamaterials” (materials engineered to have properties that have not yet been found in nature, such as Harry Potter’s invisibility cloak), including transparent coatings for visors that block laser light for pilot safety, and it is apparently these same metamaterials “which temporarily make the skin transparent to the radio waves when a measurement is initiated.” It is not possible to tell, in 2017, if this is a naive intent to add to the capabilities of such materials, or if some actual glucose measurements have been made.

Another recent entrant in this field, with a technology described as “Radio frequency (RF) spread spectrum identification and quantization of glucose” is Jupiter Devices,

located in Portland, OR. Their [website](#) indicates they have already measured glucose *in vitro* from 40-400 mg/dl.

A company that has created a major controversy in this general field is [Healbe](#), with their heavily promoted “Gobe” noninvasive glucose monitor and calorie tracker. They registered on the crowd-funding site Indiegogo, requesting \$100,000, but raised over \$1,000,000. The website claims that the device can not only measure glucose values, but also calorie intake and calories burned. Their [Indiegogo site](#), which is clearly a public relations (or hype) masterpiece, includes incentives for contributions ranging from getting a meter with a value of \$299.99 for just a \$209 contribution (which was accepted by 267 donors) to a \$16,000 donation, which would bring the lucky donor:

<p style="text-align: center;">“Be Our Guest</p> <p style="text-align: center;">\$16000</p> <p>Enjoy a trip to St. Petersburg, Russia, for two. Includes airfare and hotel for four nights. Spend two days with Healbe™ designers and engineers, and enjoy a celebration dinner in your honor; plus get two Healbe GoBe™ Original 100% Automatic Body Managers™.</p> <p>0 out of 1 claimed</p> <p>Estimated delivery: June 2014”</p>

It appears that this opportunity went unclaimed.

On [Pando](#) (<http://pando.com/>, [search for Healbe]) an admittedly comic-art-heavy website which says “We have one goal here at PandoDaily: To be the site-of-record for that startup root-system and everything that springs up from it, cycle-after-cycle,” Paul Carr has written a devastating series of reviews of Healbe and its Indiegogo campaign. A typical title is “Healbe Hustle_ The full story of how a failed Russian cake shop owner humiliated Indiegogo and took “the crowd” for over \$1m _ PandoDaily.” In an interview, Healbe said they chose Indiegogo over Kickstarter, because the latter had more restrictive criteria for inclusion of a funding campaign. It is not clear that any devices have yet been shipped, or how much of the Indiegogo donations have been returned.

One accessible patent application that describes the technology, US20150073242, titled “Method for Determining Glucose Concentration in Human Blood” issued to people with Russian names but assigned to Healbe with an address in Redwood City, Ca, claims to measure changes in the amount of extracellular (interstitial fluid and plasmas) by measuring impedance at two different frequencies.

The Indiegogo page adds this slick graphic, headlined “How does Healbe GoBe™ work?”

The Unsurpassed Accuracy of Healbe FLOW™ Technology

Only FLOW Technology measures calorie intake through your skin.

Unlike apps and wearable devices that require you to manually log the calories you consume, only GoBe gives you 100% automatic calorie management with FLOW Technology, the patented innovation that combines information from three sensors with an advanced algorithm.

- Pressure Sensor** measures blood flow and heart rate
- Impedance Sensor** measures fluid levels in tissue
- Accelerometer** measures body movement and activity

BELIEVE IT WITH FLOW PATENTED TECHNOLOGY

- Calorie Intake
- Calories Burned
- Heart Rate
- Stress Levels
- Hydration Levels
- Sleep Status

Tell It Nothing. Know Everything. GoBe You.

Time (and potential litigation) will determine if any of this is true.

Magnetics

No list of candidate technologies would be complete without including magnetism to detect variations in glucose levels. [Micromem Applied Sensor Technologies](#) (MAST; New York), a subsidiary of Micromem Technologies (Toronto), a company with experience in magnetoresistive random-access memory chips, is hoping to transfer what it learned in mining exploration “to noninvasively ‘see’ glucose levels under the skin, enabling diabetics to continuously monitor blood sugar with a device that will look like a wristwatch.” As of 2015, they seem to have moved on toward “power line monitoring and energy storage.”

Microporation

SpectRx, headquartered in Norcross, Georgia, began life as Laser Atlanta, and had been interested in noninvasive glucose measurements for at least fifteen years. Their first approach, which was licensed for a time to Boehringer Mannheim (now Roche diagnostics), involved measuring the amount of crosslinking in the lens of the eye. This process is a consequence of both aging and diabetes, and they initially thought it might be reversible enough to track glucose levels. Studies showed that it was essentially irreversible, and could not respond to even weekly changes in glucose levels, let alone those occurring in just a few minutes.¹

They moved on to a system they termed “microporation,” and their website showed a “Flash” animation of how it might work: a laser beam creates very small holes in the skin, through which interstitial fluid can be collected and analyzed for glucose with an electrochemical sensor. It is touted as a “continuous” monitor, but the need to find new sites to create the holes would not allow continuous monitoring at one site for very long.

¹ SpectRx developed a device called “BiliChek” which noninvasively monitors bilirubin in the skin, especially in babies with jaundice. Bilirubin (a breakdown product of hemoglobin) can be measured through the skin because of its intense yellow-green color. The BiliChek now appears to be owned by Philips Respironics.

In practice, a dye which absorbs near-infrared light is applied to the skin, and a laser burns off the top layer of skin.¹ Abbott invested in the technology for a year or two, but apparently decided it was not a practical approach.

A patent issued in 2006 (US 7,133,717) to Johnson & Johnson consumer product employees, describing an “electroporation” technique, but appeared not to go any further.

[Clintech](#) uses a similar microporation technique, but burns through the surface of the skin with a small microelectronic circuit. Their patents are jointly assigned to Medina ISF Equity LLC in New York, and Touchtek Labs LLC in Maryland but Clintech lists Carson City and Cambridge, UK [addresses](#). They describe both electrochemical glucose detection and “nanowires” that respond to other biomarkers by a change in conductivity. It is expected that these “micropores,” like SpectRx’s will allow a small amount of ISF to be analyzed, but should seal up quickly and are less likely to open up a second time, and there’s a strong chance of changing the composition of the ISF where the top layer of skin is burned through.

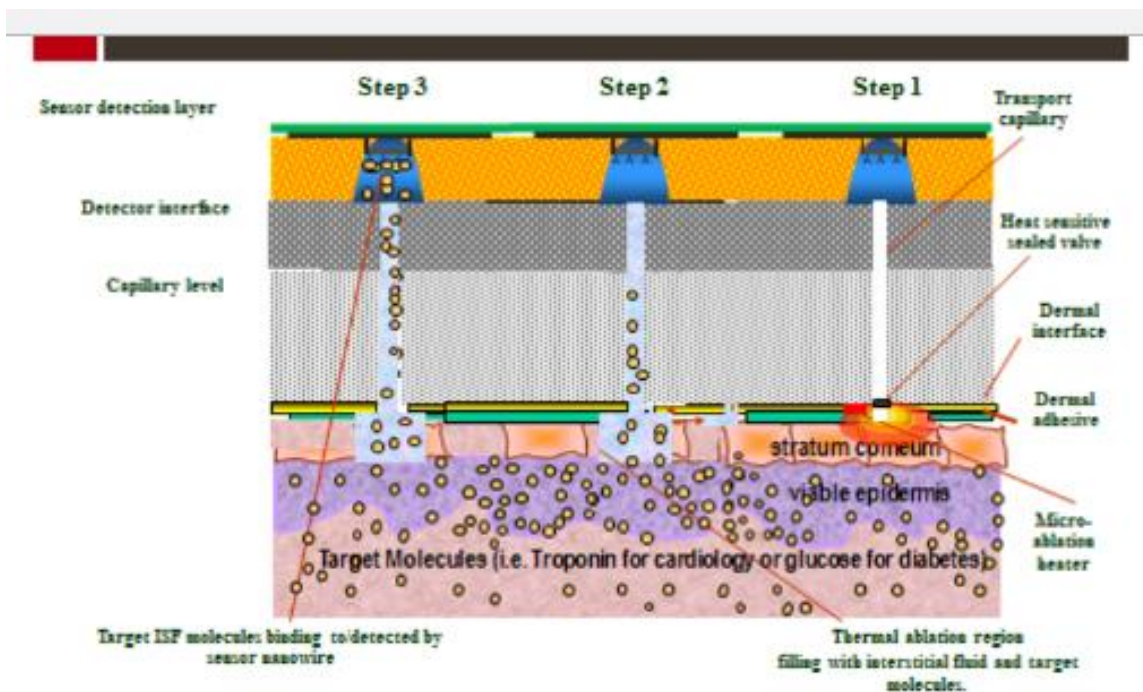

¹ When I visited their laboratories to see the test first-hand in about 1996, the most memorable part was the thin wisp of smoke that rose up from the site of the “microporation.” Three of us were in attendance, and the test failed to yield enough fluid to test any of us.

Optical Coherence Tomography

This powerful imaging technique, which allows investigators to effectively see optical images of tissue structures several millimeters below the surface of opaque tissue, was reported as a noninvasive technique by [Motamedi](#) and coworkers at the University of Texas Medical Branch in Galveston. It operates by measuring changes in the scattering of light, usually near-infrared wavelengths, as a function of depth.

It was extensively explored by GlucoLight in Bethlehem, PA, under a license agreement from the University of Texas. A number of intriguing patents and publications appeared with descriptions of how the technique could allow determination of glucose by detecting changes in the scattering coefficient of tissue at varying depths. It was speculated in one [publication](#) that the observed changes in scattering were the result of glucose molecules reversibly attaching to tissue proteins the same way they attach to hemoglobin and other proteins in blood. This approach seemed to hold great promise, not only for measuring glucose but also for its ability to elucidate some of the fundamental limitations encountered by near-infrared spectroscopy, but the company became a victim to the funding “drought” that accompanied the 2008 recession and has passed from existence.¹ GlucoLight patents are now owned by GLT Acquisition Corp, in Irvine, CA, the same company that also owns patents formerly issued to Sensys.

A second group, Newton Photonics, had a patent application published in 2007 using the same basic OCT technology as GlucoLight, except that it used a variety of temperatures to tease out variations in scattering coefficients from various depths of tissue. The application issued in 2011 as U.S. Patent 8,078,244, but the website had disappeared as of 2017.

¹ The principals of GlucoLight demonstrated a notable exception to the culture of secrecy that surrounds most noninvasive investigations. When I was hired by a potential investor to evaluate the technology, Matt Schurman and Ray Krauss (two principals in the company) shipped me a prototype instrument for evaluation, flew to California to meet with me, and disclosed the technology in unusually candid terms, even discussing potential problems and disadvantages.

Yet another group, Compact Imaging (formerly FP Technology) in Mountain View, California, has obtained a number of patents over the years, many issued to the founder and CTO, Josh Hogan. They have a technology called MRO™ (for “multiple reference OCT”) which they say is “a miniature form of OCT that at volume is projected to be comparable in size and cost to the optical pick-up unit in a DVD drive” and could potentially allow a miniaturized OCT apparatus small enough and with low enough power requirements to produce a consumer glucose meter based on this technology.

Gases emanating from the skin—a company called Better Life Technologies communicated a previously unknown approach to noninvasive glucose measurement. George McKinney, president/CEO, said. “We believe that we are on the verge of a great breakthrough with a novel approach to glucose monitoring focusing on analyzing gases emanating from the skin.” His Indiegogo [campaign](#) for a “Wireless Wearable Non-invasive Glucose Monitor--A better way to monitor diabetes and cancer in children and adults” had raised \$160 of the \$50,000 goal in early 2017. A MedStartr [campaign](#) for the same device has not done as well.

Teeth—One of the more surprising discoveries in this field is that teeth are relatively transparent in the near-infrared. A U.S. patent application (US 2015/0305658 A1), which claims priority to a US provisional patent application Serial No. 61/ 747,472, (which does not appear to yet have a corresponding US utility patent application), states “By shining light through the teeth, which have fewer spectral artifacts than skin in the near- infrared, the blood constituents may be measured with less interfering artifacts.” It includes the figure below, but does not indicate that any actual glucose measurements were made. The “pulp” inside teeth is reported to be extensively vascularized, with high rates of blood flow and high blood pressure.

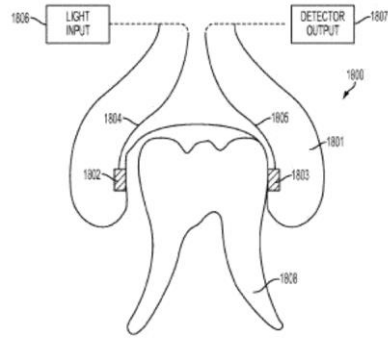

FIG. 18A

Another tooth-based measurement system (WO 2015/176004 A1) takes advantage of a dental crown to attach sensors for measurement of pH, glucose, and various chemicals found in saliva.

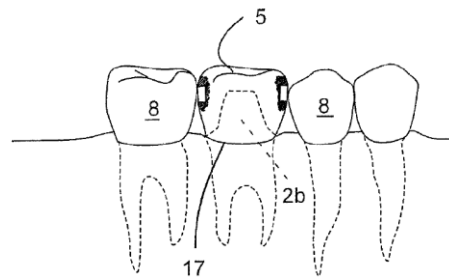
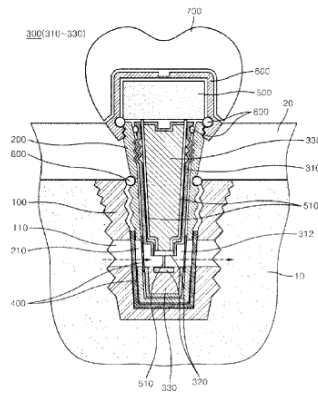

Fig. 2b

Yet another patent application (US 20170049393) describes a sensor as “noninvasive,” but requires implantation in bone, in the form of a tooth implant.

[Figure 1]



Green-turquoise Light: A patent bearing PCT designation WO 2016/027202 A2 assigned to Biolab Technologies, Ltd. In Jerusalem, proposes that glucose may be measured in tissue by its absorption of “green-turquoise light” of 490 to 505 nm, but no details of the absorption mechanism are provided.

Volume Detection—A patent application from the University of Illinois (US 2016/0252505) utilizes a hydrogel the volume of which changes on contact with glucose. The expansion of the gel can be detected either optically or electronically. A similar approach has been used by a Norwegian company named [Glucoset](#) for intravascular glucose measurements.

Thermal and “Combination” Techniques

In addition to OptiScan, where the temperature of tissue was manipulated by an early prototype in an attempt to cause variation in the optical emission of glucose in the infrared, in which glucose is determined by measuring the temperature of the fingertip, supposedly as a result of variation in metabolic activity with varying glucose levels. The first to appear indicated that the fingertip temperature would be a good indication of glucose; the most recent (U.S. Patent 6954661) has the following statement:

“Blood sugar levels are measured non-invasively based on temperature measurement. Measured blood sugar levels are corrected using blood oxygen saturation and blood flow volume. The measurement data is further stabilized by taking into consideration the influences of interfering substances on blood oxygen saturation.”

An example of another thermal approach used two locations near the ear to determine short-term trends in glucose, is U.S. Patent 6,949,070, issued in 2005 to Larry Ishler of Erie, PA, (whose son was reportedly diagnosed with Type 1 diabetes in college about ten years earlier) with a company called LWI & Associates, but there were no follow-ups. A patent, U.S. 7,729,734 for a combination of measurements, creatively termed “biothermophotonic,” issued in to Mandelis, *et al.* 2010, but the name was revised for a second patent to the same inventors in 2013, US 8,452,360, to a “photothermal radiometric” measurement.

Temperature—one patent application has appeared (US 2015/0297123) seeking to measure glucose from the temperature difference recorded in insulin dependent and non-insulin independent tissues of the body. Suggested examples of such tissues are “(oral mucosa, skin eyeball, etc.) and non-insulin dependent organs (fundus lens, retina adjacent to retinal tissue of the vitreous body).”

A patent application for a method using short bursts of ultrasound was filed by Joseph Frattarola in 2003, but never matured into an issued patent, and a second application, US 2016/0374599, published in late 2016, shortly after the obituary for the inventor.

U.S. Patent 8,315,681 issued in late 2012, assigned to Toshiba Medical and describing a temperature-modifying system attached to skin for glucose measurement. It includes Omar Khalil, a long-time veteran of many noninvasive glucose investigations, among the inventors.

It is typical of these investigations that, as good results are hard to produce by the initial approach, additional corrective measurements are added to remove interferences. This familiar process was defined by one investor, a retired venture capitalist and a veteran of many noninvasive glucose quests, as the process of “making the hammer heavier.”



A company that has had the most success with this “combination of ingredients” approach is [Integrity Applications](#), of Ashkelon, Israel. The company’s first issued U.S. patent, 6,954,662, states that the approach uses ultrasonic, conductivity and heat capacity sensors in an earlobe clip to noninvasively measure glucose levels in the blood (the patent cites both the Ishler thermal and the Frattarola ultrasound references above). Poster

presentations have been made annually at diabetes conferences, with those through 2007 listing the three technologies above. Beginning in posters in 2008 and with a later-issued patent (US 8,235,897) the conductivity measurement was removed and “electromagnetic”¹ was added. At the 2011 American Diabetes Association conference the poster showed that, within seven days of calibration of the unit, the average error in home-use situations was 25.5%, and that 42% of the points were in the “B” region of the Clarke Error Grid, with 4% in the “C” and “D” regions. These would generally not be considered clinically acceptable results, but in more recent studies with 2016 dates, the performance is reported to be much improved.

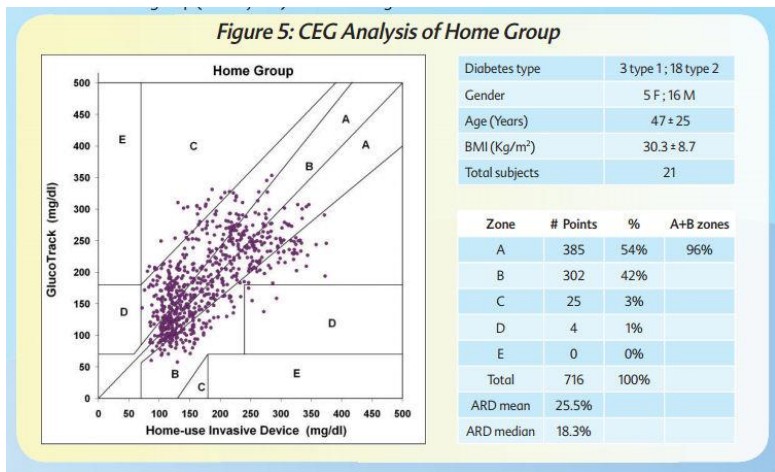

¹ The patent describes the change to impedance from conductance: “To reflect changes in the tissue electrical impedance caused by varying glucose, the electromagnetic channel (EMC) includes a special auto-oscillating circuit. [] Frequencies may range from 5 K Hertz (5 KHZ) up to 100 K Hertz (100 KHZ) and the amplitudes vary from about 0.1 volts to 1.5 volts.”

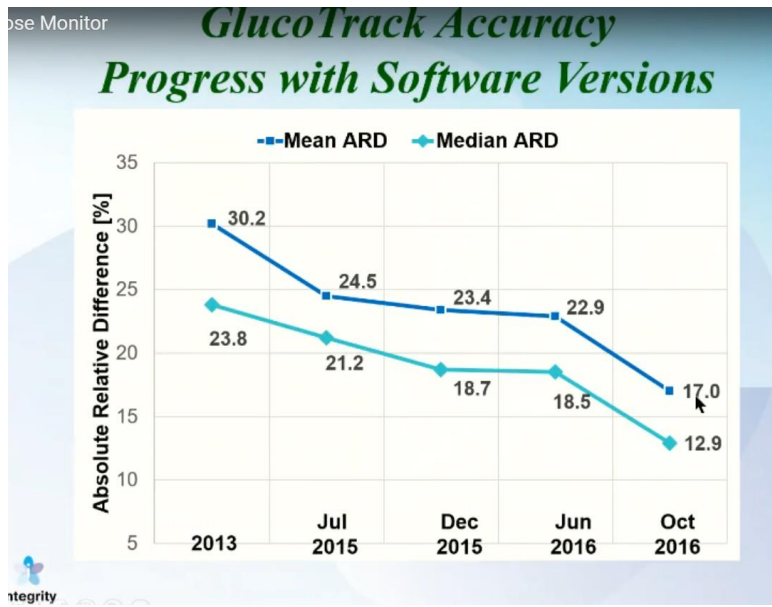

In June of 2013, Integrity received the CE Mark approval for its GlucoTrack® DF-F noninvasive blood glucose meter, which allows it to be sold in most of the European Union countries (this is one of just a few noninvasive meters to receive CE approval since the second version of the Glucowatch was approved in 2002¹). No submission has yet been made to the FDA to allow sale in the U.S. (they say they hope to have approval by 2019), and although there have been many reports of distributorships, it is not clear how many shipments of systems outside of Israel have been made. The company had two trials reported on clinicaltrials.gov, opened in 2007 and 2009, but in 2017, both were reported as “The recruitment status of this study is unknown. The completion date has passed and the status has not been verified in more than two years.”

A “hangout” interview with Medgadget is available [online](#), in which the founder, Avner Gal, explains and demonstrates the device. He demonstrates the use of the ear clip (attaching it to his ear backwards from the instructions on the screen), and that the measurement time is 60 seconds, but provides some highly suspect justification for the 6-month replacement interval for the clip, because “the spring might break.” The number of cycles before a compression spring breaks from fatigue is ordinarily measured in

¹ Pendra’s Pendragon received a CE Mark in 2003, Orsense in 2008, Cnoga, in 2011, and C8 Medisensors in late 2012. None of these other manufacturers had a system that was ready for the market, and that casts some doubt on the CE mark as a meaningful regulatory approval process.

millions, and any mechanical engineer worth his salt could design a spring for such a clip that would easily outlast the user. There is a constant conflict with a true noninvasive device—if it never wears out, the initial selling price is the only revenue source for the maker, and even with the recommended [selling price](#) of \$2,000, investors prefer a continuing revenue stream, which has now been established for this device at \$200 for two ear clips each year, but with some shaky justification. Gal spends time in the interview explaining that, because the name of their company includes “Integrity,” he won’t pretend that other analytes can be measured with their technology.¹ Apparently, that doesn’t extend to his justification of the need to replace the ear clip.

Yet another such combination has been patented by [Esenaliev](#) (US 8,135,450), who has performed research with and published investigations into optical coherence tomography (see that section) at the University of Texas Medical Branch in Galveston. It involves measuring changes in tissue dimensions (thickness, length, width, diameter, curvature, or roughness), as well as time of flight of ultrasound and optical pulses and “optical thickness.” It is reminiscent of the Integrity Applications approach above.

Another “combination” approach is BodyMedia, who had a patent application that published (US 2015-0282767 A1), and uses “machine learning techniques” to combine signals from body-worn sensors that include a “body motion sensor, a heat flux sensor, and a skin conductance sensor,” together with a “second set of signals comprising a heat flux high gain average variance [], a vector sum of transverse and longitudinal accelerometer [], and a galvanic skin response low gain [sensor].” BodyMedia was acquired by [Jawbone](#), and support for its devices was terminated in early 2016.

Another company, originally called “Drive Safe Glucose Monitoring Systems, Inc.” (now known as “DSGM Systems, ” and more recently relegated to just a [FaceBook page](#)), had a proposed product called Glusonic, which they say is “The first glucose monitor to combine invasive and non-invasive features. The GluSonic Alert™ glucose monitor will

¹ Because the measurement is heavily dependent on the metabolism of glucose for the thermal measurement, it’s unlikely that any other analyte outside of oxygen could be measured with the selected technologies, and that can be measured with a fingertip pulse oximeter that sells for less than \$15.

alert [the user] to dangerous lows or highs before they happen.” No technology is described, but the company’s website included the ubiquitous wristwatch picture (the picture file on their website was named “mock up”). They had extended the search for funding to a YouTube video named “Drive Safe Glucose Monitoring Systems, Inc. - Elevator Pitch” complete with “audience reaction” shots. As of 2017, the FaceBook page still says “DSGM Systems is commercializing a breakthrough technology to produce the first-of-its-kind, user-friendly, non-invasive glucose monitor that continuously tracks blood glucose levels and trends painlessly, in a wristwatch format.” William Cross, who is listed as President of DSGM on his LinkedIn page, has founded Vasocorp (a company with supplements for diabetes featured prominently on its [home page](#)), and has a U.S. Patent assigned to himself, rather than a company (U.S. 9,538,943), that issued in 2017 for a “combination invasive and noninvasive glucose monitor.” Both he and his venture strategy advisor have diabetes.



Evanescent Wave Spectroscopy-VivoMedical: A long-time darling of esoteric technology aficionados is a technique known as “evanescent wave” spectroscopy. When light is reflected from the interface between any two materials of different refractive indices, the light penetrates to a depth of approximately one-half wavelength of the light (for green light of 550 nm, the penetration is about 275 nm (0.275 microns)) into the second material. Although this approach has been attempted several times, in Japan and elsewhere, the thickness of dead skin everywhere on the outer surface of tissue (called the “stratum corneum”), is probably too great to allow light to interact with glucose using

this approach, and any glucose it holds is probably not closely related to current blood levels.

A Cupertino, California, startup called MedOptix (later renamed VivoMedical) sought to overcome this problem by measuring glucose in the extremely thin layer of sweat that forms on skin before it evaporates (after all, if a technique can only penetrate a very small distance into a material, an extremely thin film is no limitation). Unfortunately, as expressed in the Second Law, no reliable amount of glucose finds its way into sweat, whether the film is thick or thin, and this company has so far also failed to achieve success. After failing to obtain continuing funding for the evanescent wave approach, the company briefly moved to physical collection of sweat for glucose measurement, but investors were equally unenthusiastic about this principle that also violated the Second Law, and the company no longer exists.

Sweat – more than once a year, a means for measuring glucose in sweat is published. Here are the new ones for this edition.

Seoul National University: The [headline says](#), of a device developed jointly with Massachusetts flexible electronics company MC10 “This wearable patch uses sweat to monitor blood glucose levels and can automatically deliver medication with microneedles.” In work published in *Nature Nanotechnology*, it was reported “Researchers have created a patch that both monitors blood glucose and delivers medication when needed;” unfortunately, it does neither. While the technology uses graphene, the most current trending material, it can only measure glucose in sweat, which does not correlate well with blood glucose. They say “Once a high [glucose] level is detected, heaters in the patch start to dissolve a layer of coating, exposing microneedles that then release a drug called metformin that can regulate and reduce high blood sugar levels.” While metformin is the number one oral drug for people with type 2 diabetes, it is ineffective if injected. Another good-sounding, but totally impractical device.

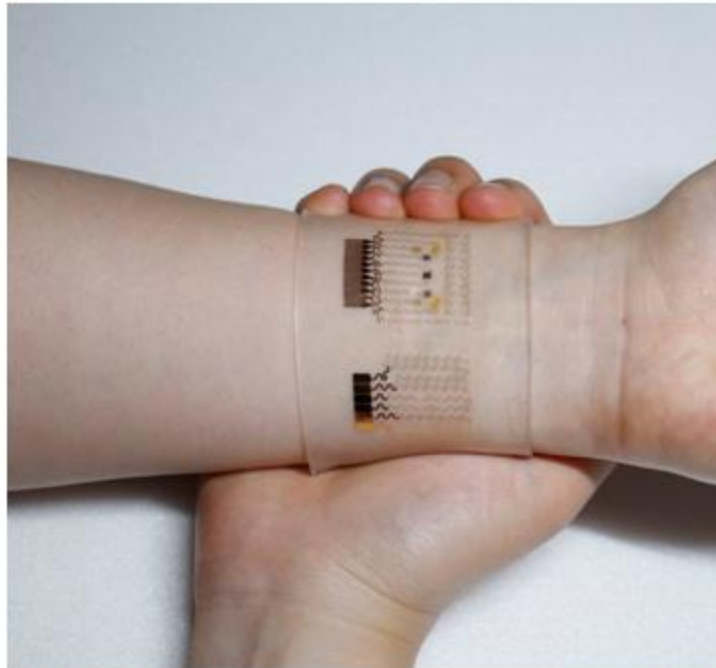

University of Texas, Dallas: In a study recently published online in the journal *Sensors and Actuators B: Chemical*, Dr. Shalini Prasad, professor of bioengineering in the [Erik Jonsson School of Engineering and Computer Science](#), and her coauthors demonstrated the capabilities of a biosensor they designed with the intent to reliably detect and quantify glucose in human sweat.

[Eccrine systems](#): This company, headquartered in Cincinnati, OH, has a PCT patent application (WO 2016/197116 A1) for detection of glucose (among other analytes) in sweat, with the intent of detection of “physiological states.” Acknowledging the variable glucose content of sweat over different rates of sweat production, they propose measuring electrolytes, sweat pH and rate, galvanic skin response, and others, to create a hypoglycemic profile for the user. They do not contend that they can monitor blood glucose using this fluid.

[Gentag](#): This company says it can provide “Pain-Free Diabetes Monitoring,” presumably from measurements of glucose in sweat, as described in U.S. patent US7969307B2, that issued in 2011. They stated in a September, 2015 article they shared with Eccrine in *The*

Economist that they had hoped to put such a product on the market in 2016, but had not by year-end.

To summarize, just like saliva and tears, sweat contains glucose, but not at levels that correlate well enough with blood glucose that it can be trusted for monitoring glucose for people with diabetes.

Retinal Pigment Regeneration

Fovioptics¹: This startup was founded in 1999 by Mark Rice, an anesthesiologist, and its glucose technology was based on measurement of the regeneration rate of visual pigment in the retina. The technology was encouraged by the observation that visual acuity (judged by color-matching studies following a bright light to bleach the pigments in the retina) for people with diabetes often returned much faster than for people without diabetes, and that the rate of recovery was variable from week to week. A paper published in 1995 by a researcher named Ostroy contended that the regeneration rate for visual pigment in excised mouse eyes depended strongly on the amount of glucose in the infusion solution.

Early results were equally promising and allowed obtaining of two rounds of venture capital financing, but continued investigation showed that the relationship was not robust enough to allow development of a product with the acute health impacts of a glucose monitor. To their credit, in 2006 when the principals made the decision to discontinue the effort, they returned a majority of the investors' unspent money.

Following its demise, one former employee of Fovioptics tried to build on the work done there by using a technique called a "electroretinogram:" an electrical signal detected from the conjunctiva of the eye that may have some dependence on glucose level (US 8,326,395, issued to Jack Gratteau in 2012). Another entrepreneur, Dan Burnett, briefly followed the technology by creating a company called Novoculi that looked into

¹ I served as a consultant, then as CEO and CTO for Fovioptics from 2003 to 2006. Because the proposed biochemical mechanism had a rate-determining step dependent on glucose concentration (and because the retina is so highly perfused by blood), it was one of the most promising approaches I had seen.

detecting the time at which visual sensitivity to movement returned after a bleaching episode. Neither approach has so far been shown to provide clinical accuracy. Yet another patent based on this technology appeared in 2014: US 8,812,097 B2, from inventors at Honeywell, where the detection of visual pigment regeneration is based on neurophysiological response sensed by EEG electrodes.

Fringe Players

This section has been reserved for investigators or technologies that exceed the norms of scientific techniques and behaviors.

Solid State Farms: Milton Fuller was an eccentric inventor who felt he would be able to measure glucose using “microwave spectroscopy,” basically by applying microwave energy at various frequencies to a fingertip, and measuring the amount of energy absorbed or reflected. Since little is known about the specifics of interaction between molecules in condensed media like tissue and microwaves, his conjectures were considered viable, if not persuasive. His research was rumored to have been sponsored at the level of a million dollars by Ames (Bayer) in 1986 or 1987, and he continued to insist for many years that his techniques would work. Unfortunately, he was also convinced that one of his researchers had been murdered by a “large corporation” just as they were closing in on the solution, and it continued to evade him.¹ Milton passed away between the first and second editions of this book.

The company, renamed Pindi Products, maintained a gossamer existence for a number of years after renaming the technology “radiomolecular magnetics.” The technology was at

¹ Milton was one of the first investigators I spent time with at LifeScan, and I found his personality and technical investigations so unusual that I made it a requirement that any employee who joined the noninvasive research group visit him during the first few weeks of employment. The experience helped to calibrate them with regard to the claims and procedures they would encounter for as long as they participated in the evaluation of noninvasive techniques. The Pindi website in 2006 gave this description of Milton: “As someone with long experience and wisdom in the ways of business and intellectual property, Milton can be thought of as the guardian or captain of the technology. He has prevented numerous attempts at theft and takeover, and he has successfully guided and grown the company towards its destiny as the premier non-invasive technology and products company in the world.”

one time licensed to a company called Diabetex International in Connecticut, but that company appeared to also pass from existence some years ago.

However, in 2012, the patents issued to Milton Fuller and Pindi Products were assigned to RF Science & Technology, which began raising funding. One report on the company at that time was titled “**RF Science and Technology**, a Stalled Device Startup With Bloodless Glucometer Tech Seeks Biz Partners. Any Takers?” In 2015, an even newer company named [Glucorecs](#), under the leadership of John Vigurie in Mountain View, CA, raised angel funding for the same technology and began trying to raise funds from venture capital sources. Since some of the patents still bear Milton Fuller’s name, this approach has been given honorary “30-Year Club Membership.”



Glucorecs Finger Sampling

Visionary Medical Products Corporation: This was an example of a company president’s worst technology nightmare. An entrepreneur, Thomas Castellano, had been seated next to a member of Johnson & Johnson’s executive committee on a commercial airline flight and convinced him that his company had truly achieved noninvasive glucose measurement. The executive called LifeScan’s president, insisted that a meeting be set up between the company and LifeScan’s senior management and that the results of the meeting be sent to him as soon as we had completed our discussion.

Unfortunately, the entrepreneur had neither a device nor a technology for noninvasive measurement, and was unable to articulate a plan for participating in the field. He brought along a “business advisor,” a man who touted connections to the Hollywood film industry but with no experience in diabetes. LifeScan’s management team listened politely to the presentation but informed them that there was no opportunity to fund or invest in a company with no visible technology. The result was that the “business advisor” wrote a diatribe to the J&J executive, describing that the company managers were ignorant about diabetes, that they were unable to comprehend the technology presented, and that the group was rude and insensitive to their visitors. Fortunately, his communication was so extreme that the J&J executive could see why the LifeScan group chose not to pursue the technology.

Some of Castellano’s patents for insulin “pens” with glucose meters attached were sold to Becton Dickinson and became the basis of a patent infringement suit filed against Insulet Corporation, a maker of “patch” insulin pumps.

Dr. Schmidt: Although this account attempts to be charitable, there are certain individuals whose motives or balance must be questioned. One such was an advertisement for a noninvasive device from a Dr. Schmidt in Ulm, Germany, that appeared in the early 1990’s. When a local LifeScan sales representative visited the listed address, he found only Dr. Schmidt’s Sex-shoppe, with many exotic devices, but no indication of anything intended for glucose measurements.

Hemadyne: Another was an individual named Al Snitkof, whose Hemadyne Company in White Plains, NY, announced through the unusual medium of Internet diabetes discussion groups that he had solved the problem of measuring glucose, had developed an instrument that used a single laser diode, and would be producing it and selling it at very low cost to people in need. Several attempts to meet with him to discuss his invention led to less-than-credible excuses after the arrival of industry representatives at the assigned meeting places. His device was never commercialized, and one suspects, never existed in workable form.

Summary

In laboratories around the world, the pursuit continues today and is likely to continue until techniques have been perfected.¹ The combination of economic and emotional factors creates a powerful driving force, and there is an inexhaustible supply of bright, determined researchers who will struggle against the historical odds until success is finally achieved.

As in the attempts detailed here, the horizon will continue to be clouded by spurious correlation, incomplete understanding of the sources of error, lack of rigorous evaluation of results and wishful interpretation of data. Unlike the cure for cancer, where partial success has been achieved in many areas, this one still seeks a breakthrough. It is hoped that the attempts detailed here will help to prevent others from repeating past mistakes and premature announcements, but a rational assessment would suggest that many more lie ahead.

A March 1998 edition of an IEEE (Institute of Electrical and Electronic Engineers) publication called the *Leos Newsletter* was devoted to techniques for noninvasive measurement of glucose. In an overview paper in that edition, R. W. Waynant and V. M. Chenault, of the Office of Science and Technology and Office of Device Evaluation, respectively, in the Food and Drug Administration's Center for Devices and Radiological Health had the following comments:

"With ever improving advances in diagnostic technology, the race for the next generation of bloodless, painless, accurate glucose instruments has begun.

However, many hurdles remain before these products reach the commercial marketplace.

Calibration of the instruments and validation of the results obtained by the optical methods under different environmental conditions and used by different patient populations (i.e., different ages, sizes and ethnic origins) must be performed. The devices may have to be calibrated to individual users.

¹ As in the blood glucose monitoring market today, the different forms of diabetes, the varying requirements of different regulatory agencies around the world, the range of individual preferences of consumers, and the intense competition among the participating companies would certainly allow for more than one successful product.

Current instrumentation lacks specificity due to substantial chemical and physical interferences. The devices use multivariate regression analyses that convert the optical signal to a glucose concentration. Large amounts of data are used to build the glucose model and must take into consideration the concentration range, sampling environment and other factors involved in the analysis. First an instrument must be designed that accurately detects glucose concentration. Correlation and clinical interpretation of this value, in respect to the patient's "true glucose" value, is imperative for optimum therapy and disease management.

Considerable progress has been made in the development of non-invasive glucose devices however, at this time, frequent testing using invasive blood glucose determination via fingerstick provides the best information for diabetes disease management."

(<http://www.ieee.org/organizations/pubs/newsletters/leos/apr98/contents.htm>)

As Jim Berg, a spokesperson for MiniMed, one of the long-term players in this field, was quoted in a March 1997 article in *Medical Device and Diagnostic Industry* magazine:

"People's lives are involved and we don't want to suggest that this technology is right around the corner. This is very tricky, difficult work."

These assessments remain essentially unchanged over a decade later. The complexity of the measurement process and the difficulty of keeping investigations funded and on the right track have so far conspired to prevent an effective solution from reaching the millions of patients whose need for it grows daily.

That corner, that horizon stretches out into the distance.

Afterword

After returning to “retirement” in 2006 following my work with Fovioptics, I am continuing (still in 2017) to assist companies who choose to pursue this Sisyphean task, if only to aid them in preventing the repeat of past mistakes. There are more companies and technologies than I have disclosed here, but I have exhausted those about which I can speak freely—a number are still governed by nondisclosure agreements.

I realize that this exhaustive discussion of all that has not succeeded can lead readers beyond healthy skepticism and toward unproductive cynicism, and cause some to wonder if that progression has already occurred for me. In spite of all the failures (and quite likely, because I have been close to so many of them), it is still my fond wish that someday, somewhere, someone will find the solution to this intensely recalcitrant problem and realize the benefits for all people with diabetes worldwide.

Appendix A

Hunting The Deceitful Turkey

Story by Mark Twain

When I was a boy my uncle and his big boys hunted with the rifle, the youngest boy Fred and I with a shotgun--a small single-barreled shotgun which was properly suited to our size and strength; it was not much heavier than a broom. We carried it turn about, half an hour at a time. I was not able to hit anything with it, but I liked to try. Fred and I hunted feathered small game, the others hunted deer, squirrels, wild turkeys, and such things. My uncle and the big boys were good shots. They killed hawks and wild geese and such like on the wing; and they didn't wound or kill squirrels, they stunned them. When the dogs treed a squirrel, the squirrel would scamper aloft and run out on a limb and flatten himself along it, hoping to make himself invisible in that way-- and not quite succeeding. You could see his wee little ears sticking up. You couldn't see his nose, but you knew where it was. Then the hunter, despising a "rest" for his rifle, stood up and took offhand aim at the limb and sent a bullet into it immediately under the squirrel's nose, and down tumbled the animal, unwounded, but unconscious; the dogs gave him a shake and he was dead. Sometimes when the distance was great and the wind not accurately allowed for, the bullet would hit the squirrel's head; the dogs could do as they pleased with that one--the hunter's pride was hurt, and he wouldn't allow it to go into the gamebag.

In the first faint gray of the dawn the stately wild turkeys would be stalking around in great flocks, and ready to be sociable and answer invitations to come and converse with other excursionists of their kind. The hunter concealed himself and imitated the turkey-call by sucking the air through the leg-bone of a turkey which had previously answered a call like that and lived only just long enough to regret it. There is nothing that furnishes a perfect turkey-call except that bone. Another of Nature's treacheries, you see. She is full of them; half the time she doesn't know which she likes best--to betray her child or protect it. In the case of the turkey she is badly mixed: she gives it a bone to be used in getting it into trouble, and she also furnishes it with a trick for getting itself out of the trouble again. When a mamma-turkey answers an invitation and finds she has made a mistake in accepting it, she does as the mamma-partridge does--remembers a previous engagement--and goes limping and scrambling away, pretending to be very lame; and at the same time she is saying to her not-visible children, "Lie low, keep still, don't expose yourselves; I shall be back as soon as I have beguiled this shabby swindler out of the country."

When a person is ignorant and confiding, this immoral device can have tiresome results. I followed an ostensibly lame turkey over a considerable part of the United States one morning, because I believed in her and could not think she would deceive a mere boy, and one who was trusting her and considering her honest. I had the single-barreled shotgun, but my idea was to catch her alive. I often got within rushing distance of her, and then made my rush; but always, just as I made my final plunge and put my hand down where her back had been, it wasn't there; it was only two or three inches from there and I brushed the tail- feathers as I landed on my stomach--a very close call, but still not quite close enough; that is, not close enough for success, but just close enough to convince me that I could do it next time. She always waited for me, a little piece away, and let on to be resting and greatly

fatigued; which was a lie, but I believed it, for I still thought her honest long after I ought to have begun to doubt her, suspecting that this was no way for a high-minded bird to be acting. I followed, and followed, and followed, making my periodical rushes, and getting up and brushing the dust off, and resuming the voyage with patient confidence; indeed, with a confidence which grew, for I could see by the change of climate and vegetation that we were getting up into the high latitudes, and as she always looked a little tired and a little more discouraged after each rush, I judged that I was safe to win, in the end, the competition being purely a matter of staying power and the advantage lying with me from the start because she was lame.

Along in the afternoon I began to feel fatigued myself. Neither of us had had any rest since we first started on the excursion, which was upwards of ten hours before, though latterly we had paused awhile after rushes, I letting on to be thinking about something else; but neither of us sincere, and both of us waiting for the other to call game but in no real hurry about it, for indeed those little evanescent snatches of rest were very grateful to the feelings of us both; it would naturally be so, skirmishing along like that ever since dawn and not a bite in the meantime; at least for me, though sometimes as she lay on her side fanning herself with a wing and praying for strength to get out of this difficulty a grasshopper happened along whose time had come, and that was well for her, and fortunate, but I had nothing--nothing the whole day.

More than once, after I was very tired, I gave up taking her alive, and was going to shoot her, but I never did it, although it was my right, for I did not believe I could hit her; and besides, she always stopped and posed, when I raised the gun, and this made me suspicious that she knew about me and my marksmanship, and so I did not care to expose myself to remarks.

I did not get her, at all. When she got tired of the game at last, she rose from almost under my hand and flew aloft with the rush and whir of a shell and lit on the highest limb of a great tree and sat down and crossed her legs and smiled down at me, and seemed gratified to see me so astonished.

I was ashamed, and also lost; and it was while wandering the woods hunting for myself that I found a deserted log cabin and had one of the best meals there that in my life-days I have eaten. The weed-grown garden was full of ripe tomatoes, and I ate them ravenously, though I had never liked them before. Not more than two or three times since have I tasted anything that was so delicious as those tomatoes. I surfeited myself with them, and did not taste another one until I was in middle life. I can eat them now, but I do not like the look of them. I suppose we have all experienced a surfeit at one time or another. Once, in stress of circumstances, I ate part of a barrel of sardines, there being nothing else at hand, but since then I have always been able to get along without sardines.

Index

- “bandage” glucose sensor, 16
- 3 Wave Optics, 158
- 510(k), 34
- 9 to 5 Mac*, 57
- A.R.M., 5
- A1c, 96
- Abbey Biosystems, 125
- Abbott, 12, 63, 70, 122, 171
- Abbott Bichromatic Analyzers, 124
- Abbott Diabetes Care, 89
- absorbance, 42
- Accu-chek, 8
- Accu-chek bG, 7
- acetoacetate, 83
- acetone, 83
- Advantest Corporation, 58
- AgaMatrix, 22, 90
- Agilent Technologies, 130
- Agrawal, 81
- Aidan Furlong, 127
- Aimedics, 88
- Al Snitkof, 186
- albumin, 112
- Albumin, 33
- Albuquerque, 133
- alcohol, 135
- Alcon, 76, 78
- Alethus, 54
- algorithm, 45
- alternate site, 51
- alternate site testing, 18
- Amay J. Bandodkar, 156
- American Association for Clinical Chemistry, 28
- American Diabetes Association, 28, 177
- Americare, 72
- Ames, 3
- Ames Reflectance Meter, 5
- Amylin Pharmaceuticals, 14
- Animas, 155
- Ansari, 64
- anterior chamber, 62
- Anthony Feola, 141
- Anton Clemens, 5
- Apple, iii, 57, 90
- Applied Nanodetectors, Ltd, 83
- aqueous humor, 39, 62, 74
- Aradigm, 131
- Argose, 122, 162
- Arizona State University, 79
- Ark-Ray, 7
- artificial pancreas, 22
- ASN Technologies, 163
- AstraZeneca Challenge, 95
- Avner Gal, 178
- Azurite, 166
- B.B. King, 21
- Babak Parviz, 78
- Baker Instruments, 21
- ballistic” photons, 67
- Band-aid, 13
- Battelle Insitute, 123
- Baxter, 11
- Bayer, 12, 21, 70, 120, 184
- Becton-Dickinson, 162
- benchtop, 38
- beta-hydroxybutyrate, 83
- Better Life Technologies, 173
- BICO, 142, 147
- bidet, 53
- big data, 15
- BiliChek, 170
- bilirubin, 170
- biocompatible, 23
- Biocontrol, 24, 141, 148
- Biocontrol Systems, 147
- BioDynamics, 7
- bio-electromagnetic resonance, 165
- Bio-Impedance General, 89
- Bio-Impedance General Ltd, 166
- Biolab Technologies, Ltd, 175
- Biolinq, 157

bionanotechnology, 77
 BioPeak, 162
 Biopie, 140
 BioSign, 158
 Biostators, 120
biothermophotonic, 175
 Biovotion, 164
 birefringent, 62
 blinded, 119
 blood alcohol, 83
 blood ketones, 83
 blotted, 9
 Bob Coleman, 121
 Bob Rosenthal, 12, 149
 body fat meters, 150
 BodyMedia, 179
 Boehringer Mannheim, 7, 12, 136, 170
 Brain Tunnelgenix Technologies, 54
 breadboard, 38
 Breath, 83
 Breath—Another Cautionary Tale, 86
 Brent Cameron, 63
 Brien Holden, 64
 buccal membrane, 69
 bulk properties, 106
 Buyers Strike!, 71
 Bydureon, 14
 Byetta, 14
 C8 Medisensors, 57, 178
 Cal Tech, 95
 calibration, 113
 Calibration, 115
 calibration interval, 118
 Calisto, 165
 carbon monoxide, 85
 cardboard box, 27
 causation, 113
 CE mark, 163
 CE Mark, 178
 Cell Robotics, 18
 Cercacor, 32, 41, 138, 148
 CGM, 15
 Chapter Seven bankruptcy, 130
 Charles (Chuck) Peterson, 130
 chemical structure, 33
 chemometric, 115, 132
 chemometrics, 45
 Chemstrip bG, 7
 chloride ion, 86
 cholesterol, 112
 Chowdhury, 155
 ciliary process, 63
 clamp studies, 121
 Clarke Error Grid, 101
 Clinical Studies, 119
 clinicaltrials.gov, 120
 Clinitest, 3, 4
 Clintech, 171
 closed-loop, 22
 CME Telemetry, 127
 Cnoga, 139
 colligative properties, 106
 collision computing, 139
 color-matching, 183
 Compact Imaging, 173
 company stores, 13
 confocal scanning laser Doppler
 microscopy, 67
 conjunctiva, 69, 80
 Consensus Error Grid, 101, 104
 consultant, 134
 consultants, 94
 contact lens, 80
 contamination, 73
 continuous measurements, 22
 copper sulfate, 17
 cornea, 62
 correlation, 113
 Correlation, 98
 correlation coefficient, 99
 Cost, Comfort and Convenience, 18
 Cross, 123
 CVS, 14
 Cybiocare, 89
 Cygnus, 69, 154
 cystic fibrosis, 72
 Dähne, 123
 Dan Burnett, 183
 David B. Sacks, 28
 David Cunningham, 28
 David Kessler, 142
 David Kliff, 27

David Mendosa, 27
 David Purdy, 141, 146
 Dawood Parker, 125
 Daylight Solutions, Inc, 60
de novo classification, 91
 Dean Kamen, 129, 134
 Debiotech, 22
 Deceitful Turkey, 190
 deep pockets, 41
 delay, 62
 Delphi Ventures, 163
 dental crown, 174
 deoxyhemoglobin, 31
 design controls, 38
 Device Master Record, 38
 Dexcom, 13, 15
 DexCom, 22, 54
 Dexcom Share, 91
 Dextrometer, 7
 Dextrostix, 4, 7, 12
 Diabetech, 9
 diabetes risk score, 96
 Diabetes Sentry, 88
Diabetex International, 185
 diabetologists, 120
 Diasense, 142
 Diasense, Inc., 148
 DiaSensor, 141
 differential scattering spectroscopy, 67
 diffuse reflectance, 43
 dipeptidylpeptidase inhibitors, 14
 dipsticks, 4
 Diramed, LLC, 57
 Direct 30-30, 12
 Directional Principle of the Second Law,
 70
 disinterested person, 114
 dispersive, 132
Dominion Assets, 148
 double barrel, 103
 Dow Chemical Company, 17
 DPP-4 drugs, 14
 Dr. Arnold, 151
 Dr. Randall Jean, 161
 Dr. Schmidt, 186
 Dream Beam, 12
**Drive Safe Glucose Monitoring
 Systems, Inc**, 179
DSGM, 179
 ear clip, 178
 Ear wax, 67
 earlobe, 65, 152
 Easy Check, 84
 Eccrine systems, 182
 Echo Therapeutics, 24, 70, 71
 Echo Therapeutics Inc, 71
 Ed Stark, 63, 126
 EEG electrodes, 184
 Efraim Landa, 56
 Eiken, 9
 Einstein, viii
 electrochemical, 11
 electrolyte balance, 98
 electrolytes, 68
Electronic Design News, 140
 Electro-optical Laboratories, 65
 electroporation, 171
 Electrozyme, 157
 Elevator Pitch, 180
 Eli Lilly, 12
 Ember, 32
 Emerging Technology Systems, 152
 emission, 42
 eMosquito, 22
 Emotional Considerations, 107
 eNano Health, 83
 endocrine system, 97
 endocrinologists, 120
 Enron, 109
 episodic, 22
 Ernest Adams, 4
 error band, 46
 Esenaliev, 179
 Eternity Healthcare, 82
 Ethanol, 50
 ethyl alcohol, 50
evanescent wave spectroscopy, 180
 Everett Dirksen, 111
 Exactech, 11
 experimenter expectation bias, 109
 Eyesense, 163
 Eytone, 7

false alarm, 23
 fasting plasma glucose, 96
 FDA, 34, 91, 102, 142, 151, 154
 femtosecond pulses, 55
 First Law, 98
 Fluent Biomedical, 60, 61
 fluorescence, 42
Fluorescence Spectroscopy, 28
 fluorescent tattoo, 157
 food challenge, 117
 forearm, 133
 foreign body response, 162
 fourier-transform, 132
 Fovioptics, 21, 183
 FP Technology, 173
 FPG, 96
 Fred Cooper, 141
 Free Patents Online, 38
 Freedom Meditech, 64
 FreeStyle “Tracker”, 89
 FreeStyle Flash, 15
 frequency of calibration, 118
 Frost & Sullivan, 29
 funnel-shaped, 46
 Futrex, 12, 149, 160
 Gartner’s Hype Cycle, vi
 Gary Small, 124
 gastric motility, 98
 GE Healthcare, 57
 Gen3 Partners, 166
 Gentag, 182
 George Wilson, 21
 Gerard Coté, 63, 157
 gingival crevicular fluid, 72
 Glenn Keeling, 141
 glowball, 43
 GLP-1 agonists, 14
 GLT Acquisition Corp, 138, 172
Glucall, 157
 Gluco Vista, 75
 Glucoband, 165
 Glucocheck, 9
 Glucolight, 172
 GlucoLight, 172
 Glucon, 24, 60
 GlucoNIR, 128
 GluControl, 30
 GlucoPad, 154
 Glucorecs, 122
 Glucosalarm, 53
 GlucoScan, 9, 10
 glucose found in saliva, 72
 glucose in water, 48
 glucose oxidase, 4, 77
Glucosense, 139
 GlucoSense, 165
 Glucoset, 175
 GlucoTrack, 178
 Glucoview, 77
 GlucoWatch, 70, 154
 Glucowise, 167
 Glumetrics, 24, 162
Glusonic, 179
 glycation, 67
 glycosylated, 33
 Glycosylated hemoglobin, 33, 96
 Gobe, 168
 gold standard, 98
 Google, iii, 76, 77
 Google contact lens, 77
 Google Patents, 38
 graphene, 81
Green-turquoise Light, 175
 Greg Herman, 78
 Greystone Associates, 29
 Grove Instruments, 122, 129
 Harry Potter, 167
 HAS-01, 88
 Healbe, 168
 Health Chem, 72
 Hemadyne, 186
 hematocrit, 118
 heme oxygenase, 85
 hemoglobin, 17, 73
 hemoglobin A1c, 67
 Herriot-Watt University, 60
 Hitachi, 95
 Holy Grail, 93
 Honeywell, 184
 Hong Kong Applied Science and
 Technology, 58
 Hugo R. Vogel, 30

humidity, 47, 113
 hydration, 47
 hydrogel, 175
 hydrogen peroxide, 4, 77
 hyperglycemia, ii
 hypoglycemia, ii
 hypoglycemic event, 89
 hypoglycemic events, 87
 Hypoglycemic Monitors, 87
 Hypomon, 88
 Hypo-Sense, 89
 iBGStar, 90
 iBot, 134
 IDE, 37
 IDM, 15
 iglucose, 84
 IIT, 24
 Imec VZW, 58
In Vivo Glucose Sensing, 27
 Indiana, Pennsylvania, 141
 Indiegogo, 65, 81, 168
 Individual Regression, 114
 Individual vs. Universal Calibration, 118
 informed consent, 37
 Infravitals Company, 160
 Ingo Flore, 95
 InLight Solutions, 57, 96, 122, 131
 Institut fur Biophysik, 60
 Institutional Review Board, 37
 Instrumentation Metrics, 136
 Insulet Corporation, 186
 insulin pump, 22
 Integrity Applications, 176
 Intel Corporation, 58
 intensive insulin therapy, 24
 interfaces, 73
 interferometer, 132
 interferometry, 132
 intermittent, 22
 interstitial fluid, 23
 Intralipid, 112
 intravascular fluid, 106
 Intuity Medical, 22
 Inverness Medical, 151
 Investigational Device, 36
in-vitro, 100
in-vivo, 100
 iontophoresis, 70
 iPhone, 90
 iPhone 5, 90
 IPO, 26
 iQuickIt Saliva Analyzer, 81
 iris, 62
 Irisense, 65
 i-SENS, 163
 iSense, 22, 163
ISO Standards, 104
 Israel, 75
 Israeli, 139
 I-SugarX, 64
 Jack Aronowitz, 72
 Jack Gratteau, 183
 Jack Nard, 145
 Jacob Wong, 56
 Jan Lipson, 57
 Janusz Buchert, 56
 Jean Cooper, 35
 Jeffrey La Belle, 79
 Jeremy Grata, 147
 Jet Propulsion Laboratory, 139
 Jin Gose, 139
 Joe Btfsplk, 149
 John Kaiser, 57, 136
 John L. Smith, 203
 John Smith, 131
 John Vigurie, 185
 John Whitehead, ii
 Johnson & Johnson, 10, 125, 155
 Johnson & Johnson Development Corporation, 129, 133
 Johnson & Johnson's Vision Care, 78
Joseph Frattarola, 176
 Joseph Wang, 80, 157
 Josh Hogan, 173
 Judah Gordon, 66
 Judge Sloviter, 146
 Julie Strenken, 28
 Jun Hu, 78
 Jupiter Devices, 167
 Kelly Close, 27
 KES, 126
 ketone bodies, 83

Khair, 160
 Krebs Cycle, 33
 Kromoscopy, 151
 Kumetrix, 22
 Kurabo Industries, 123
 Kyoto Dai-ichi, 7, 120
 Kyoto Dai-Ichi, 123
 lambertian, 43
 Lamda Guard, 167
 lancing devices, 17
Larry Ishler, 175
 Laser Atlanta, 64, 170
 Laura Andrews, 166
 Lee, 75
 Lein, 64
 Lein Applied Diagnostics, 64
 Leland Clark, 98
 Leman Micro Devices, 124
 lens, 73, 75, 170
 LifeScan, 9, 75, 126, 131, 136, 151, 152, 185
 LifeTrac Systems, Inc., 152
 Light Scattering, 66
 Lightning, 90
 LightTouch Medical, 130
 linear regression, 99
 low-carbohydrate diet, 83
 low-suspend, 22
 Ludwig Maximilian University, 55
 Lumidigm, 135
 Luminor Medical, 135
 Luminous Medical, 24, 131, 135
 LWI & Associates, 175
 LXN Corporation, 54
 M Pharmaceutical Inc, 22
Magnetics, 170
 Maillard" reaction, 33
 making the hammer heavier, 140, 176
 Manhattan Project, 133
 mannitol, 112
 Marc Abreu, 54
 March, 63
 Mark Arnold, 67, 124, 151
 Mark Rice, 183
 Mark Twain, x, 190
 market research, 29
 Martin Fox, 63
 Masimo, 138, 148, 158
 Masimo Laboratories, 158
 Matt Schurman, 172
 Max Liston, 124
 Max Planck Society, 55
 Mayo Clinic, 79
 MC10, 181
 meal challenge, 120
 Medella Health Inc., 79
 Medgadget, 178
 Medicare, 13, 18
 Medicare reimbursement, 14
 Medina ISF Equity LLC, 171
 MediSense, 11, 12, 122
 Medistron, 9
 Mediwise, 167
 MedOptix, 181
 Medpage, 88
 MedSci, 30
 Medtronic, 16, 22
 Mendosa on Meters, 27
 metabolism, 97
 methyl nitrate, 85
 mg/dl, 32
 Michael N Pitsakis, 148
 micro-droplets, 85
 MicroFluidic Systems, 84
 microliters, 12
 Micromem Applied Sensor Technologies, 170
 micrometer, 44
 microporation, 24
 Microporation, 170
 Microsoft, iii, 77
 MicroSoft, 78
 Microwave Spectroscopy, 161
 Midas touch, 26
 mid-infrared, 44, 54
 mid-infrared emission, 56
 Mid-Infrared Emission, 55
 Miles, 12
 Miles Laboratories, 3
 milligrams per deciliter, 32
Millimeter Wave, 59
 millimolar, 32

Milpitas, 133
Milton Fuller, 184
minimally invasive, 21
 MiniMed, 22, 162, 188
 Miraculins, Inc, 96
Misinformation, 53
 MIT, 58, 71
 MLR, 132
 model, 45
 mole, 137
 Molecular Devices, 22
 MolecuLight, 135
 mosquito, 22
 Motamedi, 172
 Motorola, 162
MRI, 161
 MRO, 173
 M-shaped, 120
 multiple linear regression, 132
 multivariate, 132
 multivariate techniques, 45
 museum, 30
 Myron Block, 151
 nail, 133
 nanomaterials, 81
 nanometer, 44
 NASA, 139
 near-infrared, 44, 123, 137, 141, 149,
 151, 152
 Near-infrared, 132
 Nemaura Pharma, 155
 Netherlands, 80
 NetScientific, 139
 neural network, 44
 New England Breath Technologies, 84
 Newton Photonics, 172
 Nexsense, 60
 NICE-SUGAR, 24
 Nightsense, 89
 NIMtek, 127
 Nippon Telegraph and Telephone, 60
 NIR, 123
 NIRDiagnosics, 122, 127
 Nobel laureate, 95
 noninvasive blood glucose monitoring,
 25
 nonpracticing entity, 148
 Northrup-Grumman, 60
 Noviosense, 80
 Novo Nordisk, 12, 14, 131
 Novoculi, 183
 Nuclear Magnetic Resonance, 161
 null hypothesis, 111
 Oak Ridge Clinical Chemistry
 Conference, 130, 132
 ocular ring, 76
 Oculir, 54
 offset, 116
 OGTT, 96
 Ok-Kyung Cho, 94
 Omnipod, 23
 one teaspoonful, 32
 One Touch, 10, 11, 13, 126
 One Touch Basic, 10
 One Touch meter, 10
 One Touch Ultra, 21
 Onsens, 89
 optical coherence tomography, 67
 Optical Coherence Tomography, 172
 Optical Rotation, 61
 Optical Rotation in Tissue, 65
 Optiscan, 122
 OptiScan, 24, 56, 122, 175
 oral glucose tolerance test, 96
 Orange Medical, 76
 Oregon State University, 78
 Or-Nim, 60
 Orsense, 66
 osmotic pressure, 106
 o-tolidine, 4
 Oulu University, 60
 outcomes, 15
 overfit, 127
 oxygen saturation, 31
 oxyhemoglobin, 31
 Panasonic, 12
 Pando, 168
 Parkes Error Grid, 105
 partial least squares, 132
 partitioning, 68
 patent holding company, 148
 patent infringement, 9

patent trolls, 41, 148
 patents, 38
 Patricia Sabatini, 145
 Patti LaBelle, 21
 Paul Carr, 168
 PCR, 132
 Pearson's Product Moment Correlation, 99
 Pendragon, 164
 Penlet, 17
 perfusion, 98
 peripheral circulation, 51
 permeability, 68
 permeation enhancers, 70
 Philippines, 145
 Philips, 78
 Philips Company, 85
 phonophoresis, 70
 phosphorescence, 42
Photoacoustic Spectroscopy, 59
 photometric, 11
 photonic glucose monitor, 89
 photoplethysmography, 158
 photothermal radiometric, 175
 Pietro Galassetti, 84
 pilocarpine nitrate, 72
Pindi Products, 184
 Pitman-Moore, 17
 plagiaristic, 29
 Platinum Partners, 71
 PLS, 132
 PMA, 35
 Pogo, 22
 Point of Care Urine Tester and Method, 53
 poke-around grant, 125, 127
polar, 70
 Politechnika Gdanska, 58
 polystyrene, 112
 Pop Test, 82
 Portland Protocol, 24
 PositiveID, 84
 Post Gazette, 145
 PPG, 158
 Precisense, 162
 predictive, 113, 115
 Prelude Skin-Prep, 71
 premarket approval, 35
 premarket notification, 34
 Princeton University, 55
 principal component regression, 132
 Principal Investigator, 37
 prism, 137
 Profil, 120
 propylene glycol, 72
 prototype, 38
 pseudoglucose, 127
 public domain, 41
 publish, 121
 pulsatile, 152
 Pulse Wave, 158
 Purdue University, 81
 Pyreos, 53
 Q-Step, 64
 Quandt, 63
 Quantum Catch, 64
 R, 99
 R², 99
 rabbits, 63
 Radio Frequency/Impedance, 164
radiomolecular magnetics, 184
 Raman spectroscopy, 57, 130
Raman Spectroscopy, 56, 57
 Rare Light., 55
 Ray Krauss, 172
 Ray Underwood, 9
 razor/razorblades, 13
 Recent advances, 29
 Red Cross, 17
 reference measurement, 98
 Reflolux, 8
 refractive index, 64, 66, 106
 regulations, 34
 reporter molecule, 162
 Research and Markets, 29
 Respirix, 84
 retina, 73
 Retinal Pigment Regeneration, 183
 retinal vessels, 74
 retinogram, 183
 RetiTech, 75
 retrospective correlation, 113, 127

reverse iontophoresis, 24, 154, 156
 RFID, 84
 RGMT, 131
 Richard Caro, 60
 Richard Feynman, 95
 Richard Peters, 152
 Rick Thompson, 131
 Ries Robinson, 130
 Rio Grande Medical Technologies, 130
 Robert Langer, 71
 Robert Rosenthal, 64, 160
 Robert S. Quandt, 39
 Robert Schlegel, 58
 Roche, 12
 Roche Diagnostics, 63
 Roger Phillips, 125
 room temperature, 47, 113
 root-mean-square, 52
 Rosedale, 22
 RSP Systems A/S, 58
 Sabbir Liakat, 55
 Sabirmedical, 160
 Sahara Energy, Inc, 22
 saliva, 67
 Saliva, 81
 Samsung, iii, 60, 124
 Samsung Fine Chemicals, 30
 Sandeep Gulati, 139
 Sandia National Laboratory, 130
 Sano Intelligence, 22
 Sanofi, 90
 Sansum Medical Research Institute, 130
 scatterplot, 99
 Scout, 96
 screening, 135
 Second Law, 68
 secrecy, 109
 Segway, 134
 Sen and Sarin, 79
 Senseonics, 57, 164
 Sensors for Medicine and Science, 162,
 163
 sensory nerves, 52
 Sensys, 57, 122, 132, 136, 137, 172
 Sentek, 77
 Seoul National University, 181
 SGLT2, 70
 Shalini Prasad, 182
 Sirraya, 60
 Siu, 81
 skin fluorescence, 122
 skin hydration, 98
 slope correction, 116
 Smart Glucose Meter Corp, 84
 smart phone, 163
 Smither Challenge, 133
 SMS Swiss Medical Sensor, 54
 Socrates Health Solutions, 65
 SoftTouch, 139
 Solianis, 164
Solid State Farms, 184
 Sontra, 24, 69, 70, 71
 sorbitol, 112
 specific rotation, 61
Specificity, 105
 Spectroscopic Techniques, 42
 spectrum, 42
 SpectRx, 24, 64, *See*
 specular reflectance, 43
 Spire Corporation, 58
 spurious\ correlations, 47
 squeeze techniques, 129
 StatTek, 7
 Steffes, 75
 Stephen Davies, vi
 Steve Gutman, 36
 Steve Malin, 136
 Stimulated emission, 56
 stratum corneum, 68
 Subdermal, 162
 subdermal reporter molecule, 122
 sudorific, 72
 sugar in a packet, 32
 SugarTrac, 152
 Sunshine Medical, 65
 sweat, 67, 72, 181
 sweat glands, 68
 sweat test, 72
 Symphony, 71
 T.G.M Technologies Ltd, 65
 tailoring, 133
 Taiwan Biophotonic Corporation, 58

tattoo, 162
Tattoos, 156
Tear Glucose Biosensor, 79
tears, 67, 76, 79
Tears, 76
Technical Chemicals & Products, Inc, 72
Technicon Instruments, ii, 21
Tecmed, 63
Ted Cadell, 127
teeth, 72
Teeth, 173
temperature, 51, 98
Temperature, 176
temperature of the fingertip, 175
Terahertz Spectroscopy, 58
Test 1, 112
Test 2, 112
Test 3, 113
Texas A&M University, 157
The Dream Beam, 149
The Elusive Goose, 29
The New Glucowatch, 155
TheraSense, 12
Thermal Techniques, 175
Third Law, 113
Thomas Castellano, 185
Thomas Cornsweet, 64
time of flight, 67
tissue dimension, 179
Toegepastnatuurwetenschappelijk
Onderzoek, 58
Toshiba Medical, 176
Touchtek Labs LLC, 171
TouchTrak Pro 2000, 30
transbuccal fluid, 81
Transdermal Measurements, 154
Transdermal Techniques, 67
transmittance, 42
Trebor, 64, 149
trendline, 99
Trendsmeter, 76
Trendstrip, 76
Tricorder, 20
triglycerides, 112
Trimark, 29
Truwest, 147
TRW, 60
turbid liquids, 112
two-point” re-calibration, 118
Tying Ideas to New Technologies, 89
tympanic membrane, 56
Type 1, ii
Type 2, ii
UFIT, 158
ultrasound, 70, 176
ultraviolet, 45
Uncertainty Principle Subsection of the
Second Law, 69
Univ. of Toledo, 65
universal calibration, 118, 133
University of California, San Diego, 80
University of California–Irvin, 84
University of Houston, 78
University of Iowa, 67
University of Leeds, 139
University of New Mexico, 131
University of Texas, 172
University of Texas Medical Branch,
172
University of Texas, Dallas, 182
University of Washington, 77, 78
urea, 112
urine, 3
Venture capitalists, 26, 94
Veralight, 96, 135
Verifica, 67
Verily, 16
vibronic coupling, 59
Victoza, 14
vision changes, 75
**Visionary Medical Products
Corporation**, 185
Visual Pathways, 64
vitreous humor, 74
Vitrophage, 63
VivaScan, 122, 129, 158
VivoMedical, 180, 181
Voice, 87
Volume Detection, 175
Wal-Mart, 14
Walter Ames Compton, 3
wash off blood, 4

wavenumber, 54
Wayne Front March, 39
Wayne March, 122
wearable, 16, 158
Wei-Chuan Shih, 78
white-out, 145
wine, 3, 100
Winnipeg, Manitoba, 96
wiped, 8
WorldCom, 109
wristwatch, ii, 22, 61, 165

Xhale, 85
Yale University, 54
Yan Feng, 82
Yellow Springs Instruments, 98
Yitzhsak Mendelson, 157
Yoon Ok Kim, 94
YouTube, 27
YSI, 98, 100
Zhi Xu, 160
Zurich Institute, 60
Zyomed, 139

About the Author

John L. Smith earned a Ph.D. in analytical chemistry from the University of Illinois, and has been involved in the design and development of instrumentation for making chemical measurements since the 1960s. Prior to becoming involved with clinical chemistry instrumentation in 1978, he spent four years as an analytical chemist with Union Carbide and five years as manager of product development with Princeton Applied Research Corporation (later part of EG&G) developing electrochemical instruments. He also taught chemistry at San Jose State University from 1991 to 1997 as an adjunct professor. He retired as the Chief Scientific Officer and Vice President of the LifeScan division of Johnson & Johnson in 1998. He now lives in the Pacific Northwest where he has once again attempted retirement.

He has participated in the evaluation of more than two hundred investigations into noninvasive glucose measurements and continues to consult for investors and for companies in that field.