



LG

REFRIGERATOR

SERVICE MANUAL

CAUTION
BEFORE SERVICING THE UNIT,
READ THE SAFETY PRECAUTIONS IN THIS MANUAL.

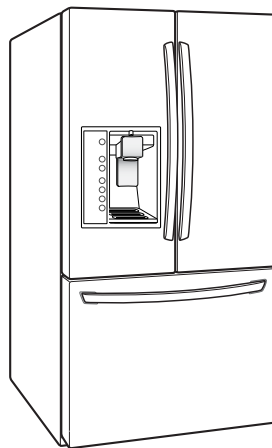

MODEL : LFXS29626*

COLOR : STAINLESS(ST)
SMOOTH BLACK(SB)
SUPER WHITE(SW)

CONTENTS

SAFETY PRECAUTIONS	2
1. SPECIFICATIONS	3
2. PARTS IDENTIFICATION	4
3. DISASSEMBLY	5
REMOVING AND REPLACING REFRIGERATOR DOORS	5
DOOR	6
SUB PCB	7
DOOR ALIGNMENT	7
FAN AND FAN MOTOR.....	7
DEFROST CONTROL ASSEMBLY	7
REFRIGERATOR LIGHT (TOP)	8-9
MULTI DUCT	9
DISPENSER	10
DISPLAY PCB	10
ICE BUTTON ASSEMBLY	10
WATER BUTTON ASSMEBLY	10
ICE CORNER DOOR REPLACEMENT	10
ICEMAKER REPLACEMENT	11
SUB PCB FOR WORKING DISPENSER	11
CAP DUCT MOTOR REPLACEMENT	12
HOW TO REMOVE A ICE BIN	13
HOW TO INSERT A ICE BIN	13
HOW TO REMOVE AND REINSTALL THE PULLOUT DRAWER	14-15
WATER VALVE DISASSEMBLY METHOD	16
FAN AND FAN MOTOR DISASSEMBLY METHOD.....	16
PULL OUT DRAWER	17
4. ADJUSTMENT	18
COMPRESSOR.....	18
5. CIRCUIT DIAGRAM	19
6. TROUBLESHOOTING	20
7. PCB PICTURE	21-22
8. Troubleshooting With Error Display	23-31
9. Troubleshooting Without Error Display	32-40
10. Reference	41-44
11. COMPONENT TESTING INFORMATION	45-52
12. COMPRESSOR TROUBLESHOOTING	53-65
13. ICEMAKER OPEARTING AND TROUBLE SHOOTING	66-68
14. ICEMAKER (Freezer Room) OPERATING METHOD AND TROUBLE SHOOTING	70-73
15. DESCRIPTION OF FUNCTION & CIRCUIT OF MICOM	74-77

SAFETY PRECAUTIONS

Please read the following instructions before servicing your refrigerator.

1. Unplug the power before handling any elctrical componets.
2. Check the rated current, voltage, and capacity.
3. Take caution not to get water near any electrical components.
4. Use exact replacement parts.
5. Remove any objects from the top prior to tilting the product.

1. SPECIFICATIONS

1-1 LFXS29626*

● 28.7cu.ft.

ITEMS	SPECIFICATIONS
DOOR DESIGN	Side Rounded
DIMENSIONS (inches)	35 3/4 X 36 1/4 X 70 1/4 (WXDXH) 28.7cu.ft
NET WEIGHT (pounds)	145kg (320lb)
COOLING SYSTEM	Fan Cooling
TEMPERATURE CONTROL	Micom Control
DEFROSTING SYSTEM	Full Automatic Heater Defrost
DOOR FINISH	PCM, VCM, Stainless
HANDLE TYPE	Bar
INNER CASE	ABS Resin
INSULATION	Polyurethane Foam

ITEMS	SPECIFICATIONS	
VEGETABLE TRAY	Clear Drawer Type	
COMPRESSOR	Linear	
EVAPORATOR	Fin Tube Type	
CONDENSER	Spiral Condenser	
REFRIGERANT	R-134a (145 g)	
LUBRICATING OIL	ISO10 (280 ml)	
DEFROSTING DEVICE	SHEATH HEATER	
LAMP	REFRIGERATOR	LED Module
	FREEZER	LED Module

● DIMENSIONS

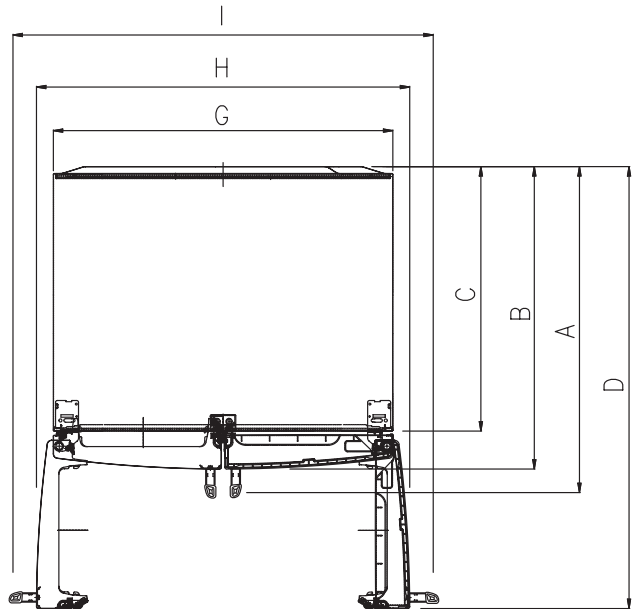
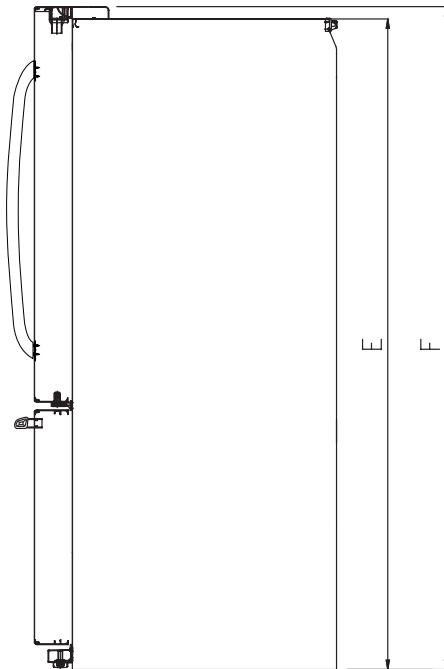

Description		LFXS29626*
Depth w/ Handles	A	36 1/4 in
Depth w/o Handles	B	33 3/4 in
Depth w/o Door	C	29 1/2 in
Depth (Total with Door Open)	D	48 1/8 in
Height to Top of Case	E	68 3/4 in
Height to Top of Door Hinge	F	70 1/4 in
Width	G	35 3/4 in
Width (door open 90 deg. w/o handle)	H	40 in
Width (door open 90 deg. w/ handle)	I	45 in

2. PARTS IDENTIFICATION

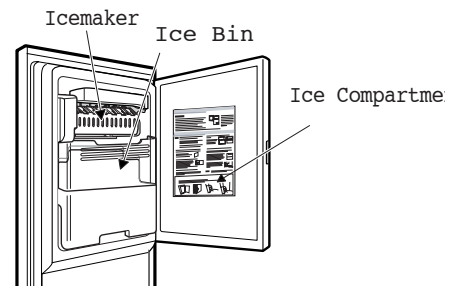
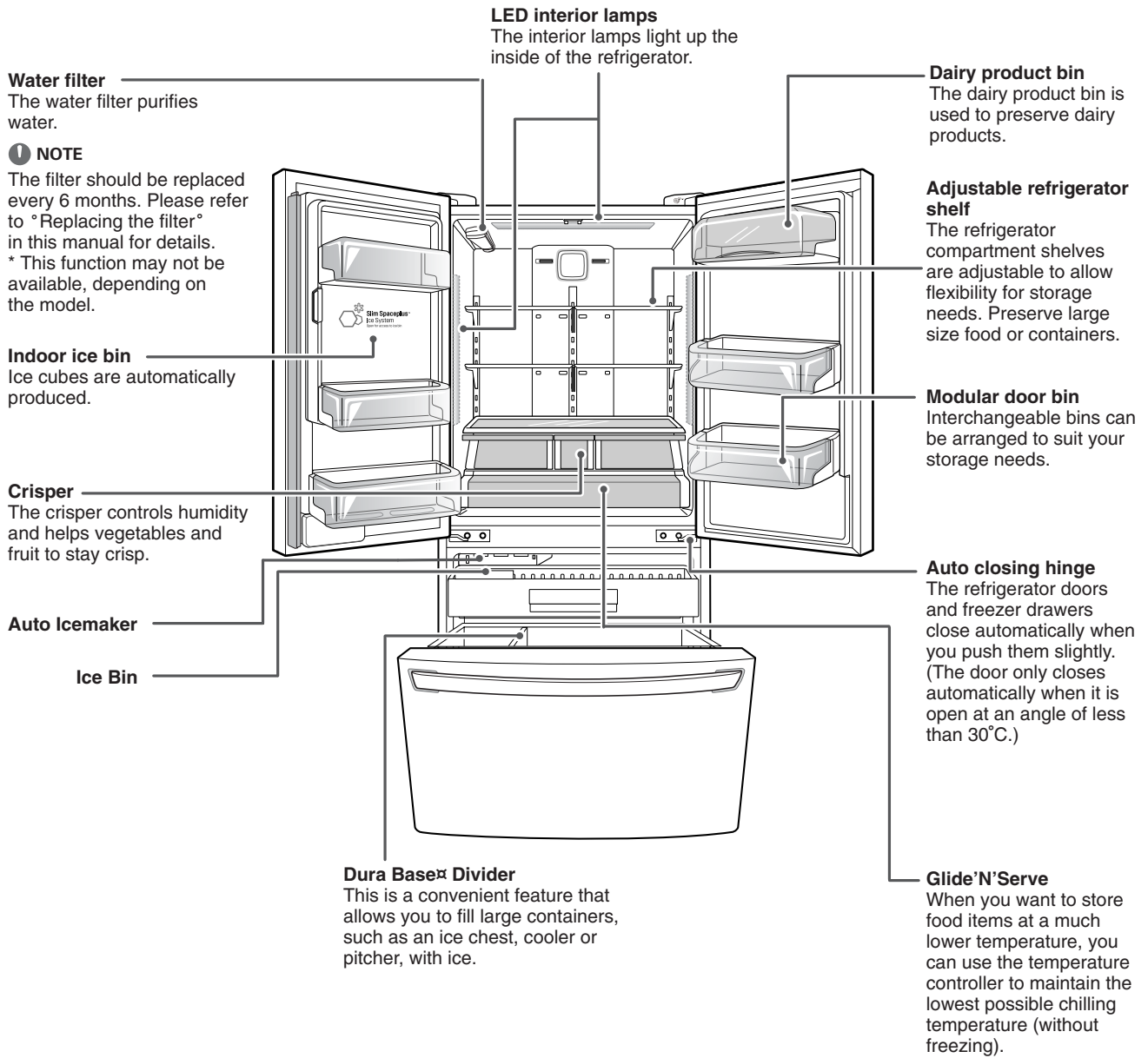

3. DISASSEMBLY

3-1 REMOVING AND REPLACING REFRIGERATOR DOORS

● Removing Refrigerator Door

▲ **CAUTION:** Before you begin, unplug the refrigerator. Remove food and bins from doors.

▶ Left Door -FIG. 2

1. Disconnect water supply tube by pushing back on the disconnect ring (3).-FIG. 1
2. Open door. Loosen top hinge cover screw (1).
- Use flat tip screwdriver to pry back hooks on front underside of cover (2). Lift up cover.
3. Disconnect door switch wire harness and remove the cover.
4. Pull out the tube.
5. Disconnect all 3 wiring harnesses (4). Remove the grounding screw (5).
6. Rotate hinge lever (6) counterclockwise. Lift top hinge (7) free of hinge lever latch (8).

▲ **CAUTION:** When lifting hinge free from the latch, be careful that door does not fall forward.

7. Lift door from middle hinge pin and remove door.
8. Place the door with the insides facing up, on a not scratch surface.

▶ Right Door -FIG. 3

1. Open the door, remove 1 screw on the top of the hinge cover. Loosen top hinge cover screw (1). Lift up cover (2).
2. Disconnect door switch wire harness and remove the cover.
3. Rotate hinge lever (3) clockwise. Lift top hinge (4) free of hinge lever latch (5).
4. Lift door from middle hinge pin and remove door.

▲ **CAUTION:** When lifting hinge free from the latch, be careful that the door does not fall forward.

5. Place the door with the insides facing up, on a not scratch surface.

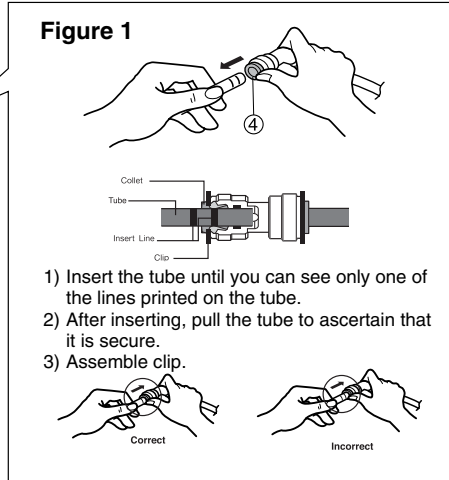
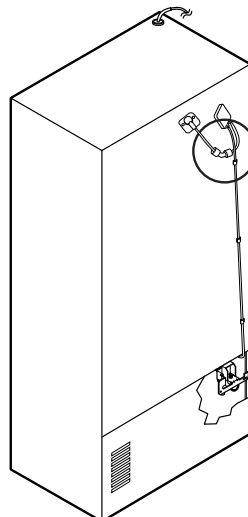
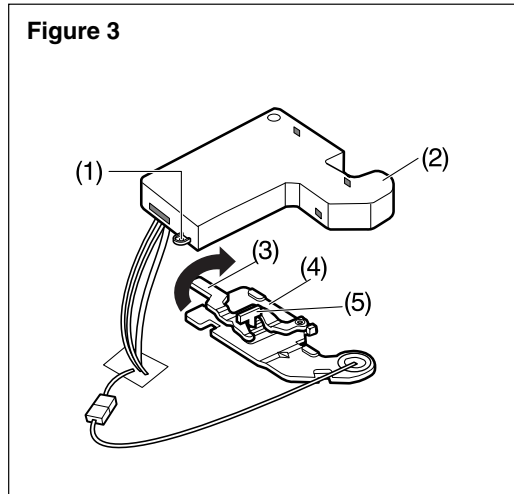
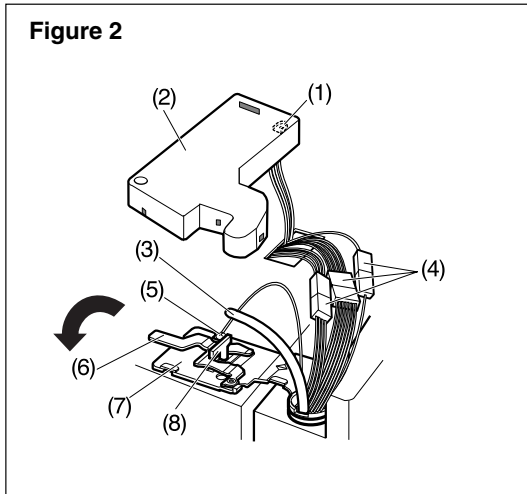

3-2 DOOR

● Mullion Removal

1. Remove 2 screws.

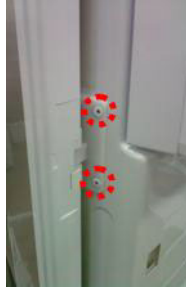

2. Lift mullion up carefully.



3. Disconnect wire harness.



● Door Gasket Removal

1. Remove gasket

Remove the gasket from gasket channel at doorliner as shown in the illustration below.

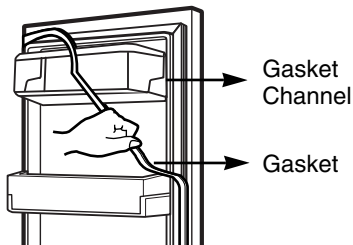

● Door Gasket Replacement

1. Insert gasket into channel

Insert and press gasket into channels at doorliner.

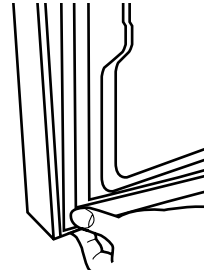

● Mullion Replacement

1. Connect wire harness.



2. Insert mullion into channel.

Insert the mullion into channel at door as shown below.



3. Assemble 2 screws.

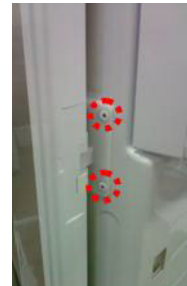

3-3 Sub,PCB

● Sub,PCB Removal

1. Remove 1 Screw.



2. Lift Sub PCB up carefully.



3. Reverse the Suc PCB cover.

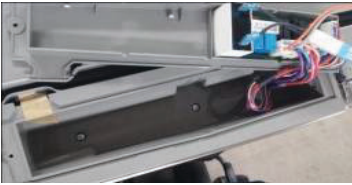

4. Disconnect capacitor housing.



5. Disconnect wire harness.



● Sub,PCB Replacement

1. Reverse the Suc PCB cover.



2. Connect wire harness.



3. Connect the capacitor housing.



4. Insert the Sub PCB sliding.



5. Assemble 1 screw.



3-4 Door Alignment

If the level of refrigerator doors is uneven, follow the instructions below to align the doors:
Turn the leveling legs (CCW) to raise or (CW) to lower the height of the front of the refrigerator by using flat blade screw driver or 11/32" wrench. Use the wrench (Included with the User Manual) to adjust the bolt in the door hinge to adjust the height. (CW to raise or CCW to lower the height.)

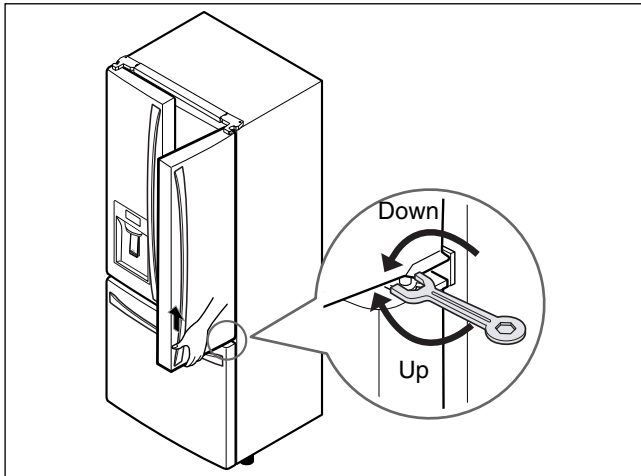

3-5 FAN AND FAN MOTOR

1. Remove the freezer drawer.
2. Remove the plastic guide for slides on left side by unscrewing phillips head screws.
3. Remove the grille assembly by removing four screws and pulling the grille assembly forward.
4. Remove the Fan Motor assembly by loosening 3 screws and disassembling the shroud.
5. Pull out the fan and separate the Fan Motor and Bracket Motor.

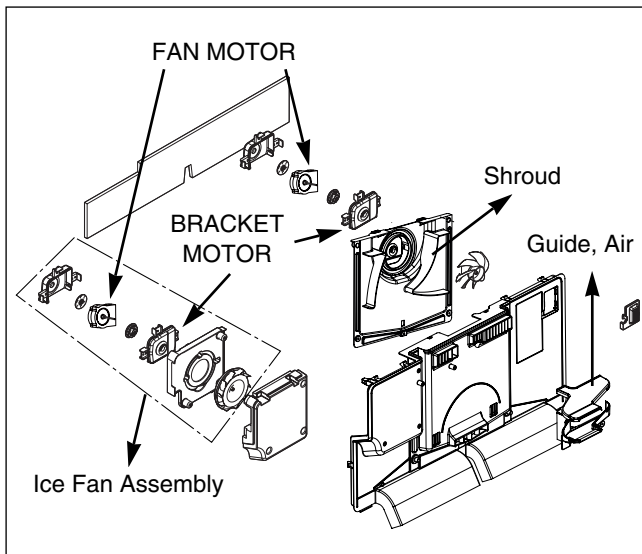

* Ice Fan Assembly Replacement

- 1) Remove the plastic guide for slides on left side by unscrewing phillips head screws.
- 2) Pull out the cover sensor to disassemble by using tools shown in the figure.
- 3) Pull out the cover grille to disassemble by using tools shown in the figure.
- 4) Put your hand into the inside of grille to disassemble shown in the figure.
- 5) Disconnect wire harness of the grille assembly.
- 6) Remove the Ice fan assembly by loosening all screws.



(1)



(2)



(3)



(4)

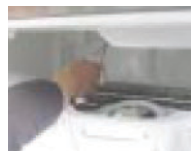

(5)



(6)

3-6 DEFROST CONTROL ASSEMBLY

Defrost Control assembly consists of Defrost Sensor and FUSE-M.

The Defrost Sensor works to defrost automatically. It is attached to the metal side of the Evaporator and senses its temperature. At 46F(8°C), it turns the Defrost Heater off. Fuse-M is a safety device for preventing over-heating of the Heater when defrosting.

1. Pull out the grille assembly. (Figure 1)
2. Separate the connector with the Defrost Control assembly and replace the Defrost Control assembly after cutting the Tie Wrap. (Figure 2)

GRILLE ASSEMBLY

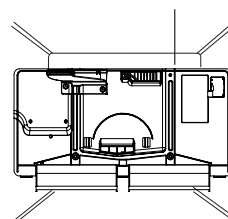

DEFROST-CONTROL ASSEMBLY

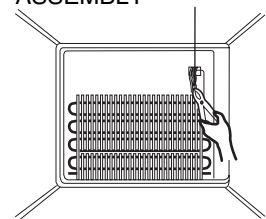

3-7 Refrigerator Light (Top)

Unplug Refrigerator, or disconnect power at the circuit breaker.

If necessary, remove top shelf or shelves.

3-7-1 Refrigerator Compartment Lamp

- 1) Unplug refrigerator power cord from electric outlet.
- 2) Put flat screwdriver into service hole and remove cover of refrigerator light.



- 3) Remove the LED assembly from connector.



- 4) Replace the LED assembly.

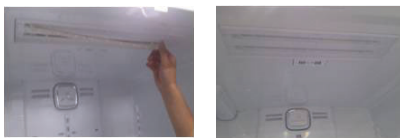

3-7-2 Refrigerator Light (Side)

1. Unplug refrigerator power cord from electric outlet.
2. Put flat screwdriver into service hole and remove cover of refrigerator light.



3. Remove the LED assembly from connector.



4. Replace LED assembly.



5. Assemble the cover in reverse order.

3-7-3 Cap Duct LED LAMP(Bottom)

1. Unplug refrigerator power cord from electric outlet.
2. Open the refrigerator door to need diassembly.
3. Put flat screwdriver into service hole, remove the cover of cap duct LED LAMP.



4. Remove the LED assembly from connector.



5. Replace LED assembly.



6. Assembly the cover in reverse order.

3-8 MULTI DUCT

1. Remove 2 screws and guide rail.

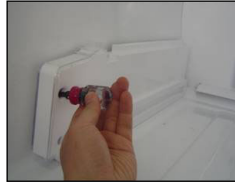

2. Remove the upper and lower Caps by using a flat screwdriver and remove 2 screws as shown figure.



3. Grip both side of multi duct, pull it out.



3-9 DISPENSER



1) Pull out the drain



2) Holding the inner side of the dispenser pull forward to remove.



3) If nozzle is interfered with button, push and pull out the bottom of button.



4) Remove the lead wire.

▲ CAUTION: When replacing the dispenser cover make sure the lead wire does NOT come off and the water line is not pinched by the dispenser.



3-10 DISPLAY PCB

As shown below, remove 1 screw on the PCB fixing screw. Remove the display PCB fixing screw.



Case, PCB



Display PCB

3-11 ICE BUTTON ASSEMBLY

- 1) Remove the 1 screw holding the lever.
- 2) Remove the spring from the hook.
- 3) Push and pull on the tab to remove.

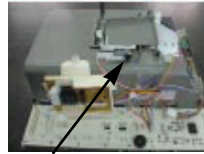

Button Lever



3-12 WATER BUTTON ASSMEBLY

- 1) Remove screws.
- 2) Grasp the Button assembly and lift.

Button Lever



3-13 ICE CORNER DOOR REPLACEMENT

- 1) Loosen the front screw as shown in the picture.
- 2) Lift up the hinge with one hand.
- 3) Pull out the Ice Corner Door with the other hand.



hinge

3-14 Icemaker replacement

1) Remove 3 screws marked in the picture below.



2) Grasp the bottom of motor cover assembly and pull it out slowly to remove.



3) Disconnect wire harness from wall of compartment.

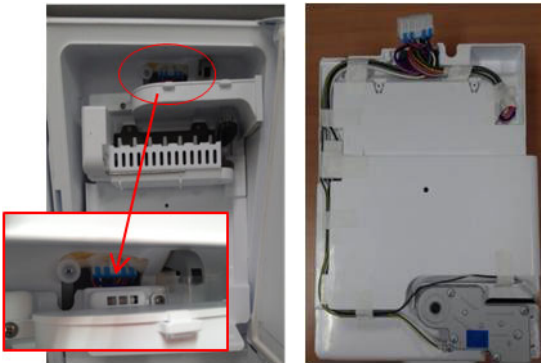

3-15 SUB PCB FOR WORKING DISPENSER

1) Disconnect the wire harness.



2) Remove 1 screw from PCB and replace with new PCB.



3-16 CAP DUCT MOTOR REPLACEMENT

1) Separate the Housing of the Cap Duct Motor.



2) Unscrew 3 screws to disassemble the motor.



3) When replacing the motor, check the position of the door duct and the link for proper fit.

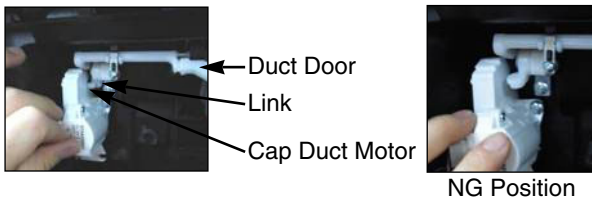

4) Insert 2 screws.



5) Push housing aside.



3-17 HOW TO REMOVE ICE BIN

1) Grip the handles, as shown in the picture.

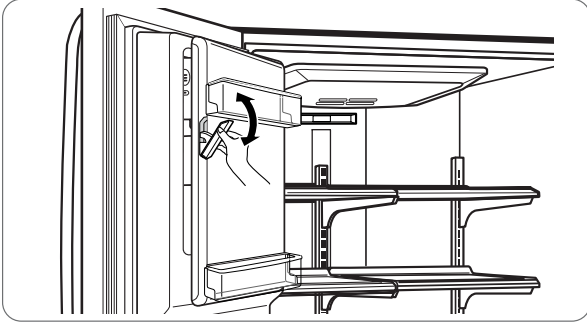

2) Lift the lower part slightly.

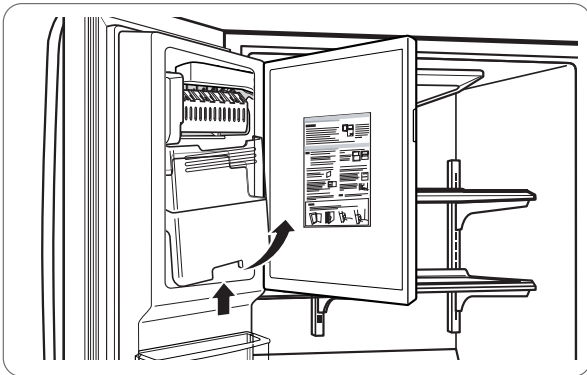

3) Take the Ice Bin out slowly.

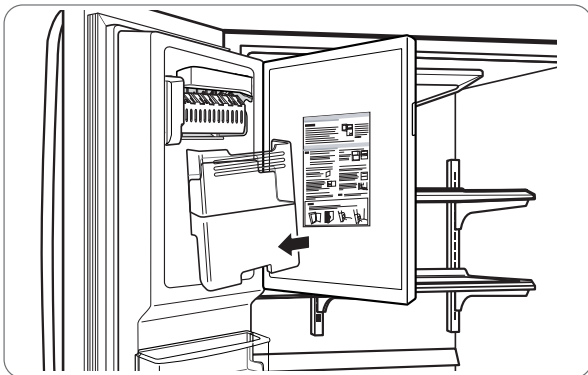

3-18 HOW TO PLACE ICE BIN IN POSITION

1) Insert the Ice Bin, slightly tilting it to avoid touching the Icemaker. (Especially, Ice-Detecting Sensor)

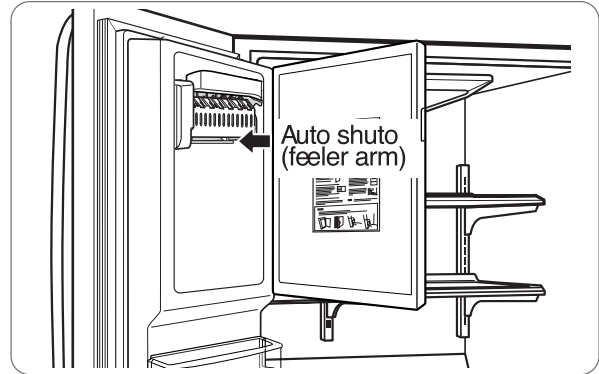

Note) Before remove ice bin, put on clean gloves for keeping clean ice bin.

3-19 HOW TO REMOVE AND REINSTALL THE PULLOUT DRAWER

3-19-1 Follow Steps to Remove

Step 1) Open the freezer door.



Step 2) Remove the lower basket.



Step 3) Remove the two screws from the guide rails (one from each side).

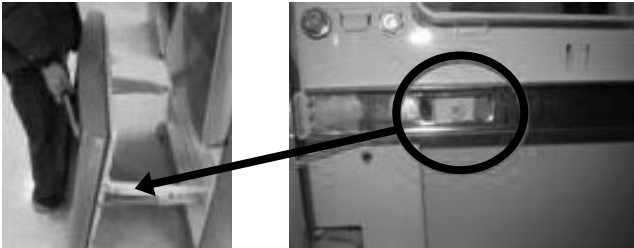

Step 4) Removal of the freezer door is done by lifting clear of the rail support. Fully extend both rails.



Step 5) Remove only 1 screw of gearice, and disassemble the bar and gearice

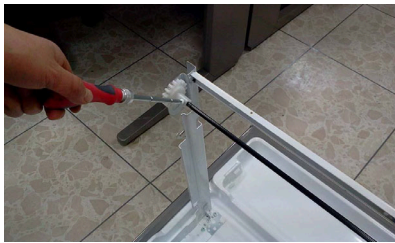

Step 6) Remove 2 screws of both side of supporter covers tv and disassemble the supporter cover tv.



3-19-2 Follow Steps to Reinstall

Step 1) Insert both side of supporter cover tv into connector rails, and then screw them.



Step 2) ① Assemble a bar and gear ice with screw.
② Push the otherside of the gear to inside of the bar.



Step 3) Put gear ice assembled with the bar by screw into connector rail's hole.

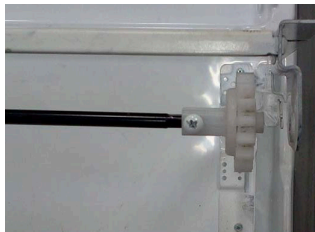

Step 4) Insert opposite gear ice into connector rail and screw them



Step 5) The rail system will align itself by pushing the rails all the way into the freezer section. Pull the rails back out to full extension.

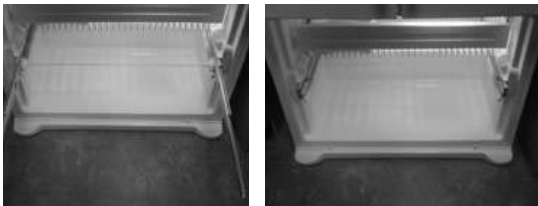

Step 6) Reinstall the freezer door by inserting the rail tabs into the guide rail.



* Assemble them like as pictures

Step 7) Reinstall the two screws into the guide rails (one from each side).

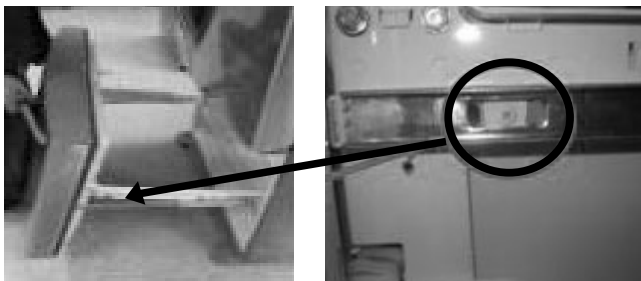

Step 8) Reinstall the lower basket, and close the freezer door.



3-20 WATER VALVE DISASSEMBLY METHOD

- 1) Turn off the water to unit. Remove the waterline from the valve.

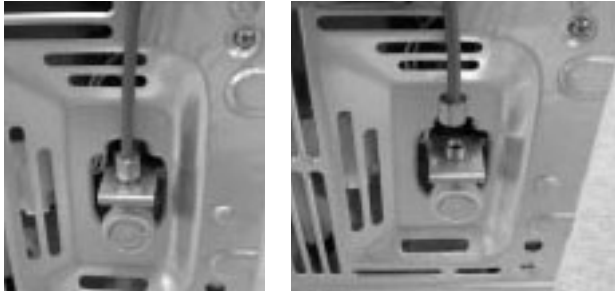

- 2) Remove cover and 1 screw from the valve.

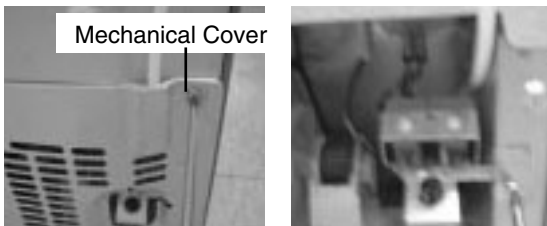

- 3) Separate the housing and remove the valve.



- 4) Remove the clip, and press the collet to separate the tube from the connector. Note: there maybe some water in the line.

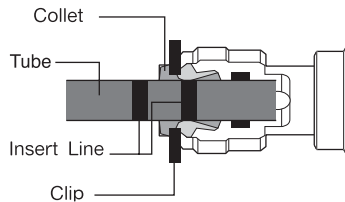

3-21 FAN MOTOR ASSEMBLY AND DISASSEMBLY METHOD

- 1) Remove screws for the Drain Pipe Assembly and the 1 connected to the Motor Cover.



- 2) Remove the screw from shroud and Separate the Fan motor assembly and Shroud.



Assemble in reverse order. Taking care to avoid.

1. Do not to bend the tube during assembly.
2. Press the Water Dispenser button letting water pour out, this checks for any leaks in the tube connection, this may vary depending on the water pressure (about 2 minutes.).

3-22 PULL OUT DRAWER

Top Drawer

1. To remove the Top drawer.

Pull the drawer out to full extension. Lift the front of the drawer up, then pull it straight out.

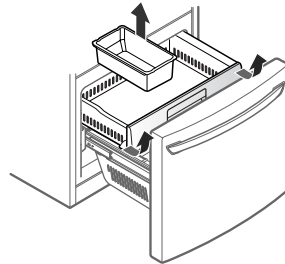

2. To install, slightly tilt up the front and insert the drawer into the frame and push it back into place.

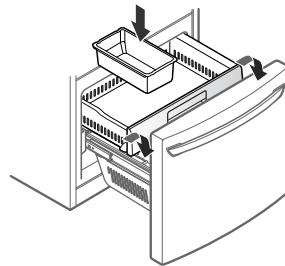

3-23 CAUTION : Sealed System Repair

Before making a sealed system repair : Start with the power cord unplugged from the outlet. Plug in the power cord and between 6 and 12 seconds after it has been plugged in, unplug it from the power source. this will allow both sides of the 3 way valve to be opened to allow for proper evacuation.

4. ADJUSTMENT

4-1 COMPRESSOR

4-1-1 Role

The compressor intakes low temperature and low pressure gas from the evaporator of the refrigerator and compresses this gas to high-temperature and high-pressure gas. It then delivers the gas to the condenser.

4-1-2 Note for Usage

- (1) Be careful not to allow over-voltage and over-current.
- (2) Do not drop or handle carelessly.
- (3) Keep away from any liquid.
If liquid such as oil or water enters the Cover PTC Compressor may fail due to breakdown of their insulating capabilities.
- (4) Always use the Parts designed for the compressor and make sure it is properly attached to the compressor. Parts may appear physically identical but could have different electrical ratings. Replace parts by part number and model number. Use only approved substitute parts.

4-1-3 Remove the cover PTC



(1) Remove the Cover Back M/C



(2) Remove two screws on comp base



- (3) Use a L-shaped flap tool to pry off the cover
- (4) Assembly in reverse order of disassembly

4-2-3 Compressor protection logic

- Since linear Comp conducts linear reciprocating motion, we have protection logic for compressor, motor and PCB as the below.

- Stroke Trip
During the operation, if stroke is above the target value, decrease the target volt by 3V.
- Current Trip
Current trip is set in order to protect compressor mechanical part and drive from the overcurrent that might arise during the operation.
Check the current for every 416.7us and if the Trip exceeds 1.86Arms more than three times at Comp ON, forcibly stop and restart six minutes later.
- Lock Piston Trip
If stroke is under 5mm even if the current is more than 14Arms, Take it as 'piston lock' and restart after 2'30" of Comp OFF. Check the current and stroke for every 416.7us and if the condition fits more than three times at Comp ON, the Trip occurs.
- IPM fault Trip
It occurs if FO signal received from IPM is LOW. For every 416.7us, check whether FO signal is LOW. The trip occurs if it is found three times during the five periods(83ms).

5. CIRCUIT DIAGRAM

CIRCUIT DIAGRAMS

*EARTH PART, DUCT HEATER, PLUG TYPE AND COMEARTH PART, FUSE ON CIRCUIT DIAGRAM ARE SUBJECT TO CHANGE IN DIFFERENT LOCALITIES AND MODEL TYPE.
 - [] : OPTIONAL

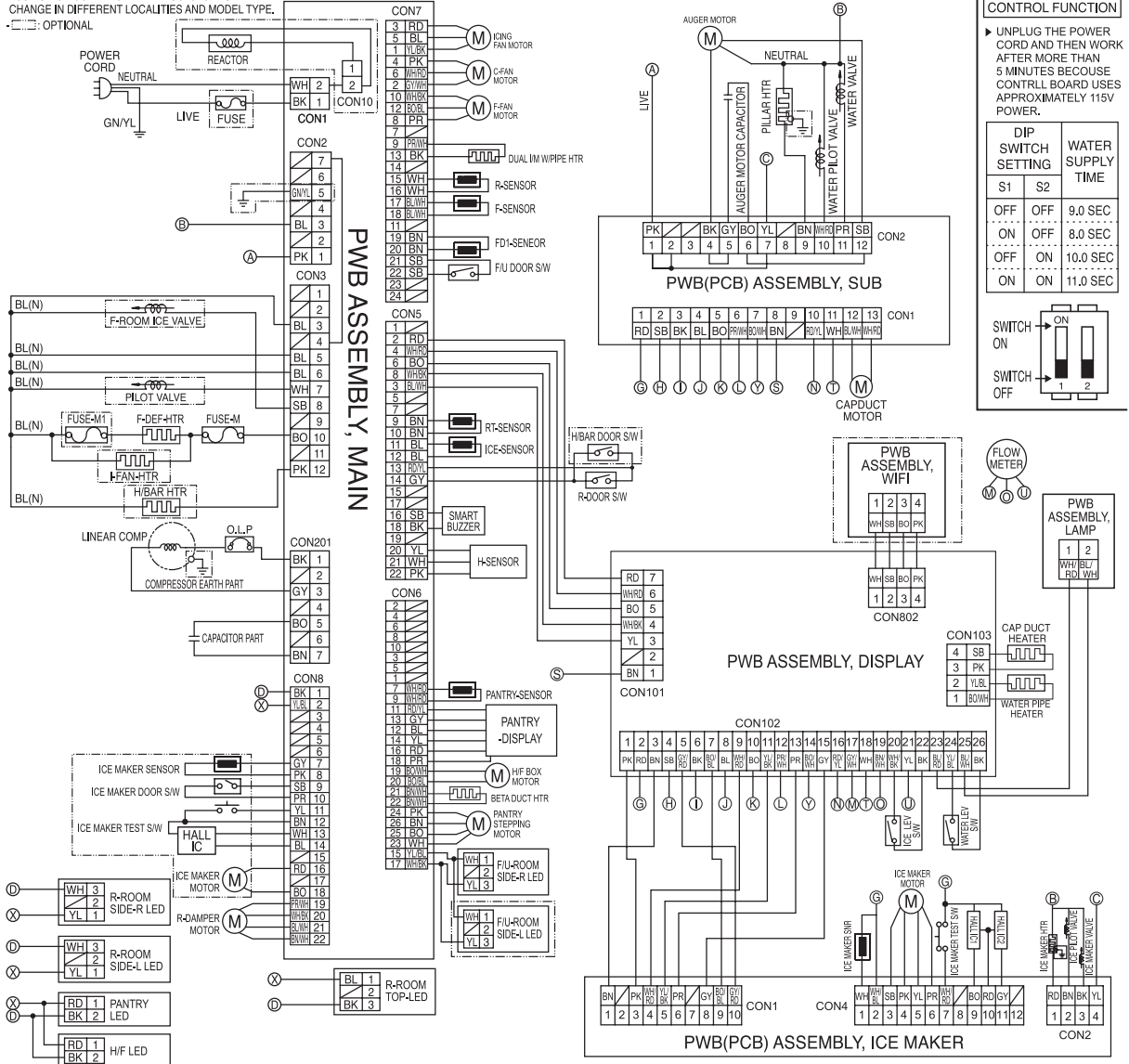

WATER SUPPLY CONTROL FUNCTION

▶ UNPLUG THE POWER CORD AND THEN WORK AFTER MORE THAN 5 MINUTES BECAUSE CONTRLL BOARD USES APPROXIMATELY 115V POWER.

DIP SWITCH SETTING	WATER SUPPLY TIME
S1 OFF, S2 OFF	9.0 SEC
S1 ON, S2 OFF	8.0 SEC
S1 OFF, S2 ON	10.0 SEC
S1 ON, S2 ON	11.0 SEC

SWITCH ON / OFF diagram showing a 2-position switch.

BK(BLACK) : NOIR BL(BLUE) : BLEU BN(BROWN) : MARRON BO(BRIGHT ORANGE) : ORANGE BRILLANT GY(GRAY) : GRIS YL(YELLOW/BLUE) : JAUNE/BLEU WH(WHITE/BLACK) : LANC/NOIR
 YL(YELLOW) : JAUNE RD(RED) : ROUGE GN(GREEN) : VERT BL(WH(BLUE/WHITE)) : BLEU/BLANC WH(WHITE) : BLANC GY(RD(GRAY/RED)) : GRIS/ROUGE RD(WH(WHITE)) : ROUGE/BLANC
 SB(SKY BLUE) : CIEL BLEU PK(PINK) : ROSE GN(YL(GREEN/YELLOW)) : VERT/JAUNE PR(PURPLE) : PURPLE BO(WH(BRIGHT ORANGE/WHITE)) : ORANGE BRILLANT/BLANC
 WH/RD(WHITE/RED) : BLANC/ROUGE BN(WH(BROWN/WHITE)) : MARRON/BLANC RD/YL(RED/YELLOW) : ROUGE/JAUNE
 YL/BK(YELLOW/BLACK) : JAUNE/NOIR PR/WH(PURPLE/WHITE) : VIOLET/BLANC BL/RD(BLUE/RED) : BLEU/ROUGE
 GY/WH(GRAY/WHITE) : GRIS /BLANC BO/BL(BRIGHT ORANGE/BLUE) : ORANGE BRILLANT/BLEU GY/RD(GRAY/RED) : GRIS/ROUGE

6. TROUBLESHOOTING

6-1 Error Code Summary

▲ WARNING: When checking Resistance values, make sure to turn off the power, and wait for the voltage to discharge.

NOTE) Within 3 hours after the error : Press the Ice Plus button and Freezer button simultaneously
All errors except for “E rt”, “E SS”, “E IS(except for icing Sensor)”, “E gF”, “E It”, E HS”, “E Id”, “E IU” error, are displayed.
“E IS” which is displayed without input of user is the error of Icing Sensor.

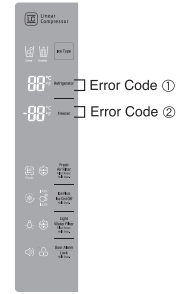

NO	Error Detection Category	Error Display		Error Generation Factors	Remark
		Refrigerator Temperature (Error code ①)	Freezer Temperature (Error code ②)		
1	Normality			None	Normal operation of Display
2	Freezer Sensor Error	E	FS	Short or Disconnection of Freezer Sensor	Check each sensor at it's connector.
3	Refrigerator Sensor Error	E	rS	Short or Disconnection of Refrigerator Sensor	
4	Defrost Sensor Error	E	dS	Short or Disconnection of Pantry Sensor	
5	Humidity Sensor Error	E	HS	Short or Disconnection of Humidity	
6	Freezing Icing Sensor Error	E	Id	Short or Disconnectoin of the sensor about freezer Ice maker	
7	Refrigerator Icing Sensor Error	E	IS	Short or Disconnectoin of the sensor about refrigerator Ice maker	
8	Pantry sensor error	E	SS	Short or Disconnection of Pantry Sensor	
9	Room Temp Sensor Error	E	rt	Short or Disconnectoin of Room temp.sensor	
10	Freezer Ice maker kit defect	E	IU	Other Electric system error such as moter, gear, operation circuit within freezer I/M kit	
11	Refrigerator Ice maker kit defect	E	It	Other Electric system error such as moor, gear, opeation circuit within refrigerator I/M kit	When the ice does not drop even when the refrigerator I/M Test S/W is pressed
12	Flow Meter(Sensor) Defect	E	gF	Error of flow meter or water input or low water pressure	Error of flow meter or water input or low water pressure or flow meter connection
13	Defrosting Error	F	dH	Even though it is passed 80Minute since then Defrosting, if Defrosting sensor is not over 46.4°F(8°C), it is caused	Temperature Fuse Disconnection, Heater disconnection, DRAIN Jam, Poor Relay for Heater
14	Abnormality of BLDC FAN Moter for Ice Making	E	IF	It is caused when feedback signal isn't over 65 seconds during BLDC FAN motor operating	Poor BLDC Motor connection, DRIVE IC, and TR
15	Abnormality of BLDC FAN Moter for Freezer	E	FF	It is caused when feedback signal isn't over 65 seconds during BLDC FAN motor operating	Poor BLDC Motor connection, DRIVE IC, and TR
16	Abnormality of BLDC FAN Moter for Mechanic Room	E	CF	It is caused when feedback signal isn't over 65 seconds during BLDC FAN motor operating	Poor BLDC Motor connection, DRIVE IC, and TR
17	Communication Error	E	CO	Communication Error between Micom of Main PCB and Display Micom	Poor Communication connection,Poor TR of Transmitter and Receiver Tx/Rx between display and main board.

7. PCB Picture

7-1. Main PCB

(P/N : EBR78940502)

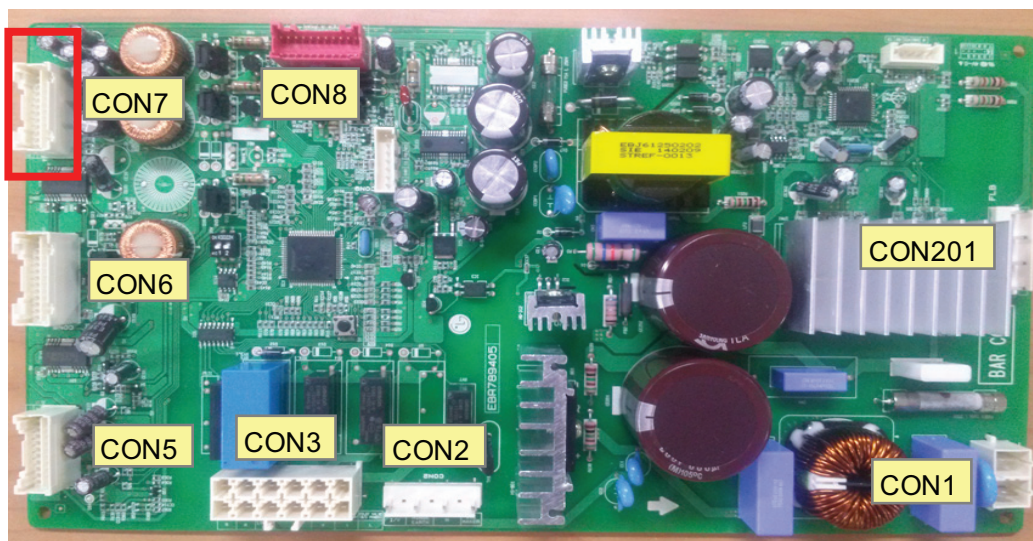

7-2. Display PCB

(P/N : EBR79159704)

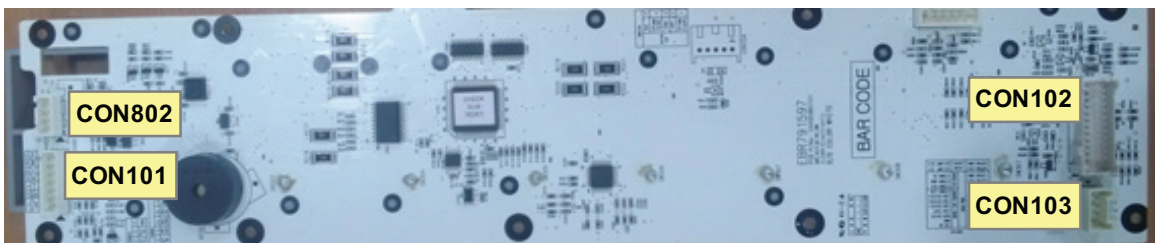

7-3. Sub PCB

(P/N : EBR76468401)

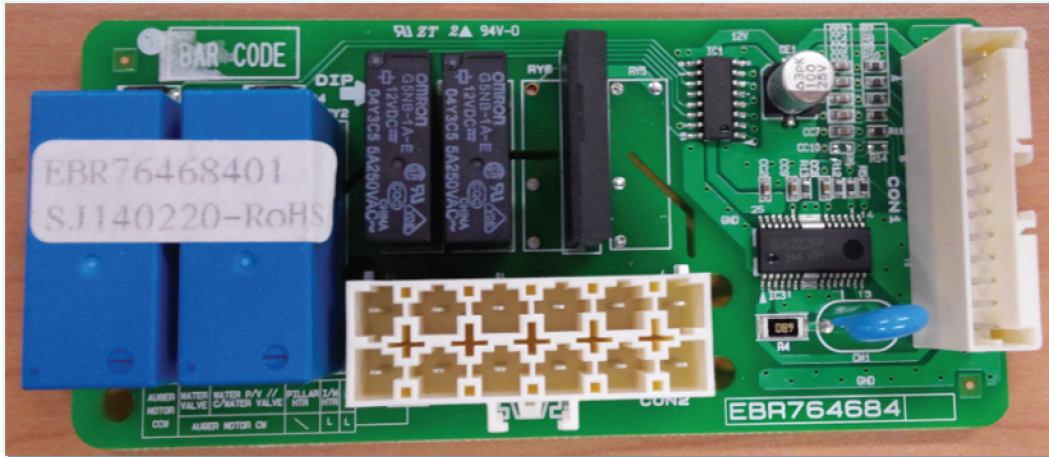

8. Trouble Shooting

8-1. Freezer Sensor Error (Er FS)

Symptom	Check Point
1. Er FS	1. Check for a loose connection 2. Check Sensor Resistance

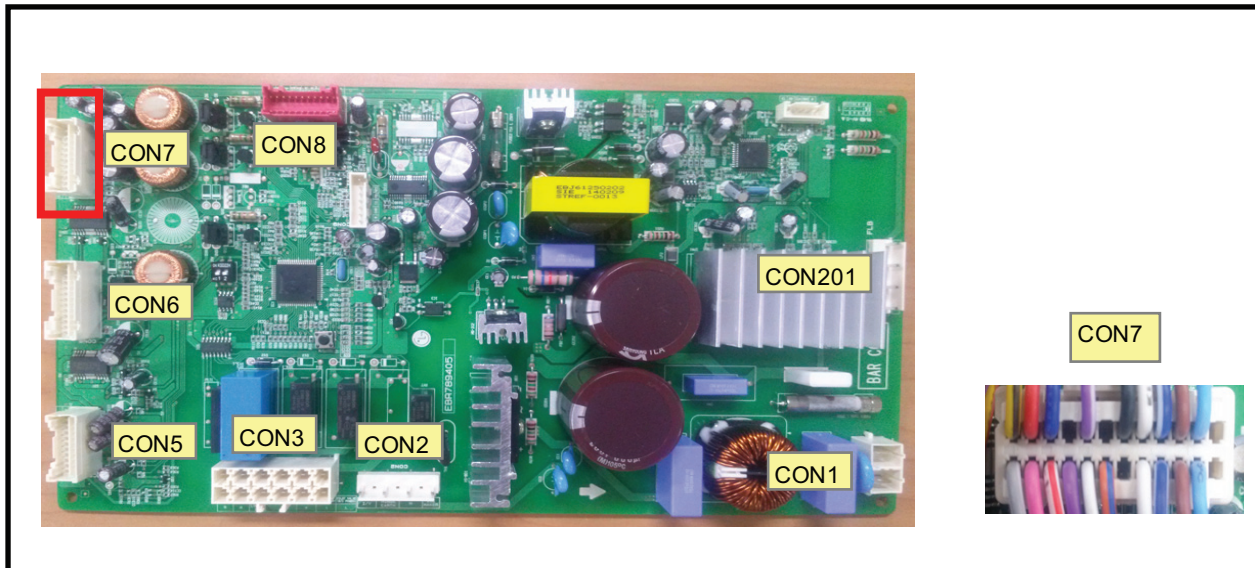

		Resistance [Ω]	
CON7 17 th pin ~ 18 th pin	Short	0	
	Open	OFF	
	Other	Normal	

CON7 17 th pin ~ 18 th pin	Resistance [Ω]
-22°F / -30°C	40k
-13°F / -25°C	30k
-4°F / -20°C	23k
-13°F / -25°C	17k
14°F / -10°C	13k
23°F / -5°C	10k
32°F / 0°C	8k

Pin	Color	Component
3	RD	ICING FAN MOTOR
5	BL	
1	YL/BK	
4	PK	C-FAN MOTOR
6	WH/RD	
2	GY/WH	F-FAN MOTOR
10	WH/BK	
12	BO/BL	
8	PR	DUAL WM W/PIPE HTR
7		
9	PR/WH	R-SENSOR
13	BK	
14		F-SENSOR
15	WH	
16	WH	FD1-SENEOR
17	BL/WH	
18	BL/WH	F/U DOOR S/W
11		
19	BN	
20	BN	
21	SB	
22	SB	
23		
24		

Freezer Sensor Error (Er FS)

1

Is the Connector disconnected or loose between Main PCB and sensor?

Yes → Reconnect or repair the connector

No → [Proceeds to Step 2]

CON7



2

Check the Sensor resistance. Is resistance 0Ω (Sensor short)?

Yes → Change the Sensor

No → [Proceeds to Step 3]

3

Check the Sensor resistance. Is resistance OFF (Sensor open)?

Yes → Replace the refrigerator

No → [Proceeds to Step 4]

4

Check the Sensor resistance. Is resistance normal?

Yes → [Proceeds to Step 5]

5

Check the Temperature and resistance refer to the table. No problem?

CON7 17 th pin ~18 th pin	Resistance [Ω]
-22°F / -30°C	40k
-13°F / -25°C	30k
-4°F / -20°C	23k
-13°F / -25°C	17k
14°F / -10°C	13k
23°F / -5°C	10k
32°F / 0°C	8k

Yes → [Proceeds to Step 6]

6

Explain to customer

8-2. Refrigerator Sensor Error (Er rS)

Symptom	Check Point
1. Er rS	1. Check for a loose connection 2. Check Sensor Resistance

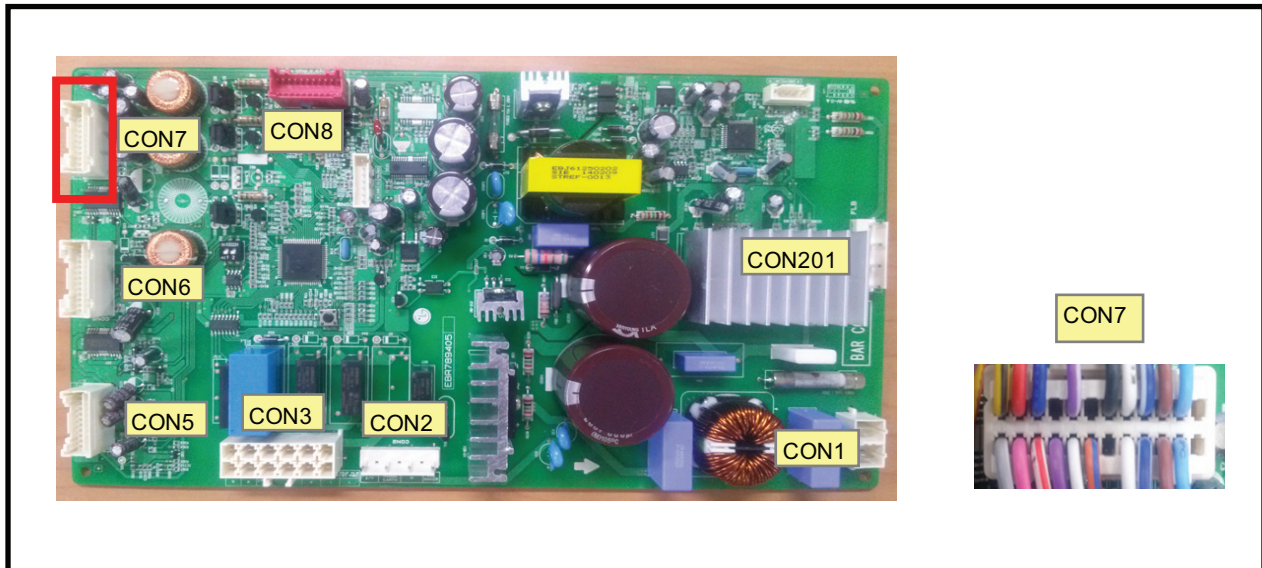

CON7		Resistance [Ω]	
3	RD	Short	0
5	BL	Open	OFF
1	YL/BK		
4	PK	Other	Normal
6	WH/RD		
2	GY/WH		
10	WH/BK		
12	BO/BL		
8	PR		
7			
9	PR/WH		
13	BK		
14			
15	WH	R-SENSOR	
16	WH		
17	BL/WH	F-SENSOR	
18	BL/WH		
11			
19	BN	FD1-SENEOR	
20	BN		
21	SB	F/U DOOR S/W	
22	SB		
23			
24			

CON7		Resistance [Ω]	
15 th pin ~ 16 th pin		23°F / -5°C	38k
		32°F / 0°C	30k
		41°F / 5°C	24k
		50°F / 10°C	19.5k
		59°F / 15°C	16k

Refrigerator Sensor Error (Er rS)

1

Is the Connector disconnected or loose between Main PCB and sensor?

Yes → Reconnect or repair the connector

CON7



No → [Next Step]

2

Check the Sensor resistance. Is resistance 0Ω (Sensor short)?

Yes → Change the Sensor

No → [Next Step]

3

Check the Sensor resistance. Is resistance OFF (Sensor open)?

Yes → Replace the refrigerator

No → [Next Step]

4

Check the Sensor resistance. Is resistance normal?

Yes → [Next Step]

5

Check the Temperature and resistance refer to the table. No problem?

CON7 15 th pin ~ 16 th pin	Resistance [Ω]
23°F / -5°C	38k
32°F / 0°C	30k
41°F / 5°C	24k
50°F / 10°C	19.5k
59°F / 15°C	16k

Yes → [Next Step]

6

Explain to customer

8-3. Icing Sensor Error (Er IS)

Symptom	Check Point
1. Er IS	1. Check for a loose connection 2. Check Sensor Resistance

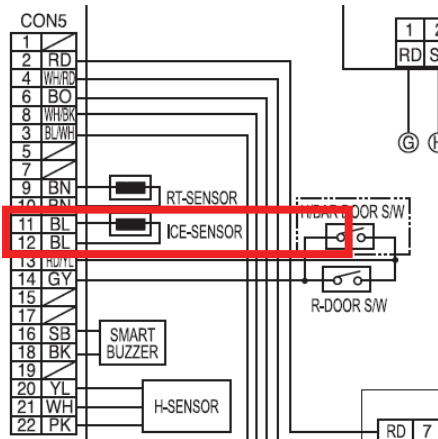
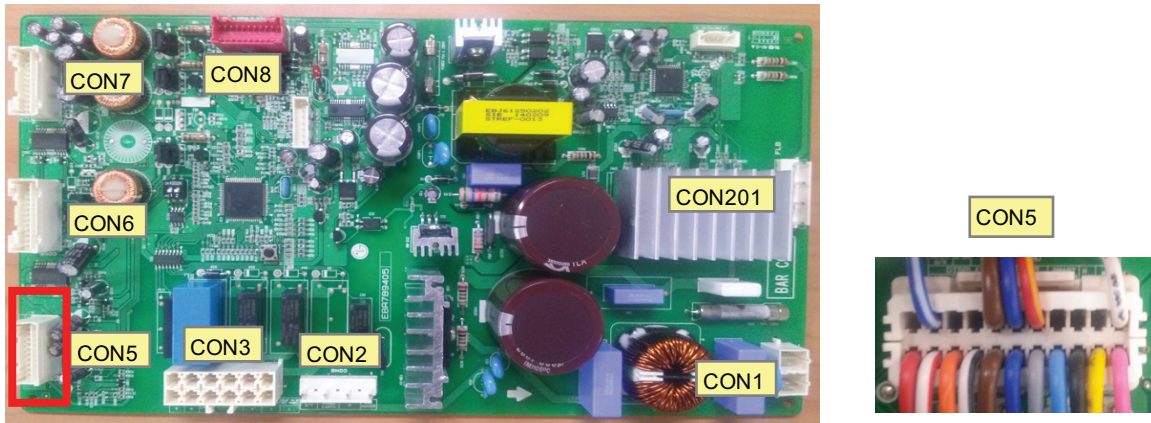

	Resistance [Ω]	
	CON5 11 th pin ~ 12 th pin	Short
	Open	OFF
	Other	Normal

CON5 11 th pin ~ 12 th pin	Resistance [Ω]
-22°F / -30°C	40k
-13°F / -25°C	30k
-4°F / -20°C	23k
-13°F / -25°C	17k
14°F / -10°C	13k
23°F / -5°C	10k
32°F / 0°C	8k

Icing Sensor Error (Er IS)

1
Is the Connector disconnected or loose between Main PCB and sensor?

Yes → Reconnect or repair the connector

CON5



No → [Proceeds to Step 2]

2
Check the Sensor resistance. Is resistance 0Ω (Sensor short)?

Yes → Change the Sensor

No → [Proceeds to Step 3]

3
Check the Sensor resistance. Is resistance OFF (Sensor open)?

Yes → Replace the refrigerator

No → [Proceeds to Step 4]

4
Check the Sensor resistance. Is resistance normal?

Yes → [Proceeds to Step 5]

5
Check the Temperature and resistance refer to the table. No problem?

CON5 11 th pin ~ 12 th pin	Resistance [Ω]
-22°F / -30°C	40k
-13°F / -25°C	30k
-4°F / -20°C	23k
-13°F / -25°C	17k
14°F / -10°C	13k
23°F / -5°C	10k
32°F / 0°C	8k

Yes → [Proceeds to Step 6]

6
Explain to customer

8-4. Defrost Sensor Error (F dS)

Symptom	Check Point
1. F dS	1. Check for a loose connection 2. Check Sensor Resistance

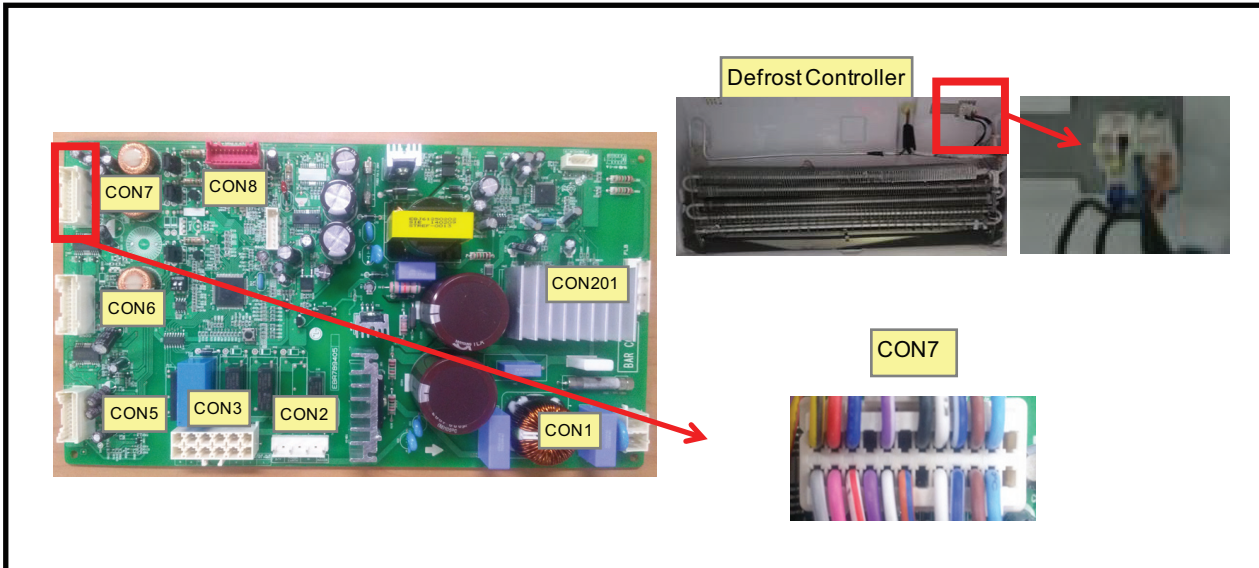

		Resistance [Ω]	
CON7 19 th pin ~ 20 th pin	Short	0	
	Open	OFF	
	Other	Normal	

CON7 19 th pin ~ 20 th pin	Resistance [Ω]
23°F / -5°C	38k
32°F / 0°C	30k
41°F / 5°C	24k
50°F / 10°C	19.5k
59°F / 15°C	16k

Pin	Color	Component
3	RD	ICING FAN MOTOR
5	BL	
1	YL/BK	
4	PK	C-FAN MOTOR
6	WH/RD	
2	GY/WH	F-FAN MOTOR
10	WH/BK	
12	BO/BL	
8	PR	RD-SENSOR
9	RD/YL	
13	GY	R-SENSOR
14	GY	
15	WH	F-SENSOR
16	WH	
17	BL/WH	DRAIN HTR
18	BL/WH	
7	YL	FD-SENSOR
11	YL	
19	BN	F/U DOOR SW
20	R/WH	
21	SB	
22	SB	
23		
24		

Defrost Sensor Error (F dS)

1

Is the Connector disconnected or loose between Main PCB, Defrost controller and Sensor?

Yes → Reconnect or repair the connector

No → [Proceeds to Step 2]

CON7



2

Check the Sensor resistance. Is resistance 0Ω (Sensor short)?

Yes → Change the Sensor

No → [Proceeds to Step 3]

3

Check the Sensor resistance. Is resistance OFF (Sensor open)?

Yes → Replace the refrigerator

No → [Proceeds to Step 4]

4

Check the Sensor resistance. Is resistance normal?

Yes → [Proceeds to Step 5]

5

Check the Temperature and resistance refer to the table. No problem?

CON7 19 th pin ~ 20 th pin	Resistance [Ω]
23°F / -5°C	38k
32°F / 0°C	30k
41°F / 5°C	24k
50°F / 10°C	19.5k
59°F / 15°C	16k

Yes → [Proceeds to Step 6]

6

Explain to customer

8-5. Defrost Heater Error (F dH)

Symptom	Check Point
1. F dH	<ol style="list-style-type: none"> 1. Check the door gasket 2. Check Defrost Heater 3. Check the PCB output voltage

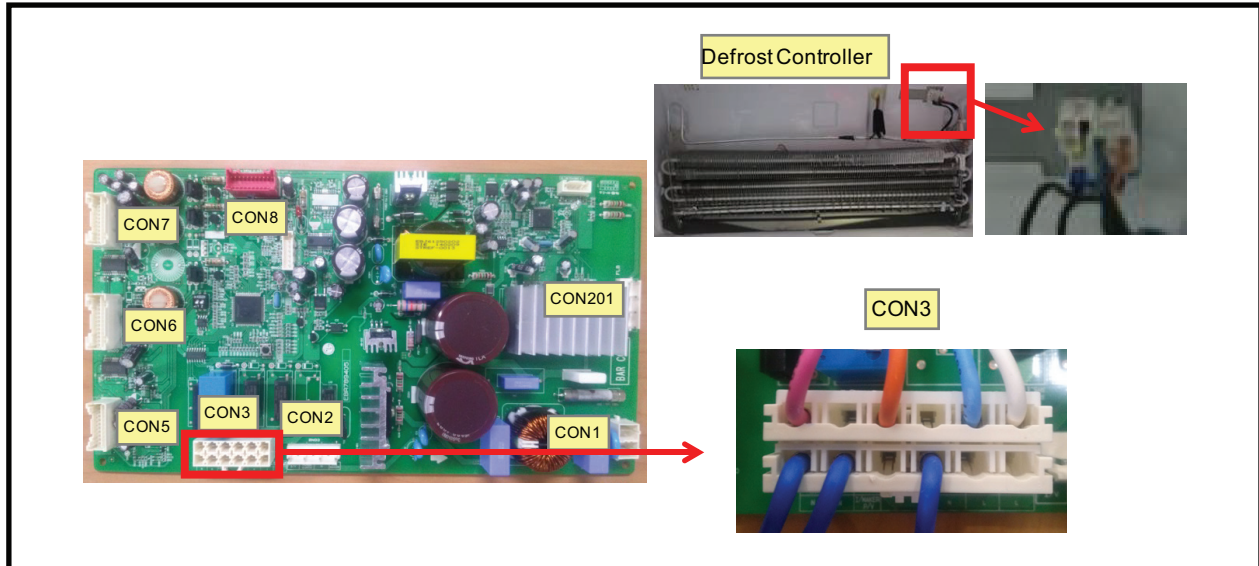

Part	Resistance [Ω]
FUSE-M	0
Defrost Heater	35~40
Defrost Sensor	22k \uparrow

TEST MODE 3	Voltage [V]
CON3 6 th pin ~ 10 th pin	112V ~ 116V

TEST MODE 1	Voltage [V]
CON3 6 th pin ~ 10 th pin	0V

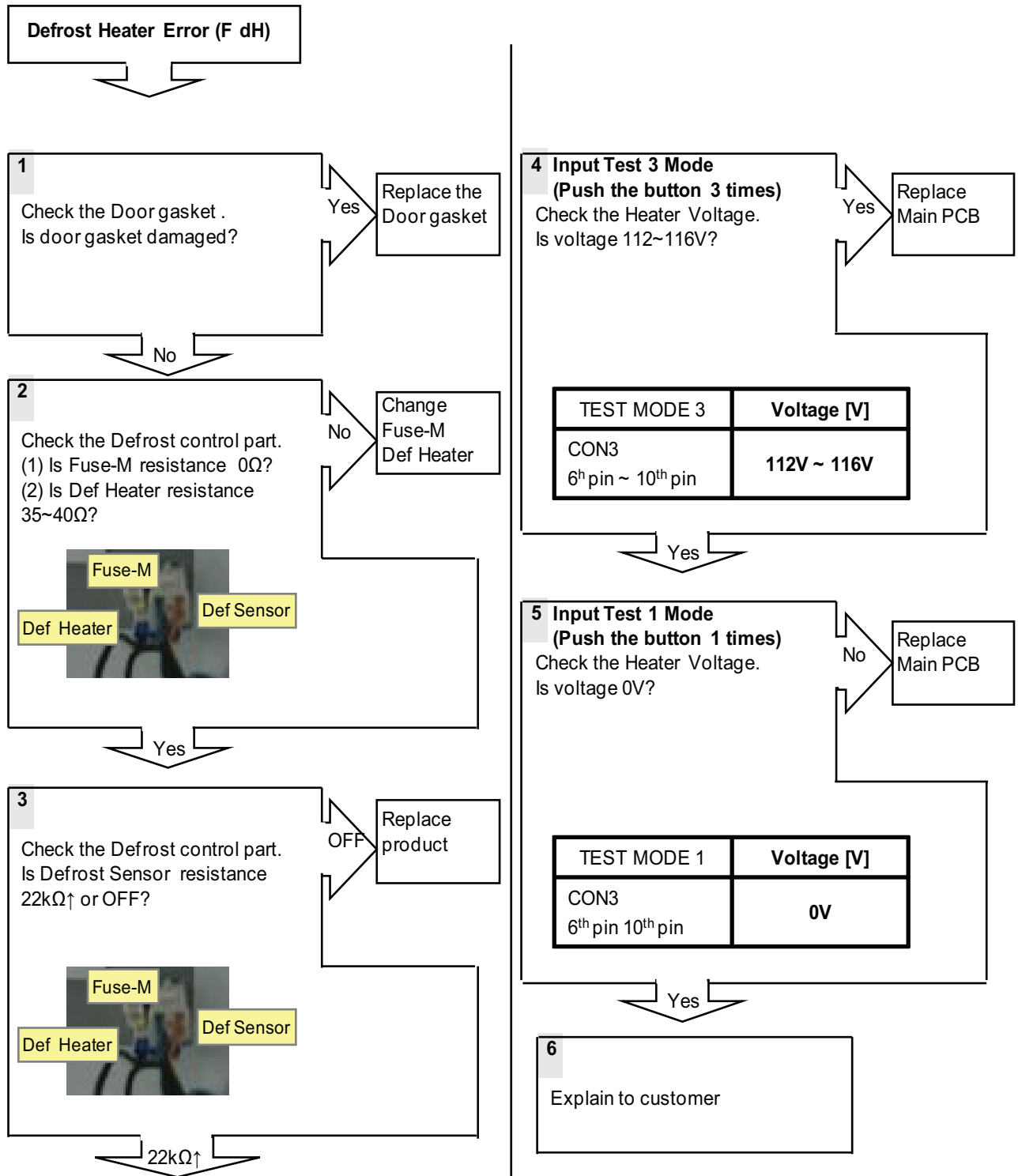

8-6. Freezer Fan Error (Er FF)

Symptom	Check Point
1. Er FF	1. Check the air flow 2. Check the Fan Motor 2. Check the PCB Fan motor voltage

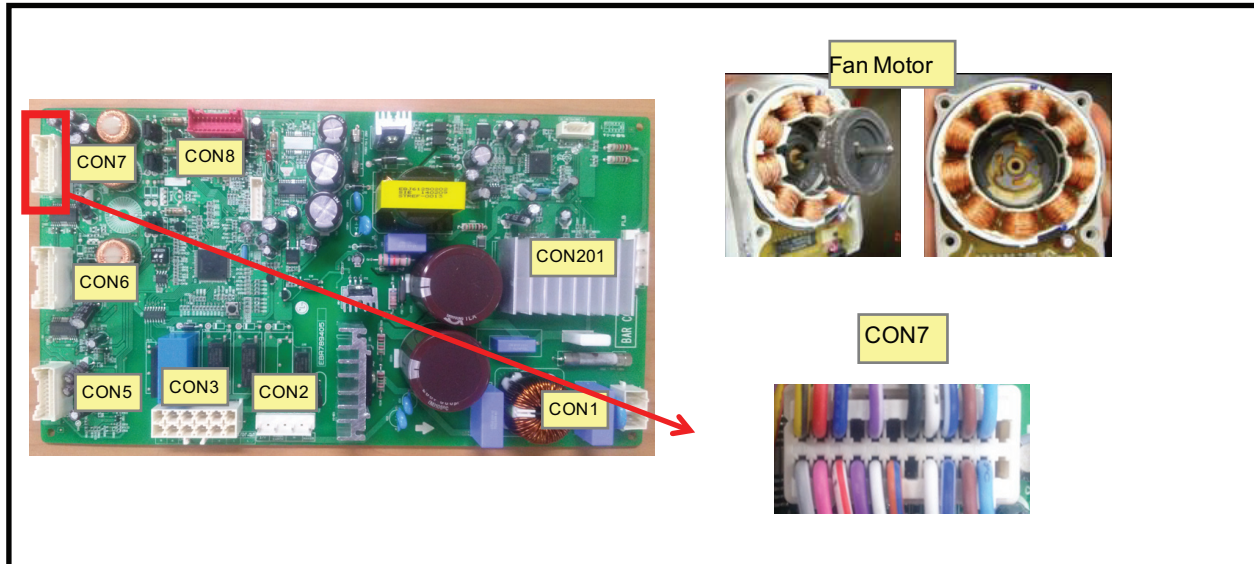

TEST MODE 1	Voltage [V]
CON7 10 th pin ~ 12 th pin	8~12V
CON7 8 th pin ~ 12 th pin	Not 0V, 5V

CON7	
3 RD	ICING FAN MOTOR
5 BL	
1 YL/BK	
4 PK	C-FAN MOTOR
6 WH/RD	
2 GY/WH	
10 WH/BK	F-FAN MOTOR
12 BO/BL	
8 PR	
9 PR/WH	
13 BK	DUAL IM W/PIPE HTR
14	
15 WH	R-SENSOR
16 WH	
17 BL/WH	F-SENSOR
18 BL/WH	
11	
19 BN	FD1-SENEOR
20 BN	
21 SB	F/U DOOR S/W
22 SB	
23	
24	

Freezer Fan Error (Er FF)

1 Reset the unit and Input Test1 Mode. (Push the button 1 time)

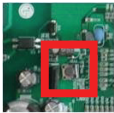

2 Open the freezer door and Check the air flow. Windy?



Yes
Go to 4

3 Check the Fan motor. Rotate fan using hand. It feel sticky?

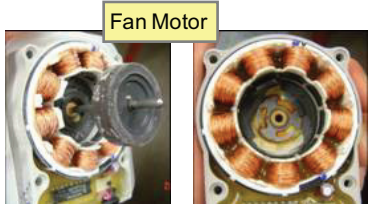

Yes
Change the Fan motor

4 Check the Fan Motor voltage Is Fan Motor voltage 8~12V?

TEST MODE 1	Voltage [V]
CON7 10 ^h pin ~ 12 th pin	8~12V

No
Replace Main PCB

Yes

5 Check the Fan Motor voltage Is Fan Feed Back voltage 0V, 5V?

TEST MODE 1	Voltage [V]
CON7 8 th pin ~ 12 th pin	Not 0V, 5V

Yes
Change the motor

No

6 Explain to customer

8-7. Icing Fan Error (Er IF)

Symptom	Check Point
1. Er IF	1. Check the air flow 2. Check the Connector 2. Check the PCB Fan motor voltage

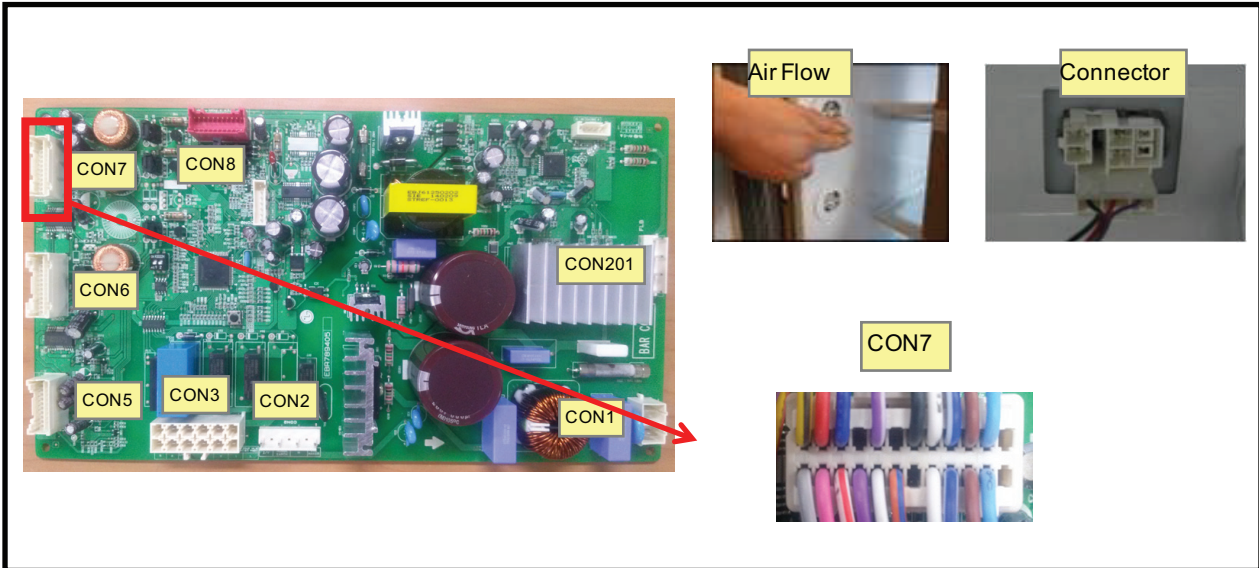

CON7	
3	RD
5	BL
1	YL/BK
4	PK
6	WH/RD
2	GY/WH
10	WH/BK
12	BO/BL
8	PR
7	
9	PR/WH
13	BK
14	
15	WH
16	WH
17	BL/WH
18	BL/WH
11	
19	BN
20	BN
21	SB
22	SB
23	
24	

TEST MODE 1	Voltage [V]
CON7 3 rd pin ~ 5 th pin	8~12V
CON7 1 st pin ~ 5 th pin	Not 0V, 5V

Freezer Fan Error (Er IF)

1 Reset the unit and Input Test1 Mode. (Push the button 1 time)

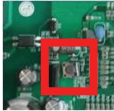

2 Open the freezer door and Check the air flow. Windy?



Yes
Go to 4

3 Check the Fan motor. Rotate fan using hand. It feel sticky?

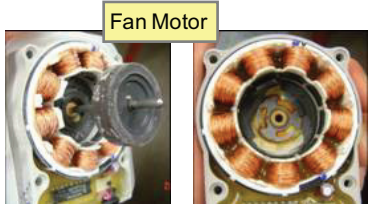

Yes
Change the Fan motor

4 Check the Fan Motor voltage Is Fan Motor voltage 8~12V?

TEST MODE 1	Voltage [V]
CON7 3 rd pin ~ 5 th pin	8~12V

No
Replace Main PCB

Yes

5 Check the Fan Motor voltage Is Fan Feed Back voltage 0V, 5V?

TEST MODE 1	Voltage [V]
CON7 1 st pin ~ 5 th pin	Not 0V, 5V

Yes
Change the motor

No

6 Explain to customer

8-8. Condenser Fan Error (Er CF)

Symptom	Check Point
1. Er CF	1. Check the air flow 2. Check the Connector 2. Check the PCB Fan motor voltage

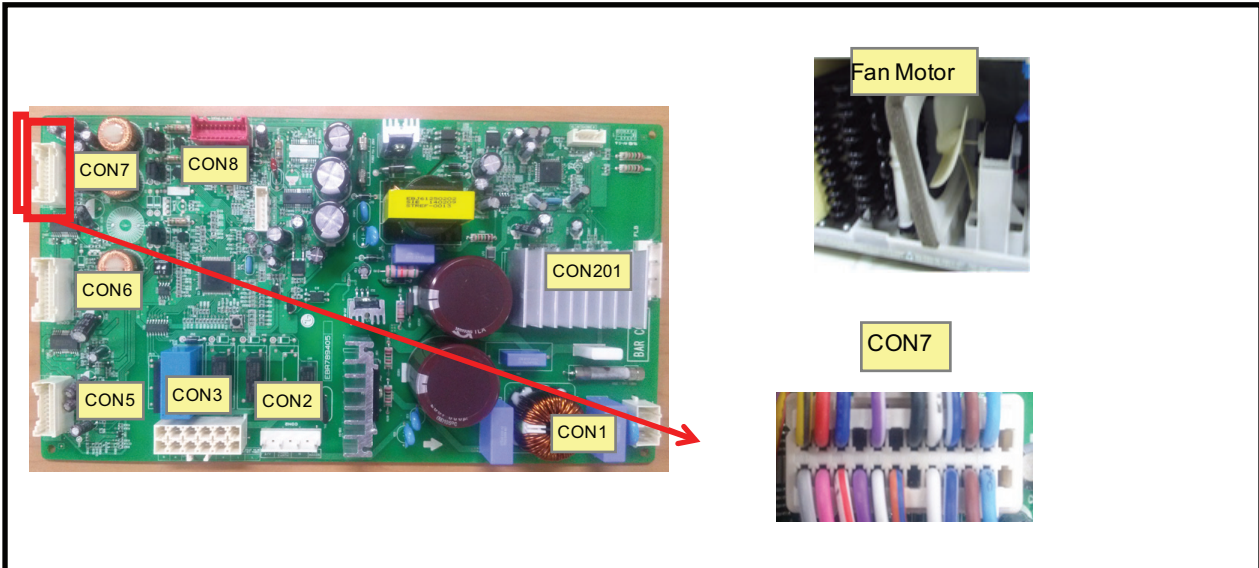

TEST MODE 1	Voltage [V]
CON7 4 th pin ~ 6 th pin	8~12V
CON7 2 nd pin ~ 6 th pin	Not 0V, 5V

CON7	Color	Component
3	RD	ICING FAN MOTOR
5	BL	
1	YL/BK	
4	PK	C-FAN MOTOR
6	WH/RD	
2	GY/WH	
10	WH/BK	F-FAN MOTOR
12	BO/BL	
8	PR	
7		
9	PR/WH	DUAL 1/4 W/PIPE HTR
13	BK	
14		
15	WH	R-SENSOR
16	WH	
17	BL/WH	F-SENSOR
18	BL/WH	
11		
19	BN	FD1-SENEOR
20	BN	
21	SB	F/U DOOR S/W
22	SB	
23		
24		

Condenser Fan Error (Er CF)

1 Reset the unit and Input Test1 Mode. (Push the button 1 time)

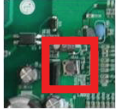

2 Check the fan rotating. Does fan rotate?

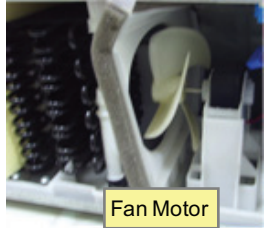

Yes
Go to 4

3 Check the Fan motor. Rotate fan using hand. It feel sticky?

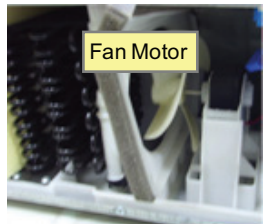

Yes
Change the Fan motor

4 Check the Fan Motor voltage Is Fan Motor voltage 8~12V?

No
Replace Main PCB

TEST MODE 1	Voltage [V]
CON7 4 th pin ~6 th pin	8~12V

Yes

5 Check the Fan Motor voltage Is Fan Feed Back voltage 0V, 5V?

Yes
Change the motor

TEST MODE 1	Voltage [V]
CON7 2 th pin ~6 th pin	Not 0V, 5V

No

6
Explain to customer

8-9. Communication Error (Er CO)

Symptom	Check Point
1. Er CO	1. Check the loose connection 2. Check the Hinge connection

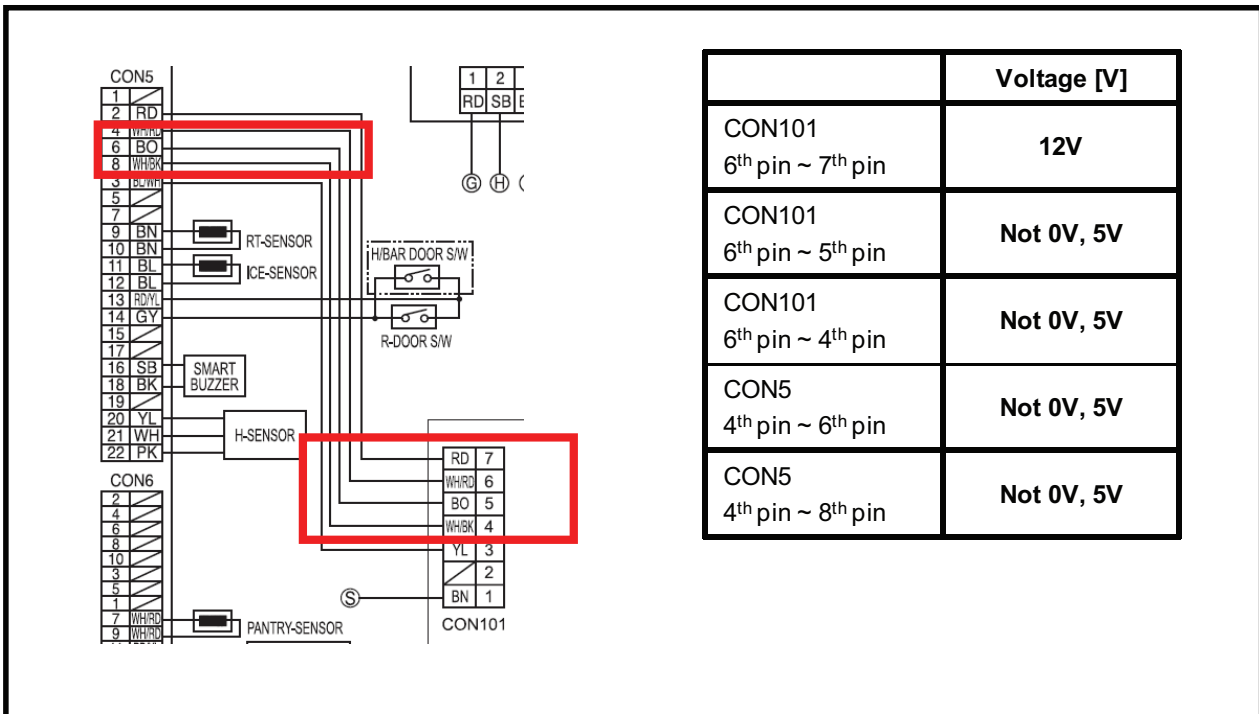
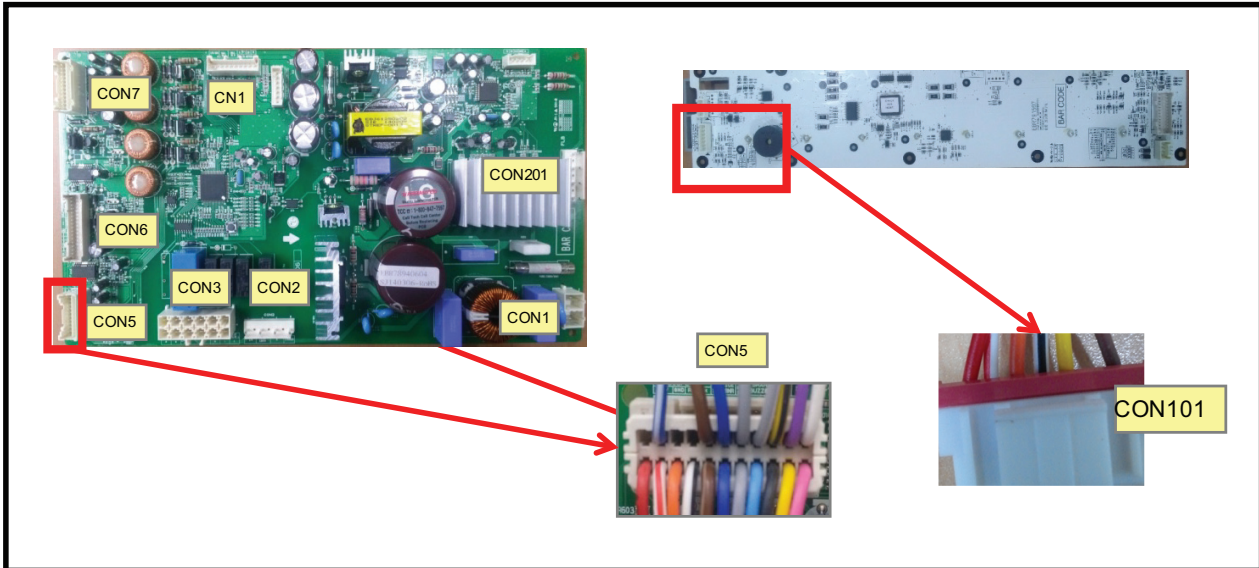

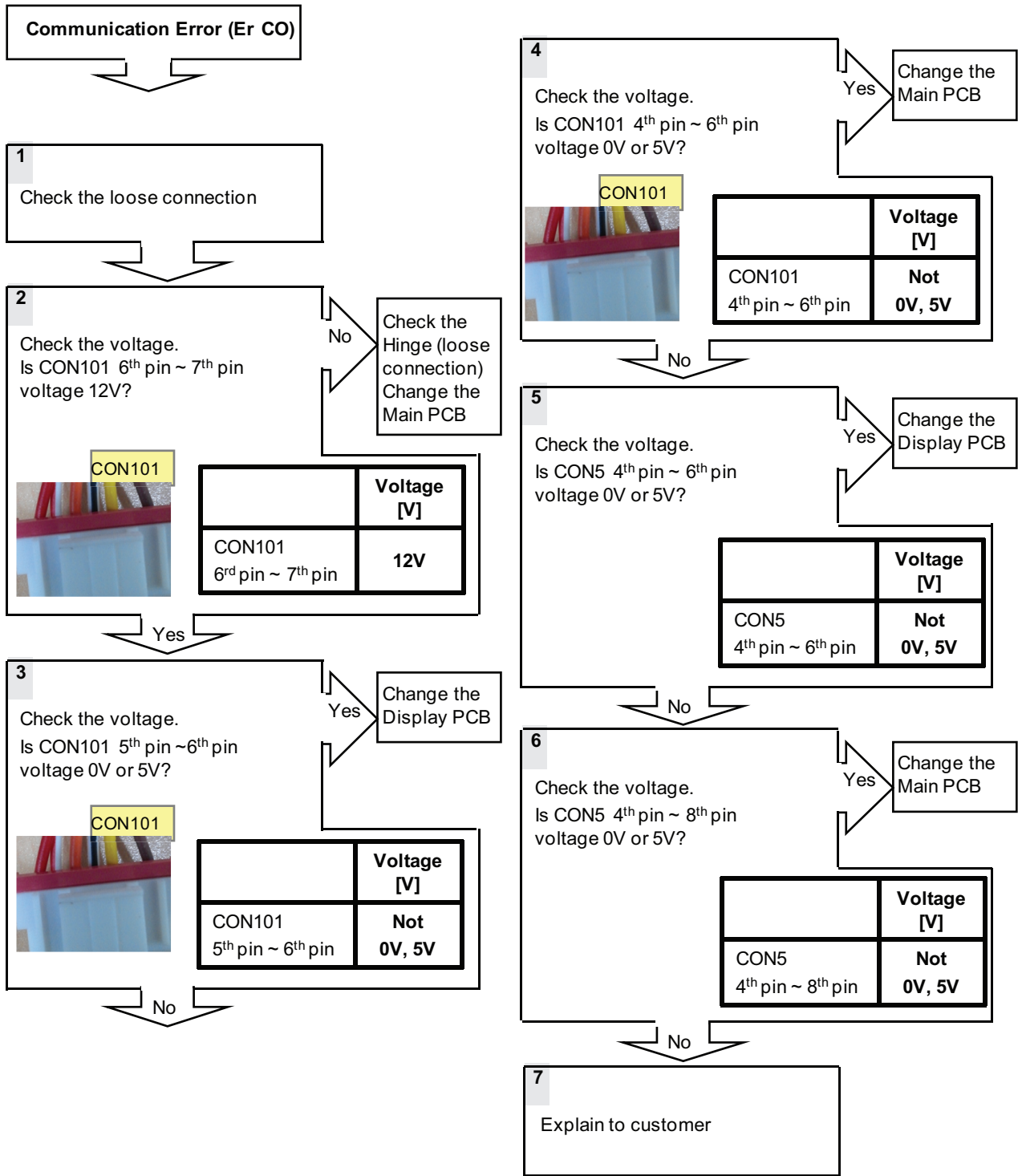

8-10. Cube mode doesn't work

Symptom	Check Point
1. Cube mode doesn't work	1. Check the loose connection 2. Check the resistance

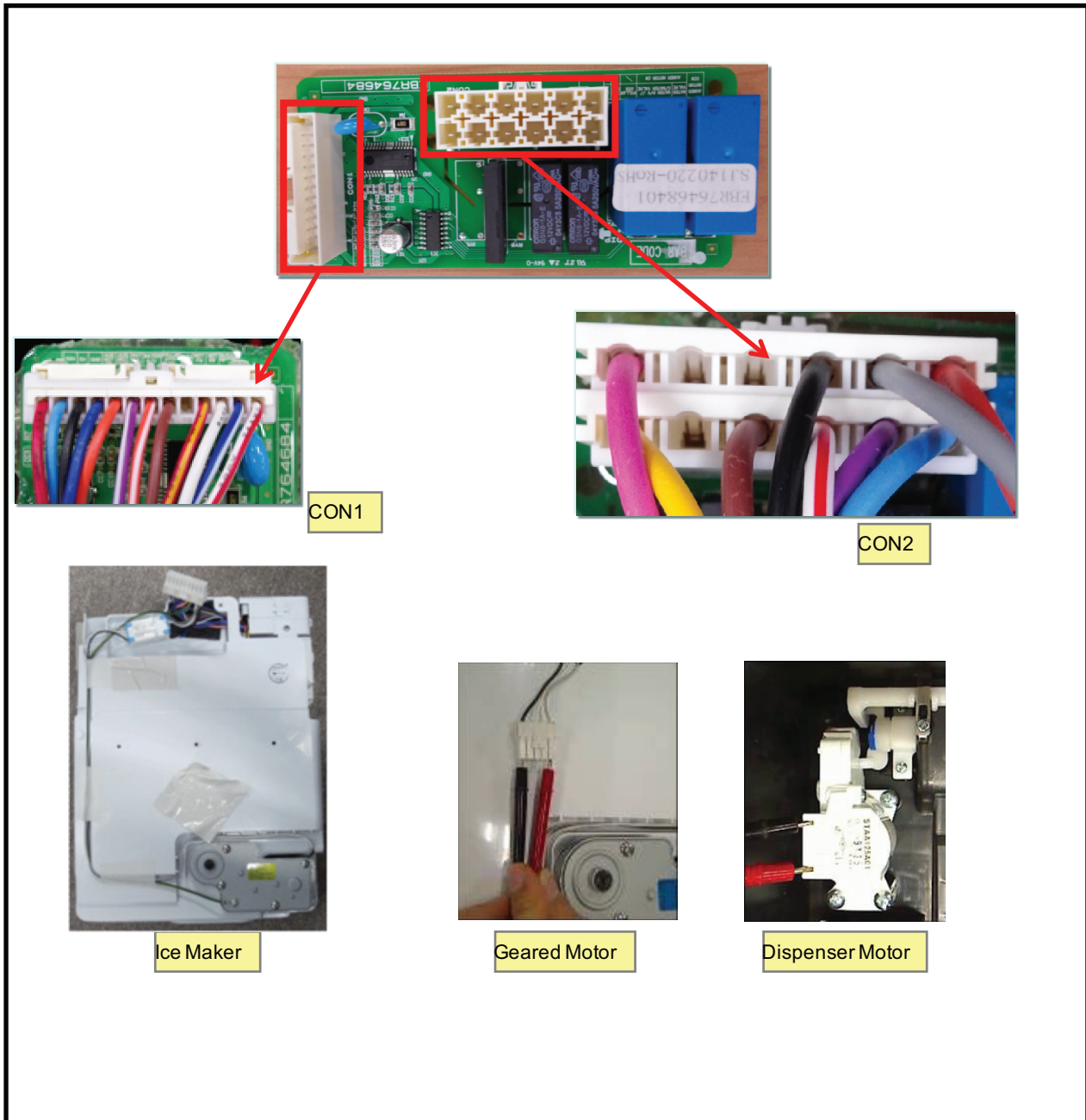

8-10. Cube mode doesn't work

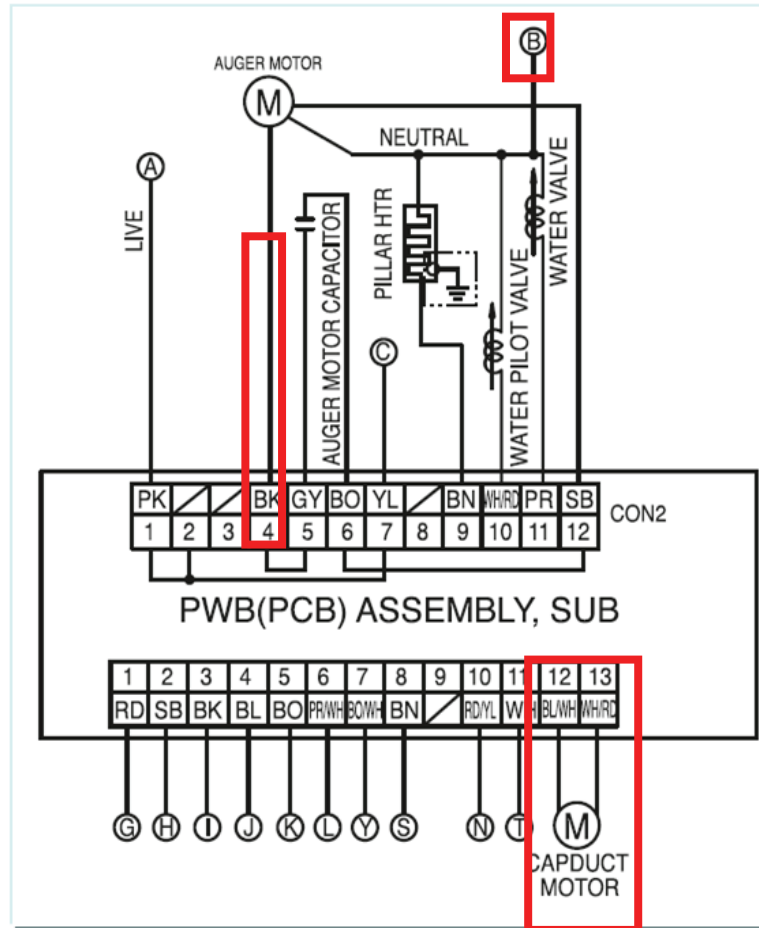

LEVER S/W	Voltage [V]	
CON2 4 th pin ~ B(NEUTRAL)	Pushing	112~115V
	Not Pushing	0~2V
CON1 12 th pin ~ 13 th pin	Pushing	9~12V
	Not Pushing	0~2V

	Resistance [Ω]
Geared Motor	31.1 ~ 42.1
Dispenser Motor	9.9 ~ 12.1

Cube mode doesn't work

1
Check the loose connection

2
Check the voltage.
(while pushing the lever S/W)
Is voltage correct?

No → Change the PCB



LEVER S/W	Voltage [V]	
CON2 4 th pin ~ B(NEUTRAL)	Pushing	112~115V
	Not Pushing	0~2V

Yes →

3
Check the voltage.
(while pushing the lever S/W)
Is voltage correct compared with table?

No → Change the PCB



LEVER S/W	Voltage [V]	
CON1 12 th pin ~ 13 th pin	Pushing	9~12V
	Not Pushing	0~2V

Yes →

4
Check the resistance value.
Is Geared Motor resistance
31.1 ~ 42.1Ω?

No → Replace Geared Motor

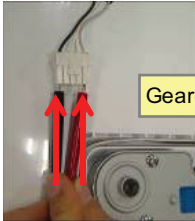

	Resistance [Ω]
Geared Motor	31.1 ~ 42.1

Yes →

5
Check the resistance value.
Is Dispenser Motor resistance
9.9 ~ 12.1Ω?

No → Replace Geared Motor

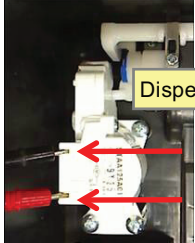

	Resistance [Ω]
Dispenser Motor	9.9 ~ 12.1

Yes →

6
Explain to customer

8-11. Crush mode doesn't work

Symptom	Check Point
1. Cube mode doesn't work	1. Check the loose connection 2. Check the resistance

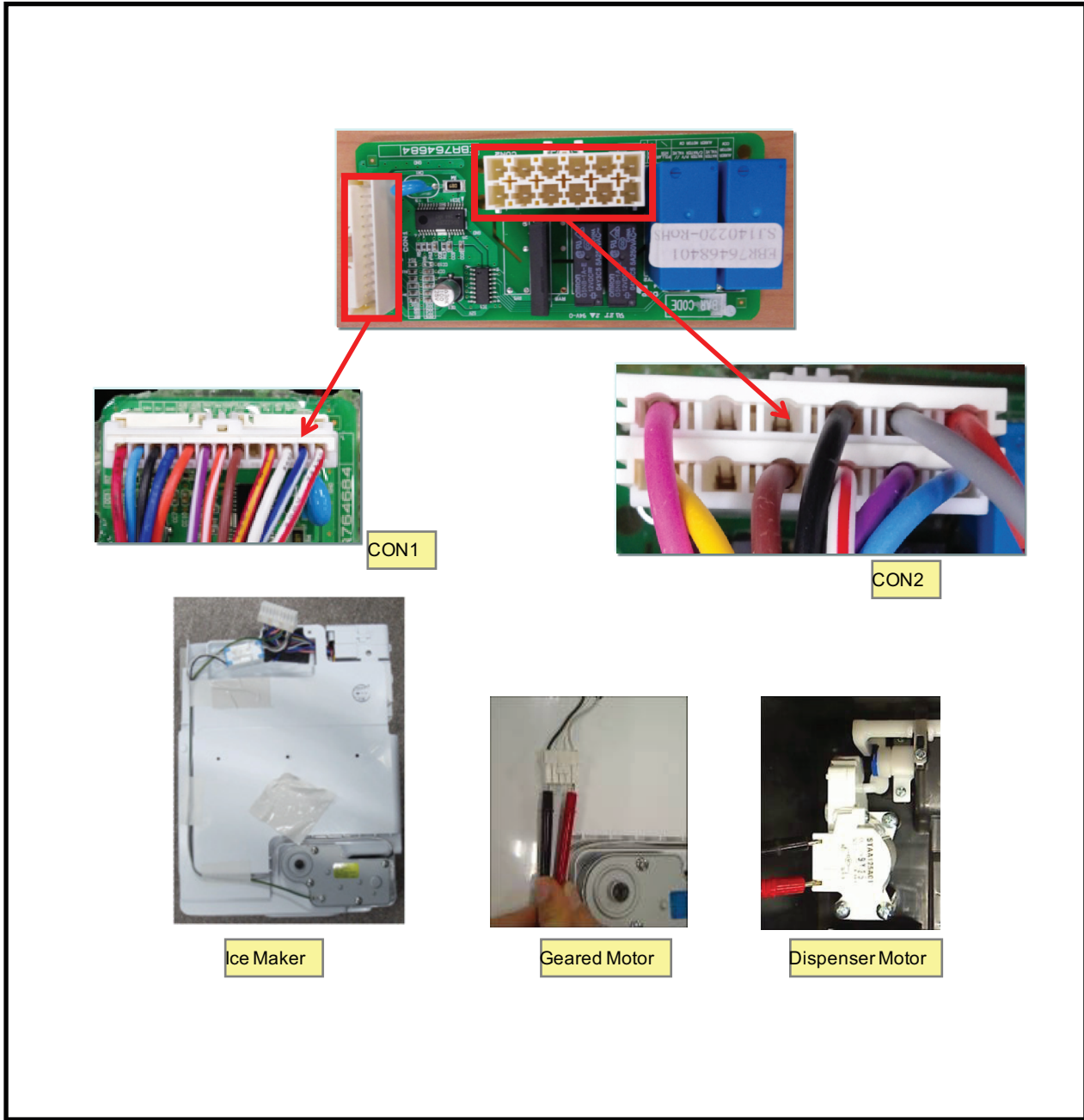

8-11. Crush mode doesn't work

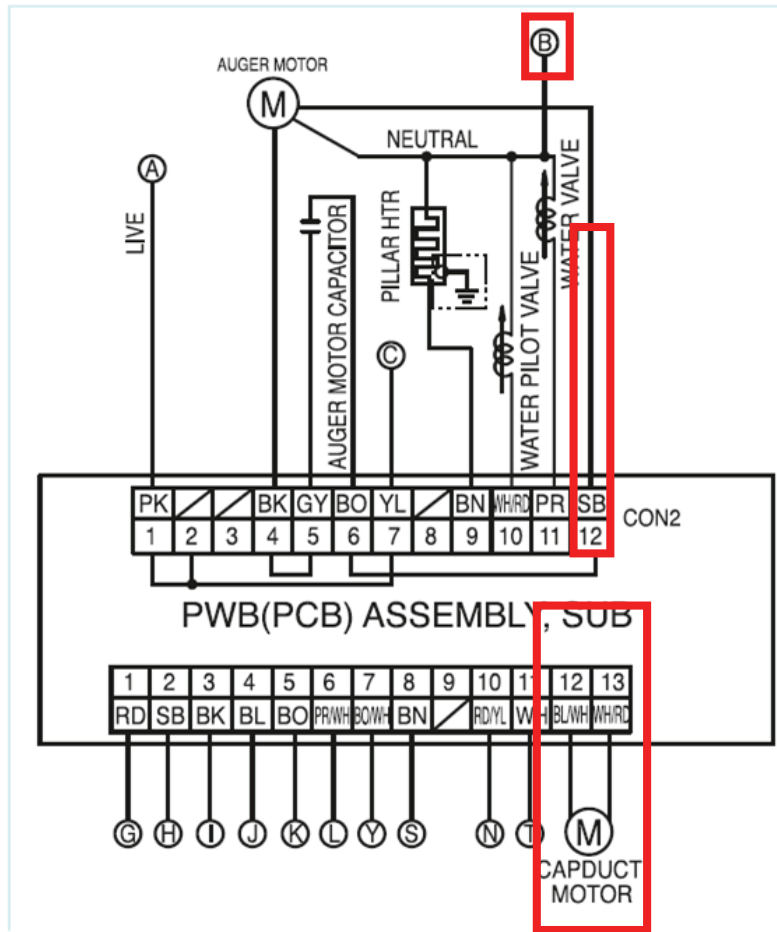

LEVER S/W	Voltage [V]	
CON2 12 th pin ~ B(NEUTRAL)	Pushing	112~115V
	Not Pushing	0~2V
CON1 12 th pin ~ 13 th pin	Pushing	9~12V
	Not Pushing	0~2V

	Resistance [Ω]
Geared Motor	31.1 ~ 42.1
Dispenser Motor	9.9 ~ 12.1

Crush mode doesn't work

1
Check the loose connection

2
Check the voltage.
(while pushing the lever S/W)
Is voltage correct?

No → Change the PCB



LEVER S/W	Voltage [V]	
CON2 12 th pin ~ B(NEUTRAL)	Pushing	112~115V
	Not Pushing	0~2V

Yes →

3
Check the voltage.
(while pushing the lever S/W)
Is voltage correct compared with table?

No → Change the PCB



LEVER S/W	Voltage [V]	
CON1 12 th pin ~ 13 th pin	Pushing	9~12V
	Not Pushing	0~2V

Yes →

4
Check the resistance value.
Is Geared Motor resistance
31.1 ~ 42.1Ω?

No → Replace Geared Motor

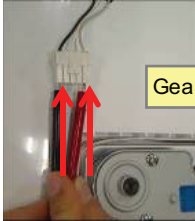

	Resistance [Ω]
Geared Motor	31.1 ~ 42.1

Yes →

5
Check the resistance value.
Is Dispenser Motor resistance
9.9 ~ 12.1Ω?

No → Replace Geared Motor

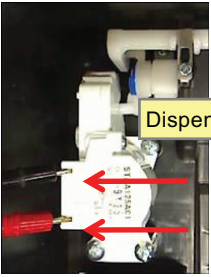

	Resistance [Ω]
Dispenser Motor	9.9 ~ 12.1

Yes →

6
Explain to customer

8-12. Water mode doesn't work

Symptom	Check Point
1. Water mode doesn't work	1. Check the loose connection 2. Check the resistance valve

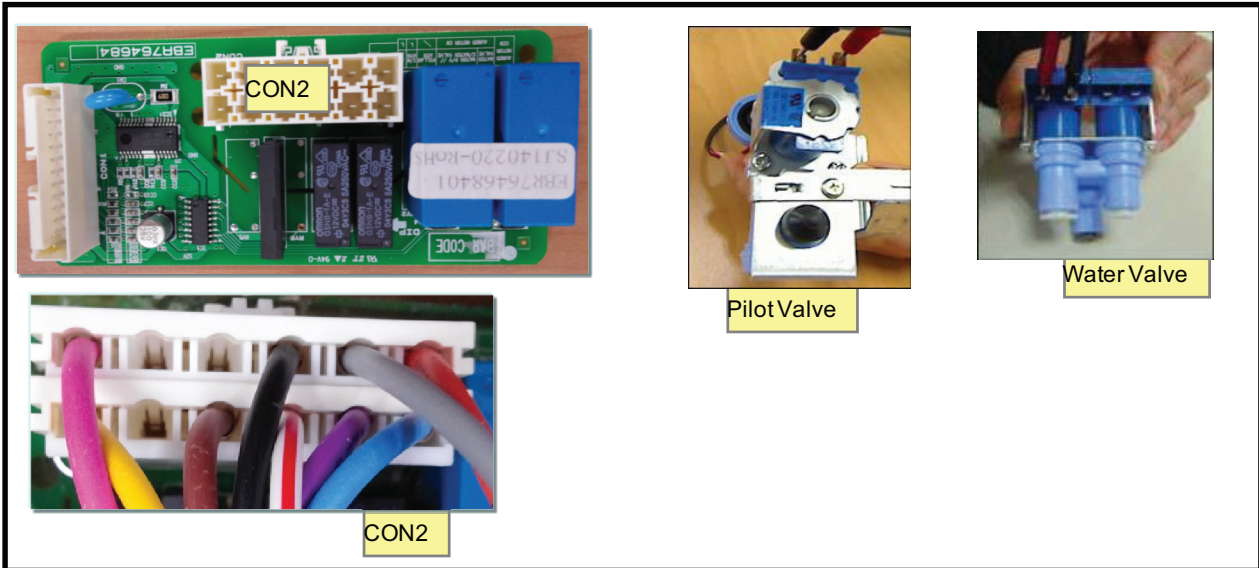

LEVER S/W	Voltage [V]	
	CON2 11 th pin ~ B(NEUTRAL)	Pushing
	Not Pushing	0~2V
CON2 10 th pin ~ B(NEUTRAL)	Pushing	112~115V
	Not Pushing	0~2V

	Resistance [Ω]
Pilot Valve	360~420
Water valve	360~420

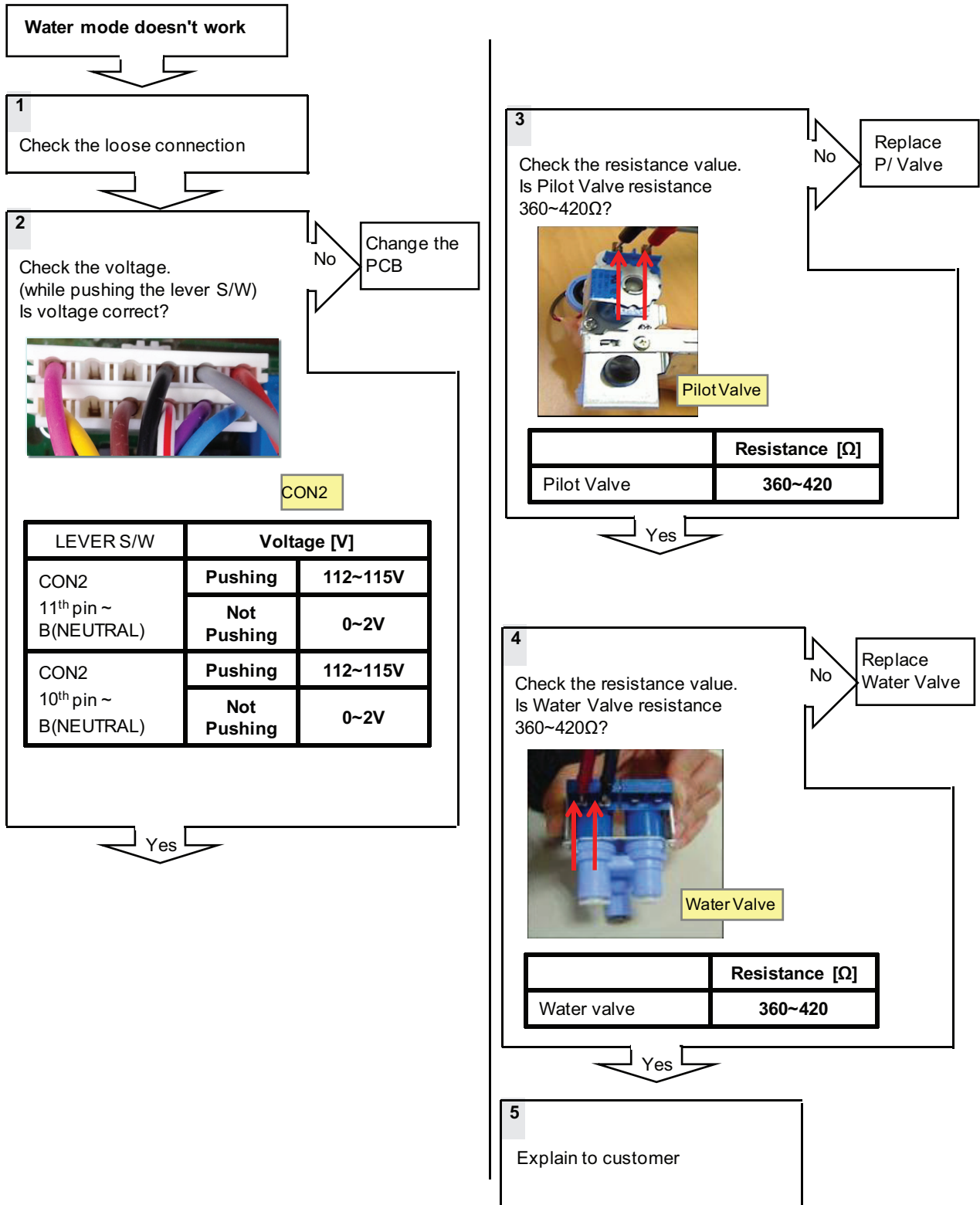

8-13. Freezer room lamp doesn't work

Symptom	Check Point
1. Freezer room lamp doesn't work	1. Check the freezer door switch sticky 2. Check the door S/W resistance 3. Check the LED Lamp

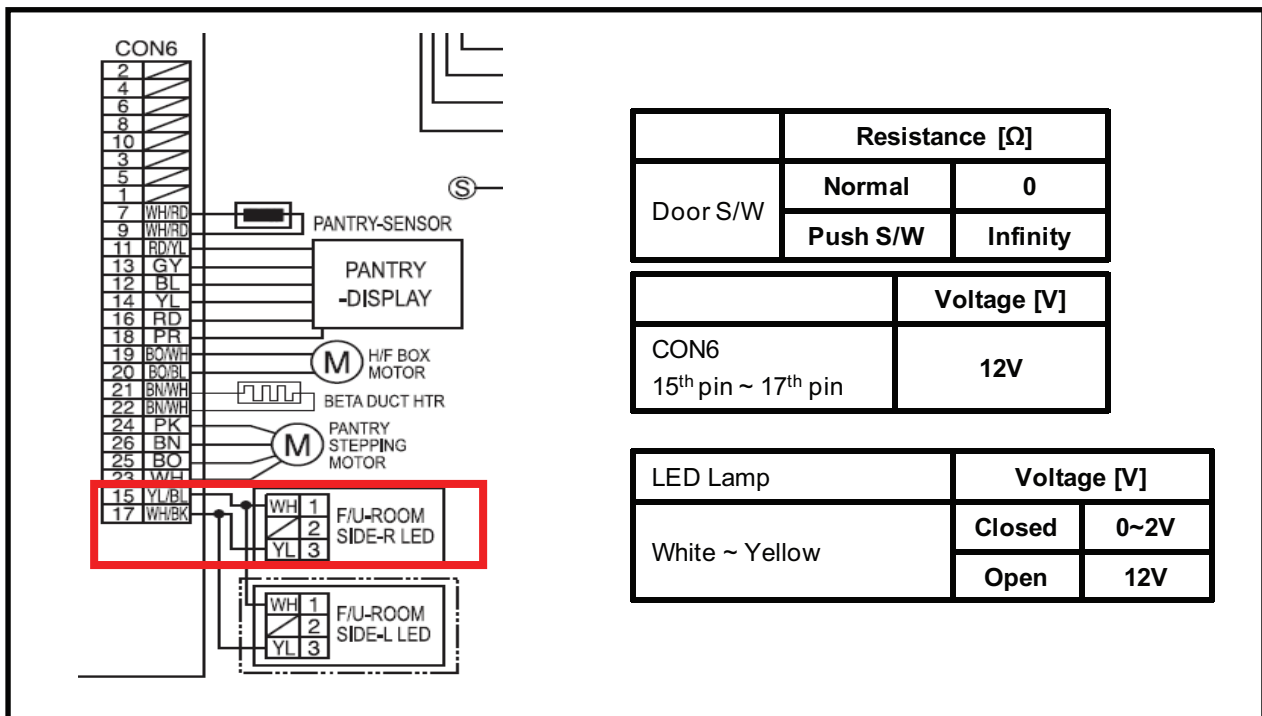
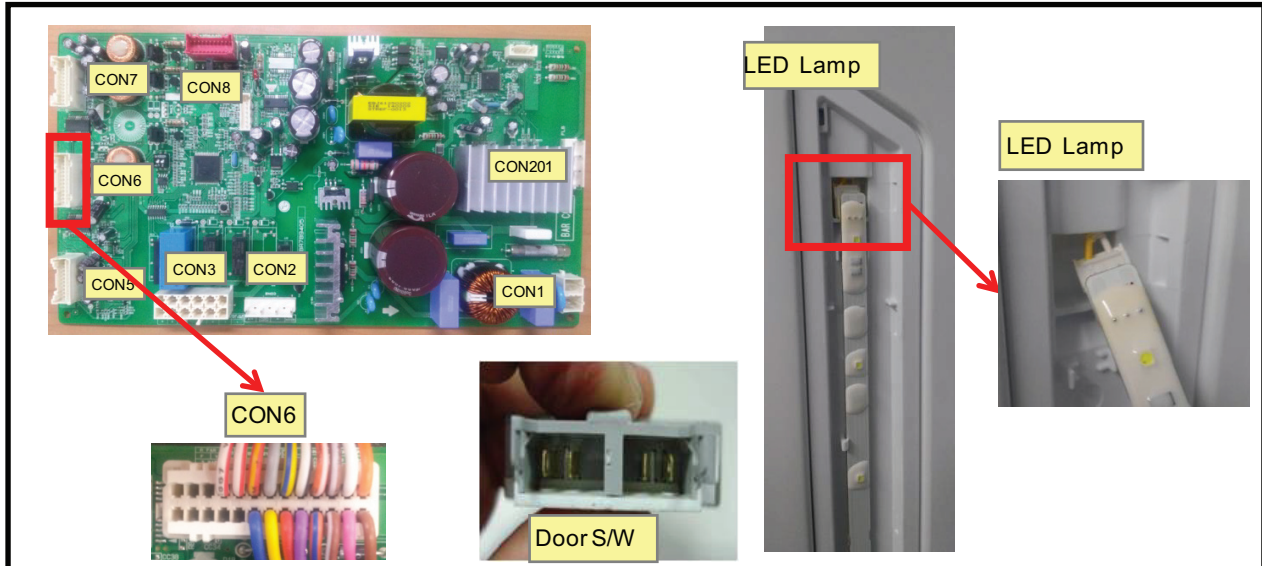

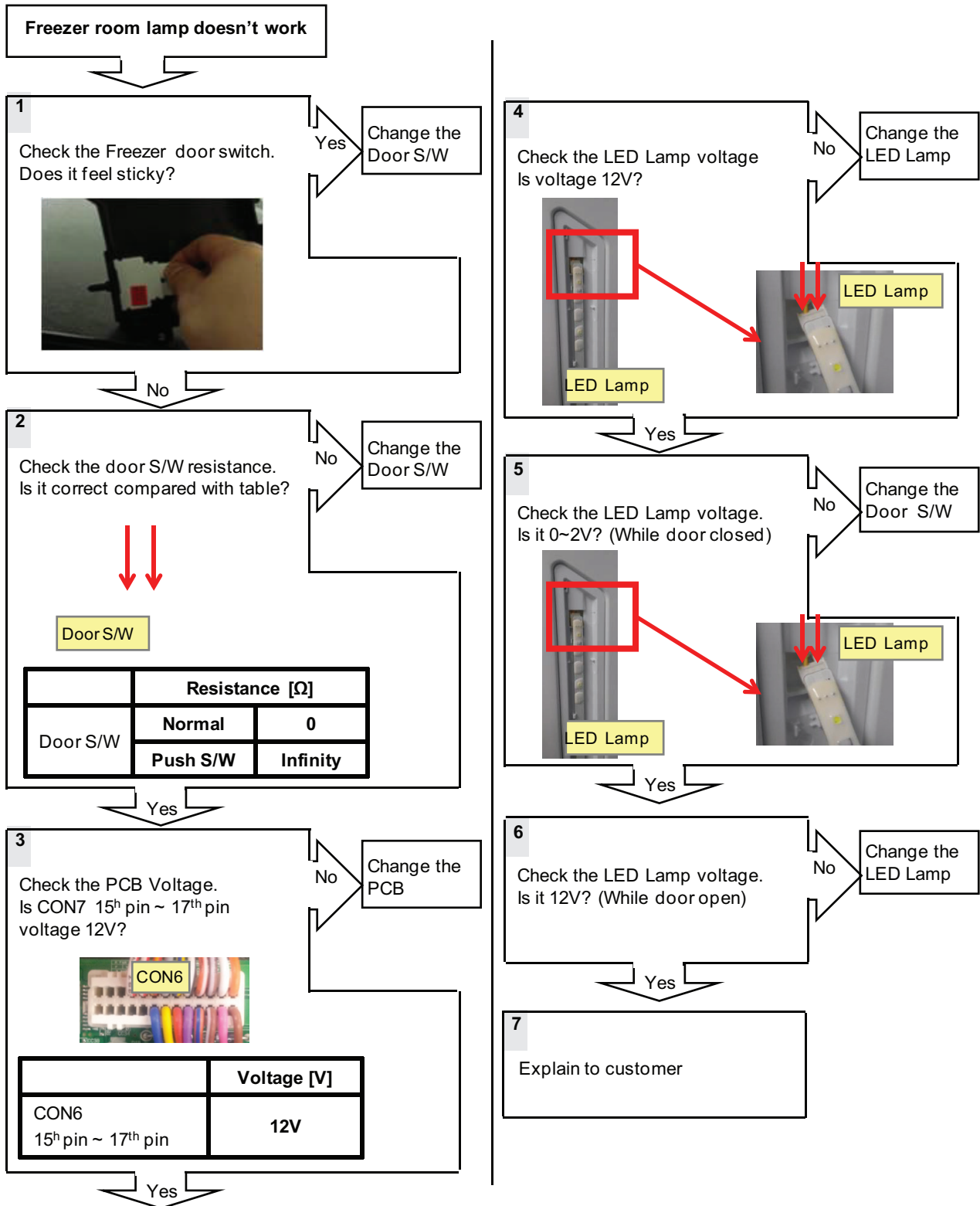

8-14. Refrigerator room lamp doesn't work

Symptom	Check Point
1. Refrigerator room lamp doesn't work	1. Check the Refrigerator door switch sticky 2. Check the door S/W resistance 3. Check the LED Lamp

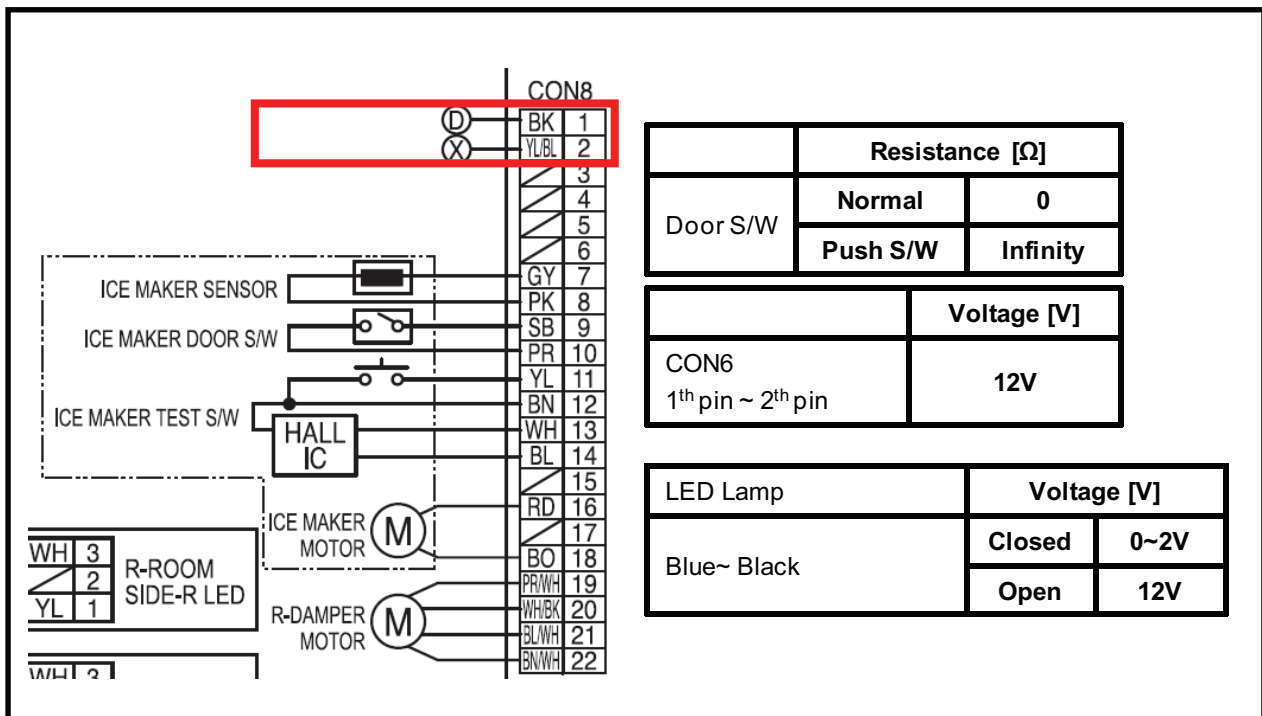
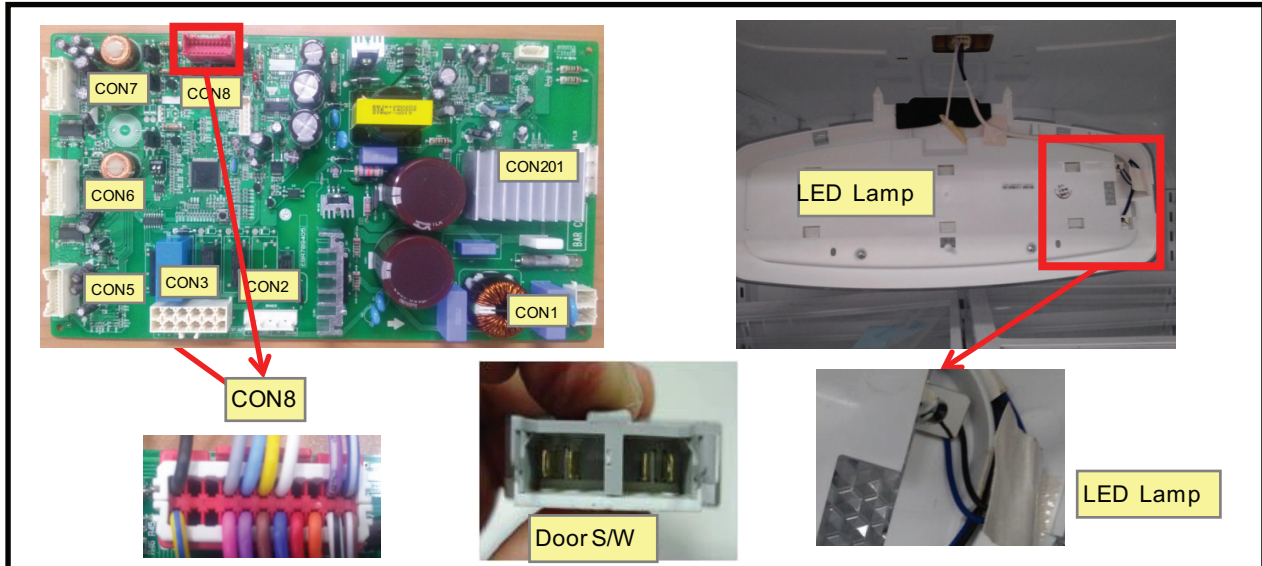

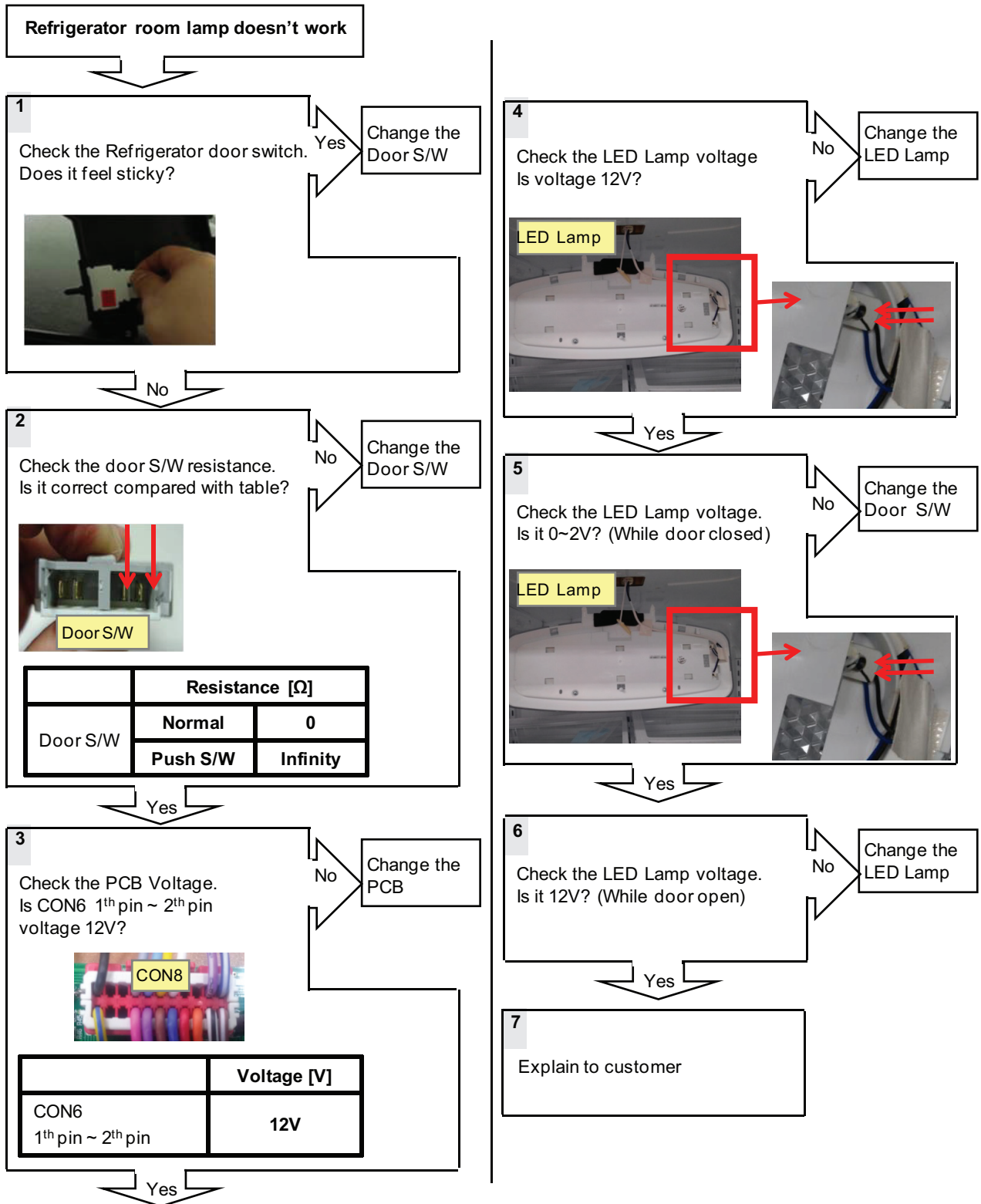

8-15. Poor cooling in Fresh food section

Symptom	Check Point
1. Poor cooling in Fresh food section	1. Check the sensor resistance 2. Check the air flow 3. Check the air Temperature 4. Check the R-Damper voltage 5. Check the F-Fan

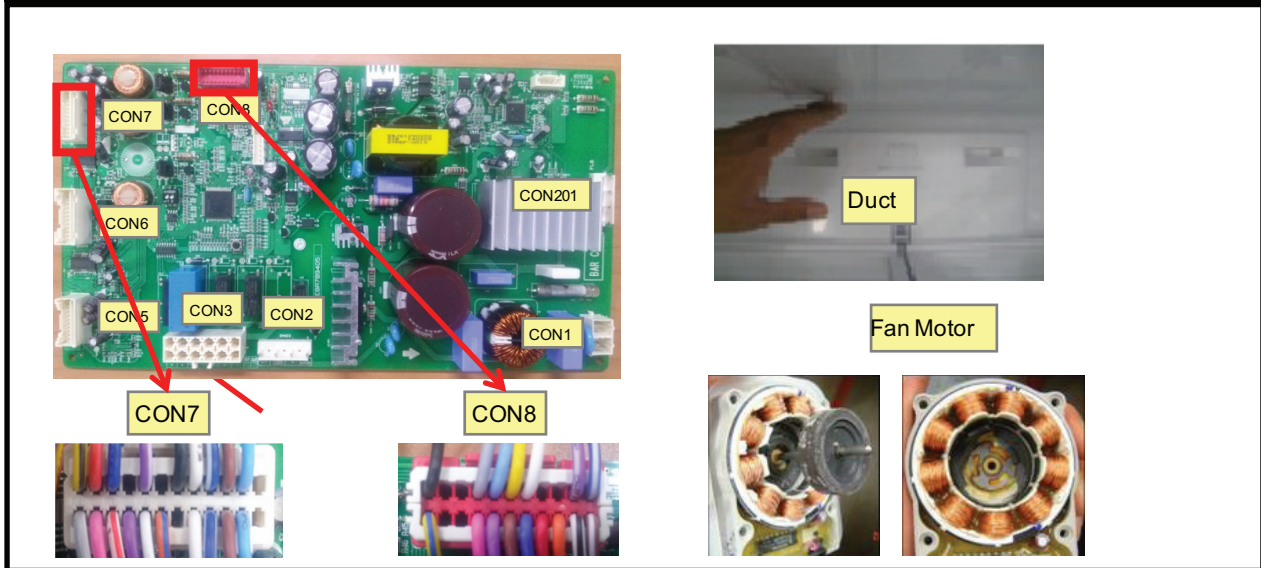

The wiring diagram shows the connections for CON7 and CON8. CON7 pins 10, 12, and 16 are highlighted with red boxes. CON8 pins 19, 20, and 21 are highlighted with red boxes. The diagram includes components like the R-DAMPER MOTOR, F-FAN MOTOR, C-FAN MOTOR, R-SENSOR, and F-SENSOR.

CON7 15 th pin ~ 16 th pin	Resistance [Ω]
23°F / -5°C	38k
32°F / 0°C	30k
41°F / 5°C	24k
50°F / 10°C	19.5k
59°F / 15°C	16k

CON8	Resistance [Ω]
19 th pin ~ 21 th pin	270 ~330 Ω
20 st pin ~ 22 th pin	270 ~330 Ω

Duct	Status
Air Flow	Windy
Air Temperature	Cold

Poor cooling in Fresh food section

1
Check the sensor resistance.



CON7 15 th pin ~ 16 th pin	Resistance [Ω]
23°F / -5°C	38k
32°F / 0°C	30k
41°F / 5°C	24k
50°F / 10°C	19.5k
59°F / 15°C	16k

2 Reset the unit and Input Test1 Mode.
(Push the button 1 time)



3
Open the fresh food door and Check the air flow. Windy?



No
Check the F Fan Motor
Check the damper
Go to 5

Yes

4
Check the air temperature.
Is it cold?

No
Check the Compressor and sealed system

Yes

Go to 9

5
Check the Damper Resistance
Is it correct compared with table?

No
Change Damper

CON8



CON8	Resistance [Ω]
19 rd pin ~ 21 th pin	270 ~330 Ω
20 rd pin ~ 22 th pin	270 ~330 Ω

Yes

6
Check the Fan motor.
Rotate fan using hand.
It feel sticky?

Yes
Change the Fan motor

Fan Motor

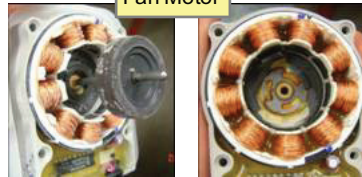

No

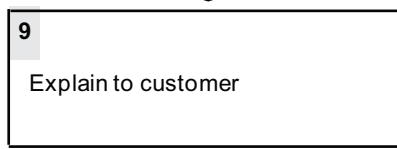
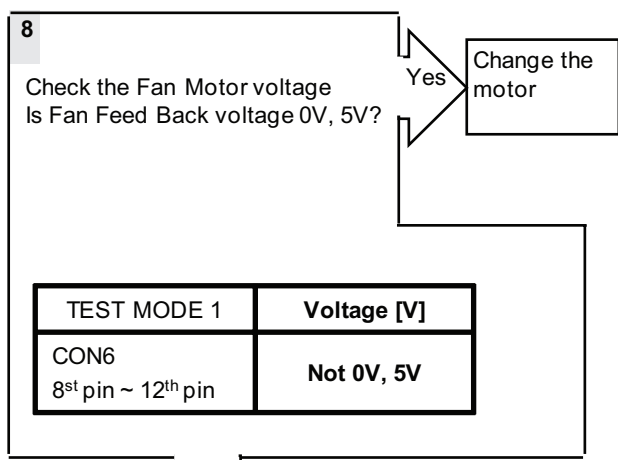
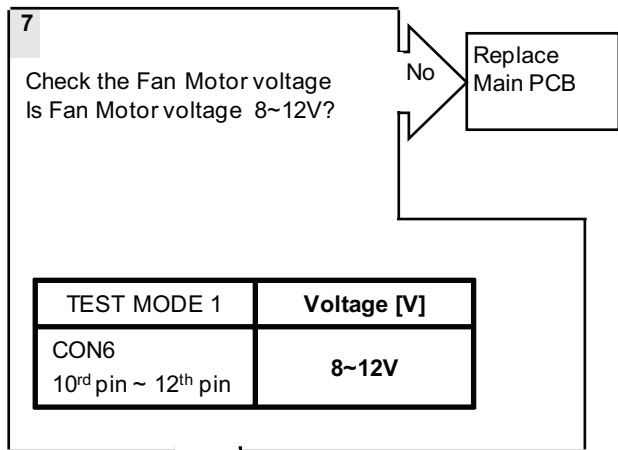

8-16. Poor cooling in Freezer compartment

Symptom	Check Point
1. Poor cooling in Freezer compartment	1. Check the sensor resistance 2. Check the air flow 3. Check the air Temperature 4. Check the Fan motor sticky 4. Check the Fan motor voltage

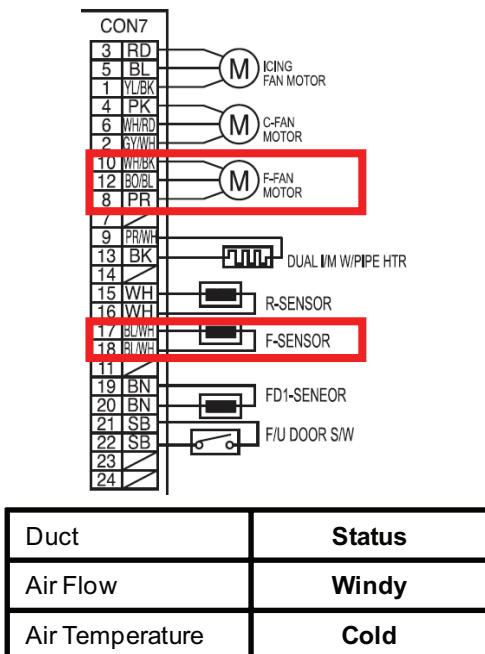
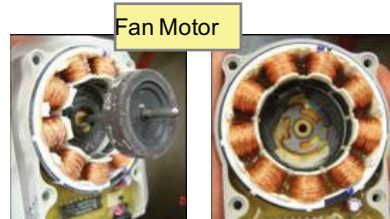
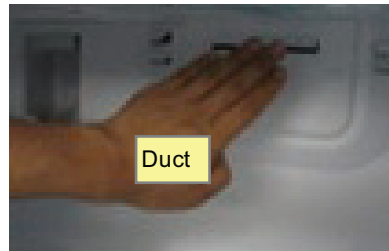
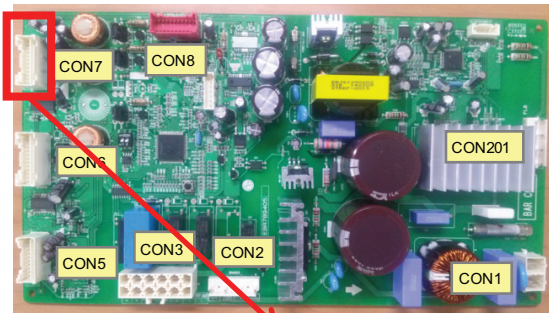

CON7 17 th pin ~ 18 th pin	Resistance [Ω]
-22°F / -30°C	40k
-13°F / -25°C	30k
-4°F / -20°C	23k
-13°F / -25°C	17k
14°F / -10°C	13k
23°F / -5°C	10k
32°F / 0°C	8k

TEST MODE 1	Voltage [V]
CON7 10 th pin ~ 12 th pin	8~12V
CON7 8 th pin ~ 12 th pin	Not 0V, 5V

Poor cooling in Freezer compartment

1
Check the sensor resistance.

CON7 17 th pin ~ 18 th pin	Resistance [Ω]
-22°F / -30°C	40k
-13°F / -25°C	30k
-4°F / -20°C	23k
-13°F / -25°C	17k
14°F / -10°C	13k
23°F / -5°C	10k
32°F / 0°C	8k

2 Reset the unit and Input Test1 Mode.
(Push the button 1 time)

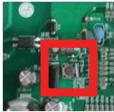

3
Open the fresh food door and Check the air flow. Windy?



No
Check the F Fan Motor
Go to 5

Yes

4
Check the air temperature.
Is it cold?

No
Check the Compressor and sealed system

Yes

5
Check the Fan motor.
Rotate fan using hand.
It feel sticky?

Yes
Change the Fan motor

Fan Motor

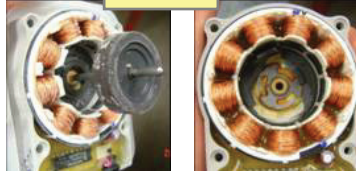

No

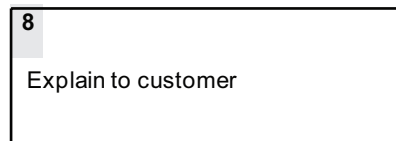
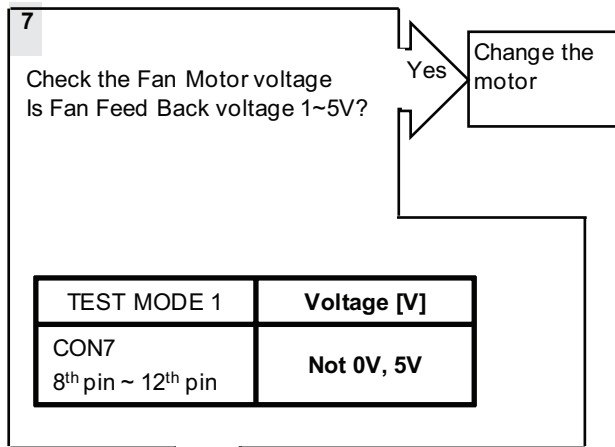
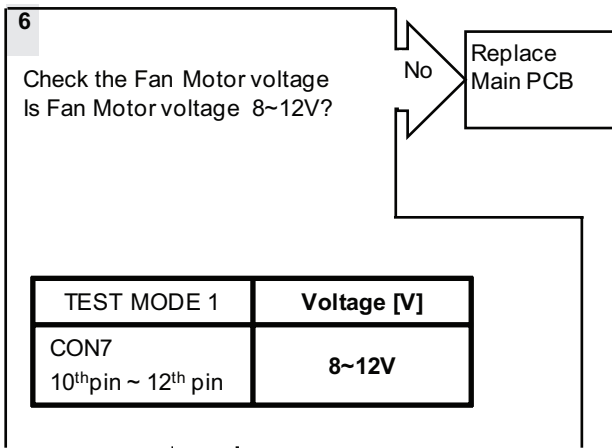

9. Reference

9-1 TEST MODE and Removing TPA

1. How to make TEST MODE

If you push the test button on the Main PCB, the refrigerator will be enter the TEST MODE.



Main PCB

* 1 time : Comp / Damper / All FAN on
(All things displayed)

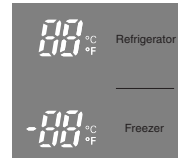

* 2 times : Damper closed
(22 22 displayed)



* 3 times : Forced defrost mode
(33 33 displayed)

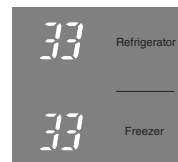

2. How to remove Terminal Position Assurance (TPA)

<AC TPA>

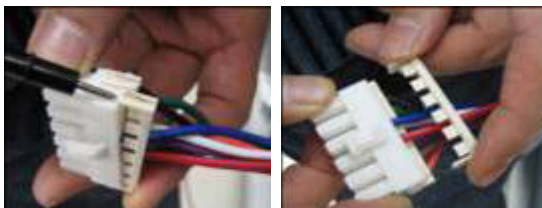

<DC TPA>



※ After measure the values, you should put in the TPA again.

9-2 TEMPERATRUE CHART - FREEZER AND ICING SENSOR

TEMP	RESISTANCE	VOLTAGE
-39°F (-40°C)	73.29 kΩ	4.09 V
-30°F (-35°C)	53.63 kΩ	3.84 V
-30°F (-21°C)	39.66 kΩ	3.55 V
-13°F (-25°C)	29.62 kΩ	3.23 V
-4°F (-20°C)	22.33 kΩ	2.89 V
5°F (-15°C)	16.99 kΩ	2.56 V
14°F (-10°C)	13.05 kΩ	2.23 V
23°F (-5°C)	10.10 kΩ	1.92 V
32°F (0°C)	7.88 kΩ	1.63 V
41°F (+5°C)	6.19 kΩ	1.38 V
50°F (+10°C)	4.91 kΩ	1.16 V
59°F (+15°C)	3.91 kΩ	0.97 V
68°F (+20°C)	3.14 kΩ	0.81 V
77°F (+25°C)	2.54 kΩ	0.67 V
86°F (+30°C)	2.07 kΩ	0.56 V
95°F (+35°C)	1.69 kΩ	0.47 V
104°F (+40°C)	1.39 kΩ	0.39 V

9-3 TEMPERATRUE CHART - REFRIGERATOR AND DEFROST SENSOR

TEMP	RESISTANCE	VOLTAGE
-39°F (-40°C)	225.1 kΩ	4.48 V
-30°F (-35°C)	169.8 kΩ	4.33 V
-30°F (-21°C)	129.3 kΩ	4.16 V
-13°F (-25°C)	99.30 kΩ	3.95 V
-4°F (-20°C)	76.96 kΩ	3.734 V
5°F (-15°C)	60.13 kΩ	3.487 V
14°F (-10°C)	47.34 kΩ	3.22 V
23°F (-5°C)	37.55 kΩ	2.95 V
32°F (0°C)	30 kΩ	2.67 V
41°F (+5°C)	24.13 kΩ	2.40 V
50°F (+10°C)	19.53 kΩ	2.14 V
59°F (+15°C)	15.91 kΩ	1.89 V
68°F (+20°C)	13.03 kΩ	1.64 V
77°F (+25°C)	10.74 kΩ	1.45 V
86°F (+30°C)	8.89 kΩ	1.27 V
95°F (+35°C)	7.40 kΩ	1.10 V
104°F (+40°C)	6.20 kΩ	0.96 V

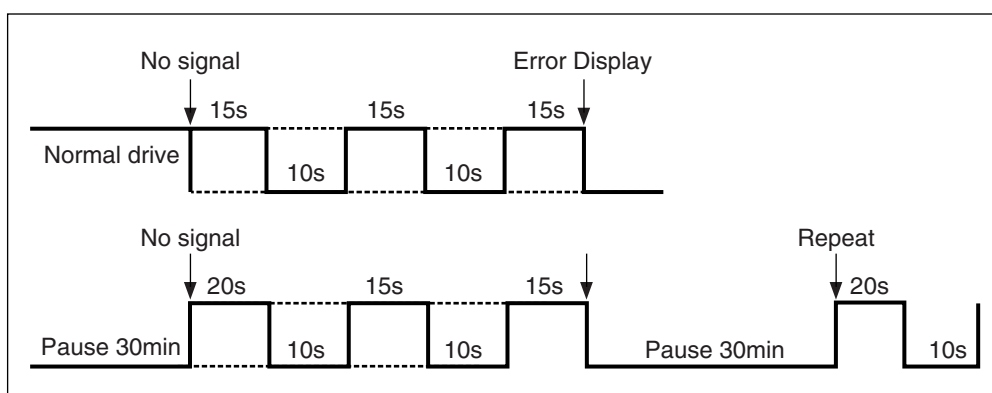

9-4 How to check the Fan-Error

After sending a signal to the fan, the MICOM checks the BLDC fan motor's lock status. If there is no feedback signal from the BLDC fan, the fan motor stops for 10 seconds and then is powered again for 15 seconds. To determine that there is a fan motor malfunction, this process is repeated 3 times. If the fan motor is determined to be defective, the error code will be shown in the display for 30 minutes. At this point, the process will be repeated until the fan motor operates normally. If normal operation is achieved, the error display is erased and the MICOM is reset automatically.



10. COMPONENT TESTING INFORMATION

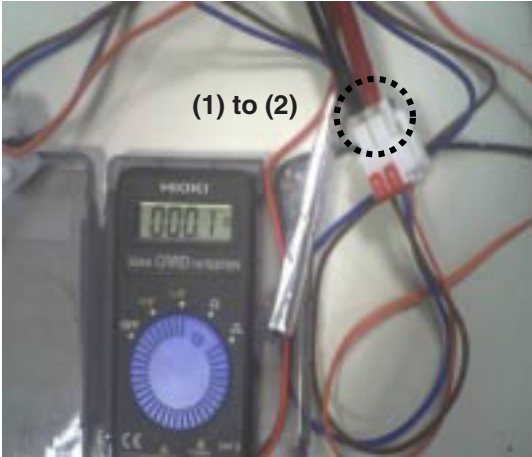

10-1 Defrost Controller Assembly

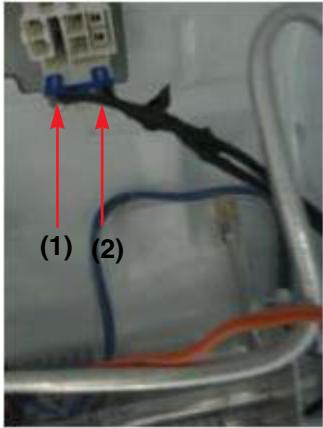

<p>Function</p>	<p>The controller assembly is made up of two different kinds of parts. The fuse and the sensor. To determine if these parts are defective, check for resistance. The fuse will cut power to the defrost heater at very high temperatures.</p>													
<p>How to Measure (Fuse-M)</p>		<p>Set a ohmmeter to the 2 housing pin. Measure the 2 pin connected to Fuse-M. If the ohmmeter indicate below 0.1ohm fuse-m is a good condition, But if infinite the part is bad.</p>												
<p>How to Measure (Sensor)</p>		<p>Set a ohmmeter to The 2housing pin. Measure the 2 pin connected to Sensor. If the ohmmeter indicate 11 kΩ (at room temperature) Sensor is good. When check the ohm at other temperatures Check the sensor manual.</p>												
<p>Standard</p>	<table border="1" style="margin-left: auto; margin-right: auto;"> <thead> <tr> <th colspan="2">Fuse-M (at all temperature)</th> </tr> <tr> <th>Test Point</th> <th>Ressult</th> </tr> </thead> <tbody> <tr> <td>(1) to (2)</td> <td>0 ~ 0.1 Ω</td> </tr> </tbody> </table>	Fuse-M (at all temperature)		Test Point	Ressult	(1) to (2)	0 ~ 0.1 Ω	<table border="1" style="margin-left: auto; margin-right: auto;"> <thead> <tr> <th colspan="2">Sensor (at room temperature)</th> </tr> <tr> <th>Test Point</th> <th>Ressult</th> </tr> </thead> <tbody> <tr> <td>(1) to (2)</td> <td>11 Ω</td> </tr> </tbody> </table>	Sensor (at room temperature)		Test Point	Ressult	(1) to (2)	11 Ω
Fuse-M (at all temperature)														
Test Point	Ressult													
(1) to (2)	0 ~ 0.1 Ω													
Sensor (at room temperature)														
Test Point	Ressult													
(1) to (2)	11 Ω													

10-2 Sheath Heater (Freezer Room)

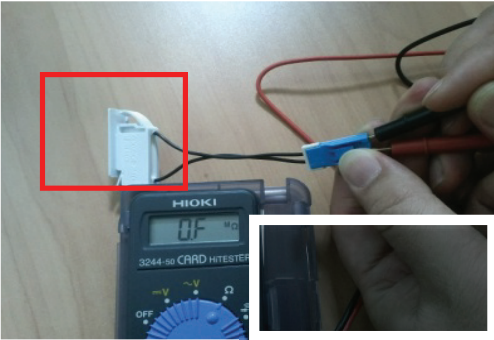
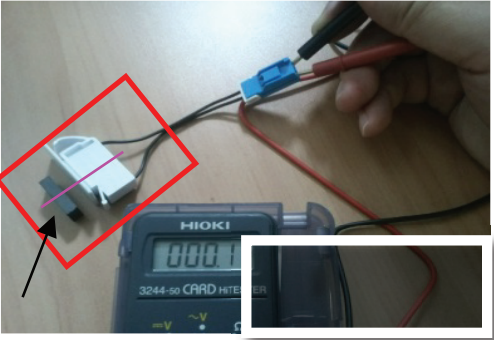
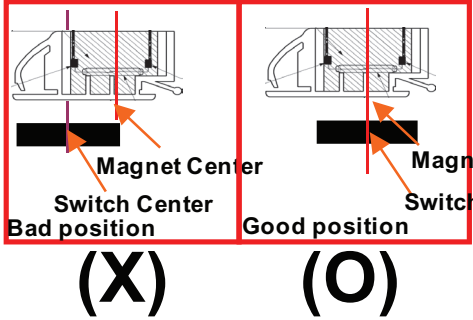

<p>Function</p>	<p>Sheath heater is the part for defrost. All heating wire is connected to only one line. So we can decide part is defective or not when we check the resistance.</p>				
<p>How to Measure</p>	<div style="display: flex; justify-content: space-around; align-items: center;">   </div> <p>Set a ohmmeter connect to The housing pins. Measure the pins connected to Sheath Heater. If the ohmmeter indicates $(V^{\circ}V)/Watt=R$ is on a good condition, ex) watt=350W, voltage=115V $R=(115^{\circ}115)/350=38 \Omega$ Infinitive value implies sheath heater is disconnected.</p>				
<p>Standard</p>	<p style="text-align: center;">Sheath heater (at all temperature)</p> <table border="1" style="margin-left: auto; margin-right: auto;"> <thead> <tr> <th>Test Point</th> <th>Ressult</th> </tr> </thead> <tbody> <tr> <td>(1) to (2)</td> <td>40~48 Ω</td> </tr> </tbody> </table>	Test Point	Ressult	(1) to (2)	40~48 Ω
Test Point	Ressult				
(1) to (2)	40~48 Ω				

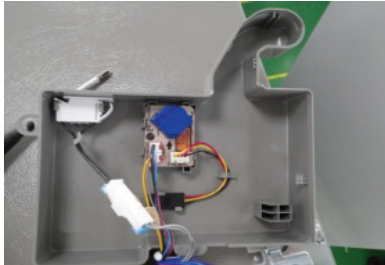
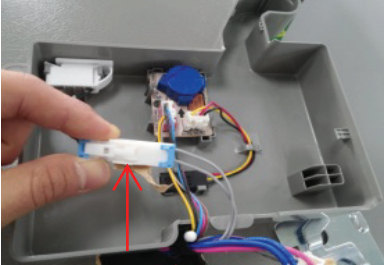
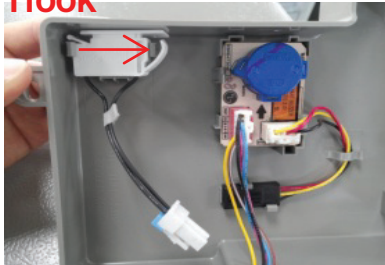
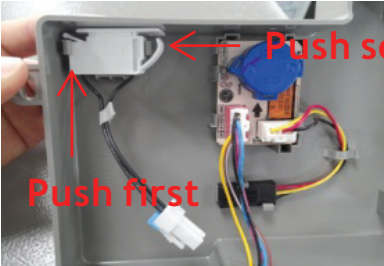
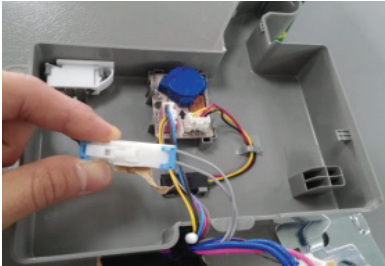
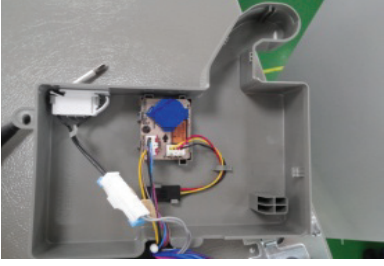





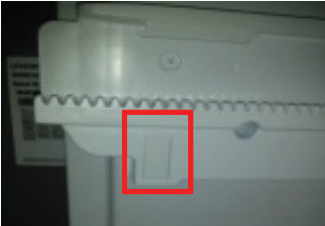

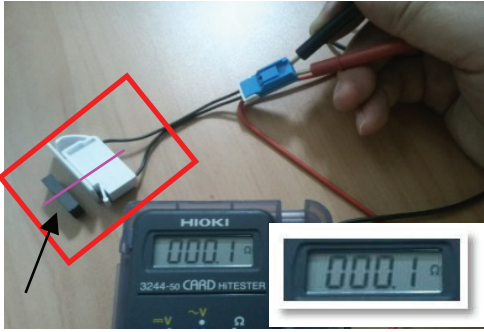
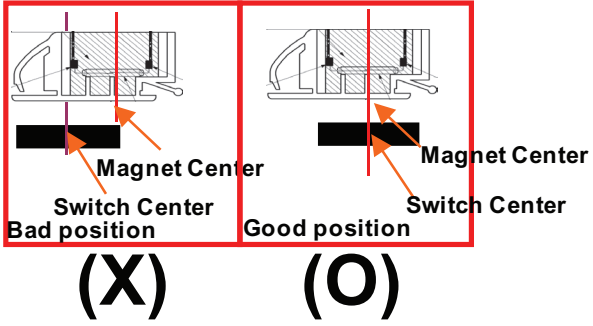
10-3 Door Switch
 10-3-1 Door Switch,R

No.	Checking Flow	Result & SVC Action																		
1	<p>▶ Check Reed Switch</p> 	<p>The Switch senses if the door is open or close. .When the door open, lamp On .When the door Close, lamp Off</p> <p>※ close Door and check the lamp Through the gap</p>																		
2	<p>▶ Check Voltage between pin 13 and 14</p>  <p>CON5</p>	<table border="1"> <thead> <tr> <th>Status</th> <th>Result</th> <th>SVC Action</th> </tr> </thead> <tbody> <tr> <td>In case of Door Close</td> <td>1V ↑</td> <td>1.Check Reed S/W 2.Check Harness disconnection 3.If No.1,2 ok ,change PCB</td> </tr> <tr> <td>In case of Door Open</td> <td>0V</td> <td>1.Check Reed S/W 2.Check Harness disconnection 3.If No.1,2 ok ,change PCB</td> </tr> </tbody> </table>	Status	Result	SVC Action	In case of Door Close	1V ↑	1.Check Reed S/W 2.Check Harness disconnection 3.If No.1,2 ok ,change PCB	In case of Door Open	0V	1.Check Reed S/W 2.Check Harness disconnection 3.If No.1,2 ok ,change PCB									
Status	Result	SVC Action																		
In case of Door Close	1V ↑	1.Check Reed S/W 2.Check Harness disconnection 3.If No.1,2 ok ,change PCB																		
In case of Door Open	0V	1.Check Reed S/W 2.Check Harness disconnection 3.If No.1,2 ok ,change PCB																		
3	<p>▶ Check the Reed S/W resistance</p> <p>-.No Magnet</p>  <p>-.Magnet Near the Switch</p> 	<p>-.Magnet must be center of Switch</p>  <p>-.Resistance & Service Action</p> <table border="1"> <thead> <tr> <th>Status</th> <th>Resistance</th> <th>Result</th> <th>SVC Action</th> </tr> </thead> <tbody> <tr> <td rowspan="2">No magnet near the Switch</td> <td>$\infty \Omega$</td> <td>O.K.</td> <td>Go to 2</td> </tr> <tr> <td>$10 \Omega \downarrow$</td> <td>N.G.</td> <td>Go to 4</td> </tr> <tr> <td rowspan="2">Magnet is near the Switch</td> <td>$1 \Omega \downarrow$</td> <td>O.K.</td> <td>Go to 2</td> </tr> <tr> <td>$10 \Omega \uparrow$</td> <td>N.G.</td> <td>Go to 4</td> </tr> </tbody> </table>	Status	Resistance	Result	SVC Action	No magnet near the Switch	$\infty \Omega$	O.K.	Go to 2	$10 \Omega \downarrow$	N.G.	Go to 4	Magnet is near the Switch	$1 \Omega \downarrow$	O.K.	Go to 2	$10 \Omega \uparrow$	N.G.	Go to 4
Status	Resistance	Result	SVC Action																	
No magnet near the Switch	$\infty \Omega$	O.K.	Go to 2																	
	$10 \Omega \downarrow$	N.G.	Go to 4																	
Magnet is near the Switch	$1 \Omega \downarrow$	O.K.	Go to 2																	
	$10 \Omega \uparrow$	N.G.	Go to 4																	

No.	Checking Flow	Result & SVC Action
4	<p>▶ Change Reed S/W -. Remove screw</p>	
		
	<p>-. Disassemble Housing</p>  <p style="text-align: center;">Push Hook</p>	<p style="text-align: center;">Push Hook</p> 
	<p>-. Check Resistance of Reed S/W. if it is NG, change it(Number3)</p>	
	<p>-. Assemble Reed S/W to hinge cover and Assemble Reed S/W Housing</p>	
	 <p style="text-align: center;">Push first</p> <p style="text-align: center;">Push second</p>	
<p>-. Assemble Screw to hinge cover</p>		
		

10-3-2 Door Switch,F

No.	Checking Flow	Result & SVC Action																		
1	<p>▶ Check the Freezer door switch</p> 	<p>The Switch senses if the door is open or close. .When the door open, lamp On .When the door Close, lamp Off</p> <p>※ close Door and check the lamp Through the gap</p>																		
2	<p>▶ Check Voltage between pin 21 and 22</p> 	<table border="1"> <thead> <tr> <th>Status</th> <th>Result</th> <th>SVC Action</th> </tr> </thead> <tbody> <tr> <td>In case of Door Close</td> <td>1V ↑</td> <td>1.Check Reed S/W 2.Check Harness disconnection 3.If No.1,2 ok ,change PCB</td> </tr> <tr> <td>In case of Door Open</td> <td>0V</td> <td>1.Check Reed S/W 2.Check Harness disconnection 3.If No.1,2 ok ,change PCB</td> </tr> </tbody> </table>	Status	Result	SVC Action	In case of Door Close	1V ↑	1.Check Reed S/W 2.Check Harness disconnection 3.If No.1,2 ok ,change PCB	In case of Door Open	0V	1.Check Reed S/W 2.Check Harness disconnection 3.If No.1,2 ok ,change PCB									
Status	Result	SVC Action																		
In case of Door Close	1V ↑	1.Check Reed S/W 2.Check Harness disconnection 3.If No.1,2 ok ,change PCB																		
In case of Door Open	0V	1.Check Reed S/W 2.Check Harness disconnection 3.If No.1,2 ok ,change PCB																		
3	<p>▶ Check the Reed S/W resistance</p> <p>-No Magnet</p>  <p>-Magnet Near the Switch</p> 	<p>-Magnet must be center of Switch</p>  <p>(X) (O)</p> <p>-Resistance & Service Action</p> <table border="1"> <thead> <tr> <th>Status</th> <th>Resistance</th> <th>Result</th> <th>SVC Action</th> </tr> </thead> <tbody> <tr> <td rowspan="2">No magnet near the Switch</td> <td>$\infty \Omega$</td> <td>O.K.</td> <td>Go to 2</td> </tr> <tr> <td>$10 \Omega \downarrow$</td> <td>N.G.</td> <td>Go to 4</td> </tr> <tr> <td rowspan="2">Magnet is near the Switch</td> <td>$1 \Omega \downarrow$</td> <td>O.K.</td> <td>Go to 2</td> </tr> <tr> <td>$10 \Omega \uparrow$</td> <td>N.G.</td> <td>Go to 4</td> </tr> </tbody> </table>	Status	Resistance	Result	SVC Action	No magnet near the Switch	$\infty \Omega$	O.K.	Go to 2	$10 \Omega \downarrow$	N.G.	Go to 4	Magnet is near the Switch	$1 \Omega \downarrow$	O.K.	Go to 2	$10 \Omega \uparrow$	N.G.	Go to 4
Status	Resistance	Result	SVC Action																	
No magnet near the Switch	$\infty \Omega$	O.K.	Go to 2																	
	$10 \Omega \downarrow$	N.G.	Go to 4																	
Magnet is near the Switch	$1 \Omega \downarrow$	O.K.	Go to 2																	
	$10 \Omega \uparrow$	N.G.	Go to 4																	

No.	Checking Flow	Result & SVC Action
4	<p>▶ Change Reed S/W -. Remove 3 screw and divide housing</p>	
		
	<p>-. Divide Reed S/W</p>  <p style="text-align: center; color: red;">Push</p>	
	<p>-.Push the part of hook and divide Reed S/W -.Check the Reed S/W resistance and if it is NG. Change it (Number 3)</p>	
	<p>-.Push the Reed S/W to direction of the arrow</p>	
	 <p style="text-align: center; color: red;">First push</p>	 <p style="text-align: center; color: red;">Second push</p>
<p>-. Assemble 3 Screw after Assemble Reed Switch housing</p>		
		

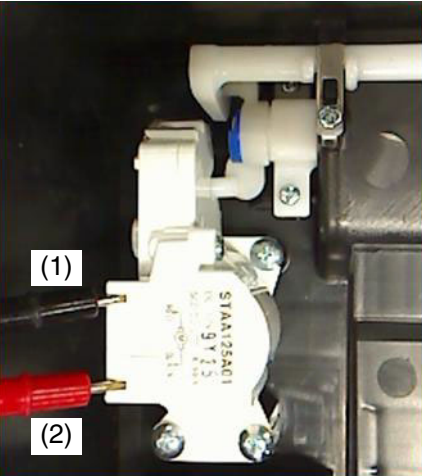

10-4 Dispenser DC Motor

Function	. Dispenser DC Motor : When customer push the dispenser button, Pull duct door and abstract from ice bank.						
How to Measure	<div style="text-align: center;">  <p>Dispenser DC Motor</p> </div>						
Standard	<table border="1" style="margin-left: auto; margin-right: auto;"> <thead> <tr> <th colspan="2" style="text-align: center;">Dispenser DC Motor</th> </tr> <tr> <th style="text-align: center;">Test Points</th> <th style="text-align: center;">Result</th> </tr> </thead> <tbody> <tr> <td style="text-align: center;">(1) to (2)</td> <td style="text-align: center;">9.9 ~ 12.1 Ω</td> </tr> </tbody> </table>	Dispenser DC Motor		Test Points	Result	(1) to (2)	9.9 ~ 12.1 Ω
Dispenser DC Motor							
Test Points	Result						
(1) to (2)	9.9 ~ 12.1 Ω						

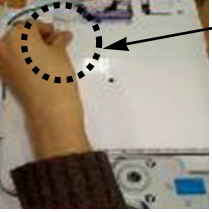
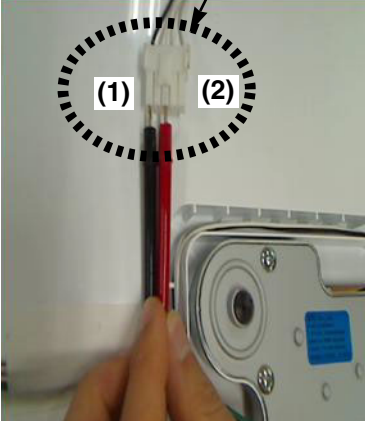
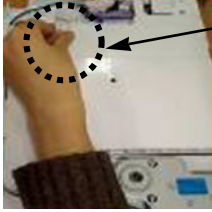
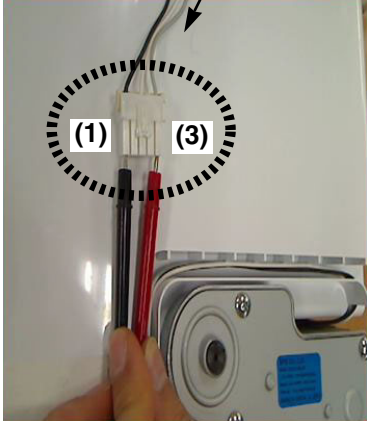
10-5 AC Motor ASSEMBLY

<p>Function</p>	<p>The motor in the door pushed the ice into the dispenser.</p>									
<p>How to Measure</p>	<p>< In-door Motor ></p>  <p>① Separate the housing.</p>  <p>② Measure the resistance between (1) and (2)</p>	<p>< In-door Motor ></p>  <p>① Separate the housing.</p>  <p>② Measure the resistance between (1) and (3)</p> <p>Check the resistance between connectors (In-door motor 1, 2) and (In-door motor 1, 3). It means check whether or not applying an Electric current. If there is resistance, it means the geared motor or solenoid is not inferiority</p>								
<p>Standard</p>	<p>Geared Motor (Crush mode)</p> <table border="1" data-bbox="418 1681 868 1776"> <thead> <tr> <th>Test Points</th> <th>Result</th> </tr> </thead> <tbody> <tr> <td>(1) to (2)</td> <td>31.1~42.09 Ω</td> </tr> </tbody> </table>	Test Points	Result	(1) to (2)	31.1~42.09 Ω	<p>Geared Motor (Cube mode)</p> <table border="1" data-bbox="941 1681 1393 1776"> <thead> <tr> <th>Test Points</th> <th>Result</th> </tr> </thead> <tbody> <tr> <td>(1) to (3)</td> <td>31.1~42.09 Ω</td> </tr> </tbody> </table>	Test Points	Result	(1) to (3)	31.1~42.09 Ω
Test Points	Result									
(1) to (2)	31.1~42.09 Ω									
Test Points	Result									
(1) to (3)	31.1~42.09 Ω									

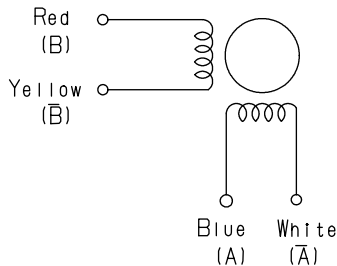
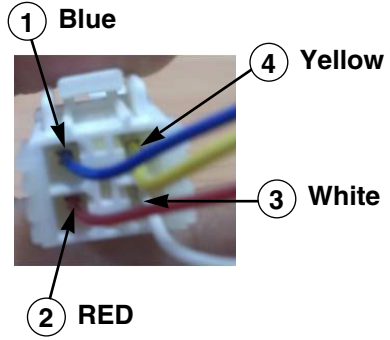
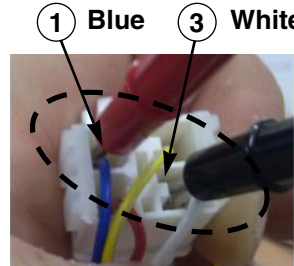
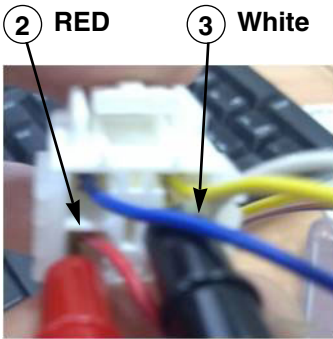

10-6 Damper

<p>Function</p>	<p>The damper supplies cold air from the freezer to the chill room using the damper plate. The chill room is colder when the damper plate is open. When the damper is closed the chill rooms temperature will rise.</p>																													
<p>How to Measure</p>	<div style="border: 1px dashed black; padding: 10px; margin-bottom: 10px;"> <p>Table(1): 결선도(Wiring)</p>  <p>Table(2): 2-2상 여자순서(CW Rotation)</p> <table border="1" style="width: 100%; border-collapse: collapse; text-align: center;"> <thead> <tr> <th rowspan="2">Housing No. & L/Wire Color</th> <th colspan="4">Step</th> </tr> <tr> <th>1</th> <th>2</th> <th>3</th> <th>4</th> </tr> </thead> <tbody> <tr> <td>1- Blue (A)</td> <td>+</td> <td>-</td> <td>-</td> <td>+</td> </tr> <tr> <td>2- Red (B)</td> <td>+</td> <td>+</td> <td>-</td> <td>-</td> </tr> <tr> <td>3- White(A)</td> <td>-</td> <td>+</td> <td>+</td> <td>-</td> </tr> <tr> <td>4- Yellow(B)</td> <td>-</td> <td>-</td> <td>+</td> <td>+</td> </tr> </tbody> </table> </div> <p style="text-align: center;">< Damper Circuit ></p> <div style="display: flex; justify-content: space-around;"> <div style="text-align: center;">  </div> <div style="text-align: center;">  </div> </div> <div style="display: flex; justify-content: space-around; margin-top: 20px;"> <div style="text-align: center;">  </div> <div style="text-align: center;">  </div> </div> <div style="text-align: center; margin-top: 10px;">  </div> <p style="text-align: center; margin-top: 20px;">Check to see if there is electrical current, if there is resistance the damper is good.</p>	Housing No. & L/Wire Color	Step				1	2	3	4	1- Blue (A)	+	-	-	+	2- Red (B)	+	+	-	-	3- White(A)	-	+	+	-	4- Yellow(B)	-	-	+	+
Housing No. & L/Wire Color	Step																													
	1	2	3	4																										
1- Blue (A)	+	-	-	+																										
2- Red (B)	+	+	-	-																										
3- White(A)	-	+	+	-																										
4- Yellow(B)	-	-	+	+																										
<p>Standard</p>	<p style="text-align: center;">Damper</p> <table border="1" style="width: 100%; border-collapse: collapse; text-align: center;"> <thead> <tr> <th>Test Points</th> <th>Result</th> <th>Test Points</th> <th>Result</th> </tr> </thead> <tbody> <tr> <td>Red and Yellow</td> <td>270 ~ 330 Ω</td> <td>Blue and White</td> <td>270 ~ 330 Ω</td> </tr> </tbody> </table>	Test Points	Result	Test Points	Result	Red and Yellow	270 ~ 330 Ω	Blue and White	270 ~ 330 Ω																					
Test Points	Result	Test Points	Result																											
Red and Yellow	270 ~ 330 Ω	Blue and White	270 ~ 330 Ω																											

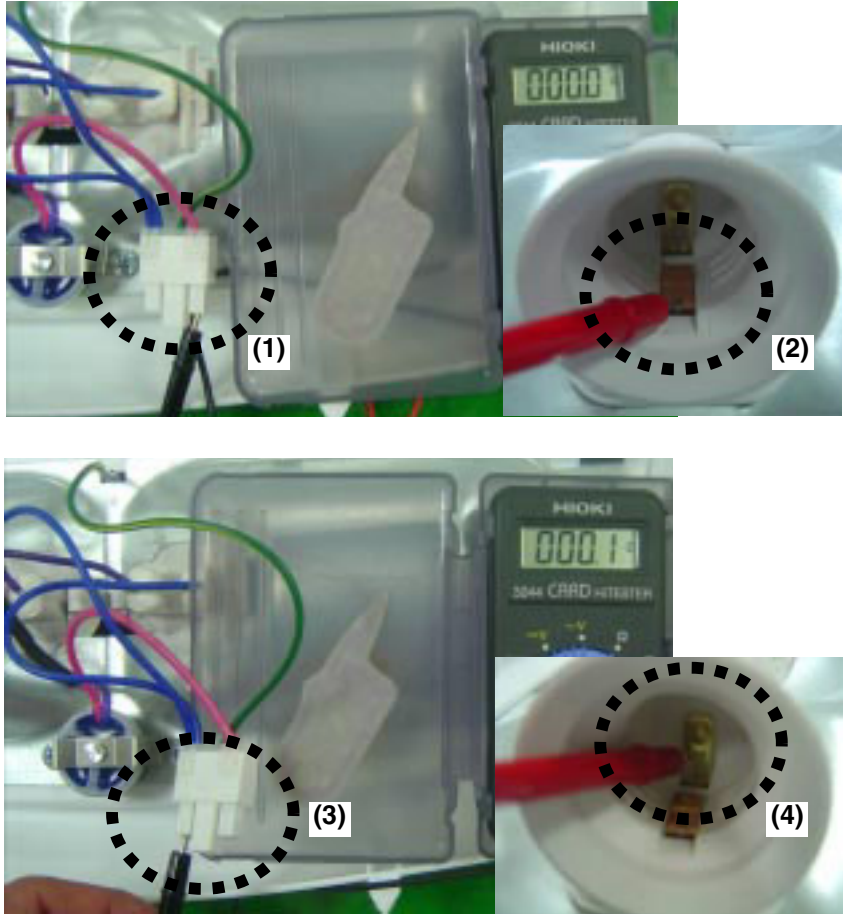
10-7 Lamp Socket

<p>Function</p>	<p>The lamp socket connect cover lamp assembly to lamp. The lamp socket fix lamp and unite lamp and cover lamp assembly. The lamp socket supply electric source to lamp also.</p>				
<p>How to Measure</p>	<div style="text-align: center;">  </div> <p>Check the resistance between connector of housing and connector of lamp socket. It means check whether or not applying an electric current. If there is resistance it means the lamp socket is good.</p>				
<p>Standard</p>	<table border="1" style="margin-left: auto; margin-right: auto;"> <thead> <tr> <th style="text-align: center;">Test Points</th> <th style="text-align: center;">Result</th> </tr> </thead> <tbody> <tr> <td style="text-align: center;">(1) to (2) and (3) to (4)</td> <td style="text-align: center;">$0\ \Omega$</td> </tr> </tbody> </table>	Test Points	Result	(1) to (2) and (3) to (4)	$0\ \Omega$
Test Points	Result				
(1) to (2) and (3) to (4)	$0\ \Omega$				

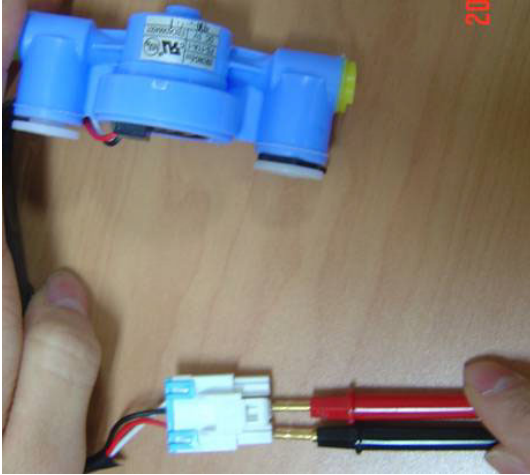
10-8 Flow Sensor

Function	Flow Sensor (in machine room) Count the water quantity from city water to water filter in refrigerator					
How to Measure	 <p style="text-align: center;">Flow Sensor (in machine room)</p>					
Standard	<table border="1" style="margin-left: auto; margin-right: auto;"> <thead> <tr> <th>Test Points</th> <th>Result</th> </tr> </thead> <tbody> <tr> <td>Red wire to Black wire</td> <td>4 ~ 30 kΩ</td> </tr> </tbody> </table>		Test Points	Result	Red wire to Black wire	4 ~ 30 kΩ
Test Points	Result					
Red wire to Black wire	4 ~ 30 kΩ					

11. Compressor Troubleshooting

PCB Check (Simplify)

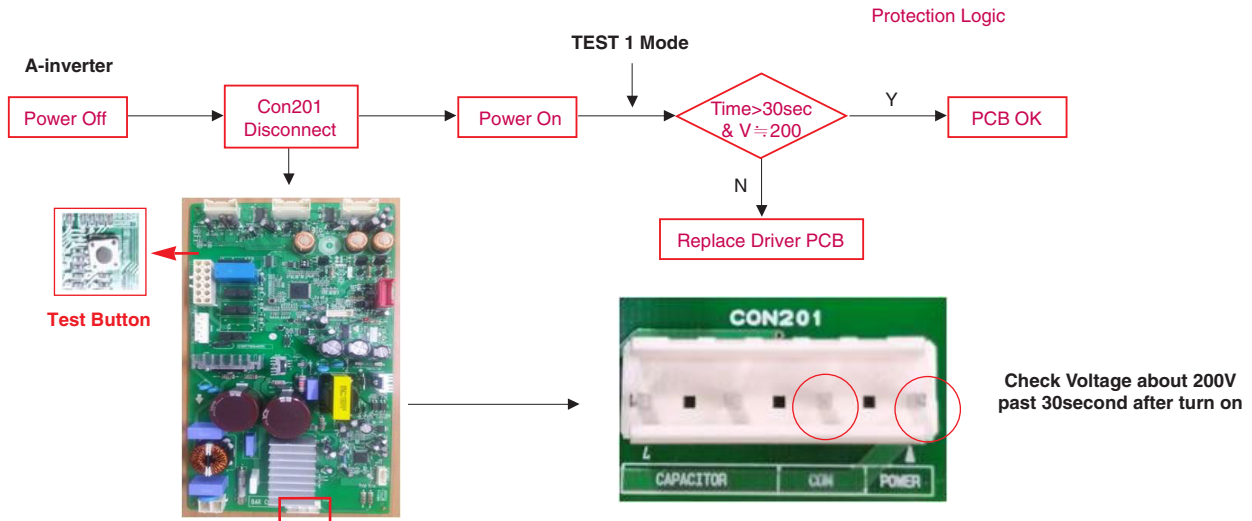

Test Mode

	Ref.	Comp	Display & sound	Refer
		FLB075(A-Inverter)		
TEST1	Forced Starting	TDC (Full Stroke)	Display ON, Buzz 1 time	

Troubleshooting

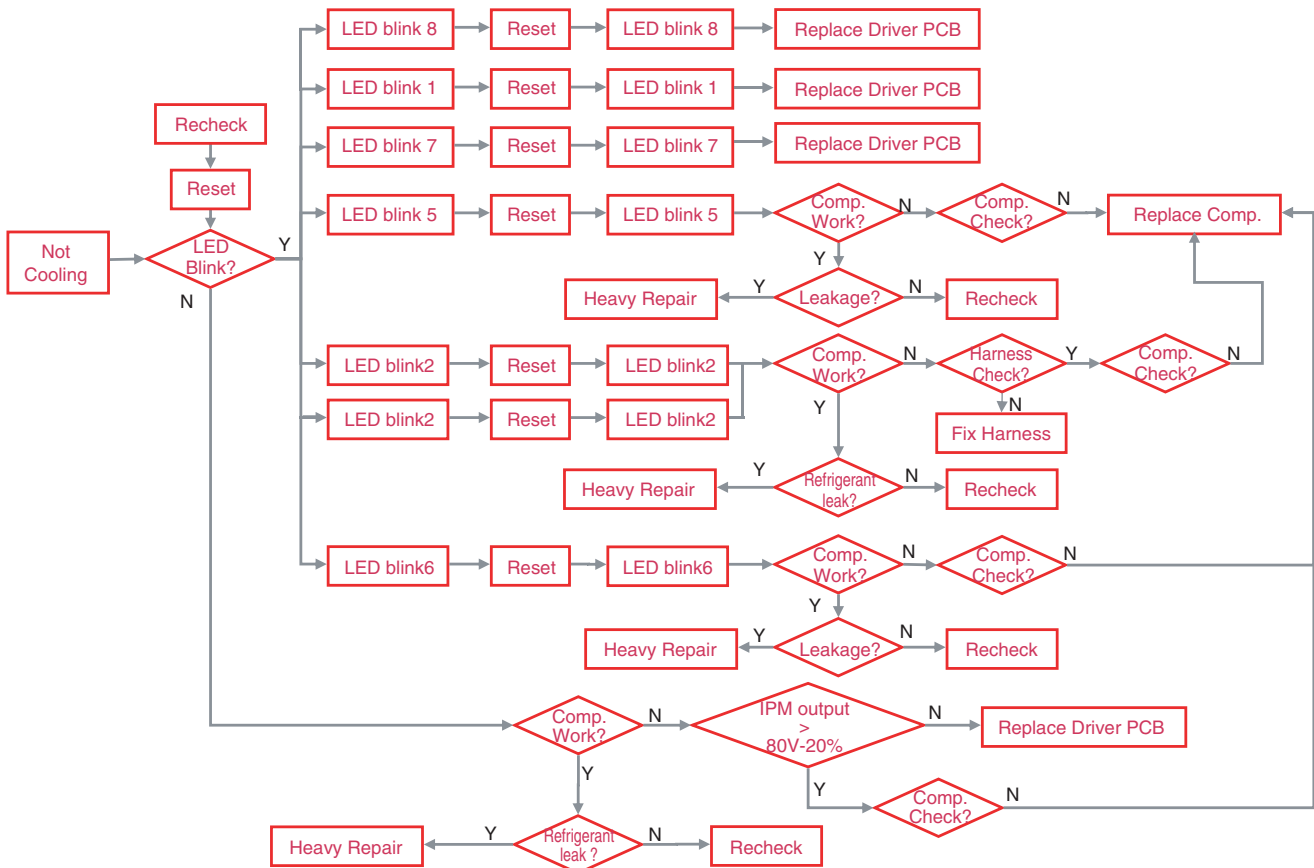

11-1 Check A

- There is PC Board located in the PCB case.
The control driver is PC board for the compressor.
- This step shows the source voltage of the driver PC board.

Step1. Open PCB Cover



Step2. Check Driver PCB

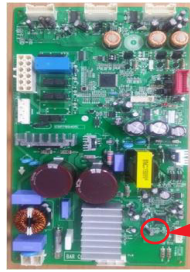

LED Lamp

- * Driver PCB located in back plate cover behind the refrigerator.

IPM Output check

- Measure the voltage between the POWER and COMM pins of the connector as shown below.

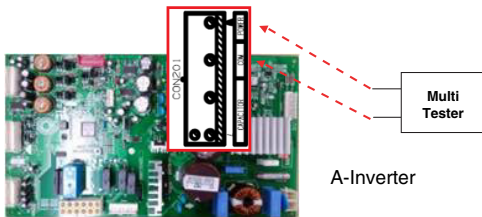

Check to make sure compressor is receiving voltage from IPM

- In order to determine whether the compressor is operating normally, check the output voltage during the refrigeration cycle.
- After initial power-up, when the compressor begins to operate, wait 10 minutes before checking.
- The compressor is operating normally if the voltage is greater than 80V.

11-2 Check B

B1. LED blinks once, then repeats (FCT0 Fault)

Protection Logic



Blink OFF Blink OFF

- Purpose: Detecting motor current and voltage error
- Check voltage at **point A** (Motor Voltage), **point B** (Motor Current) and **Point C** (Capacitor Voltage) when **compressor is off**.
- Spec: **Points A, B, & C $2.5V \pm 0.3V$**

⊙ GND
○ Voltage

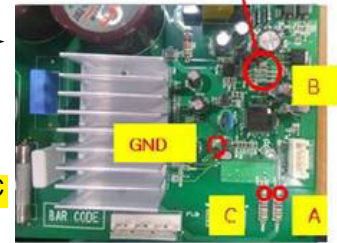
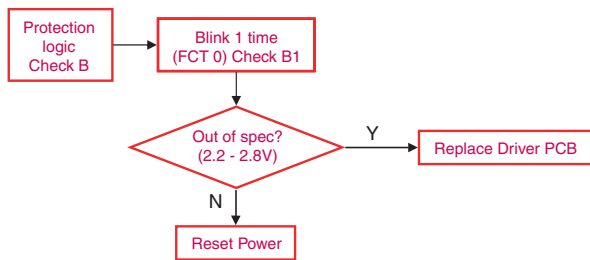

※ Caution : Devices should not be short-circuited during check C

B2. LED blinks two times, then repeats (Stroke Trip)

Protection Logic



Blink Blink OFF Blink Blink OFF

- Purpose: Prevent abnormally long piston strokes.
- Case 1. If compressor doesn't work and LED blinks - Cause: Possibly harness from compressor to PCB might be defective.
- Case 2. If compressor works intermittently and LED blinks - Cause: Condenser Fan or Freezer Fan is not running. Sealed system problem such as moisture restriction, restriction at capillary tube or refrigerant leak.
- Logic: Compressor is forced to off and then tries to restart after 1 minute.

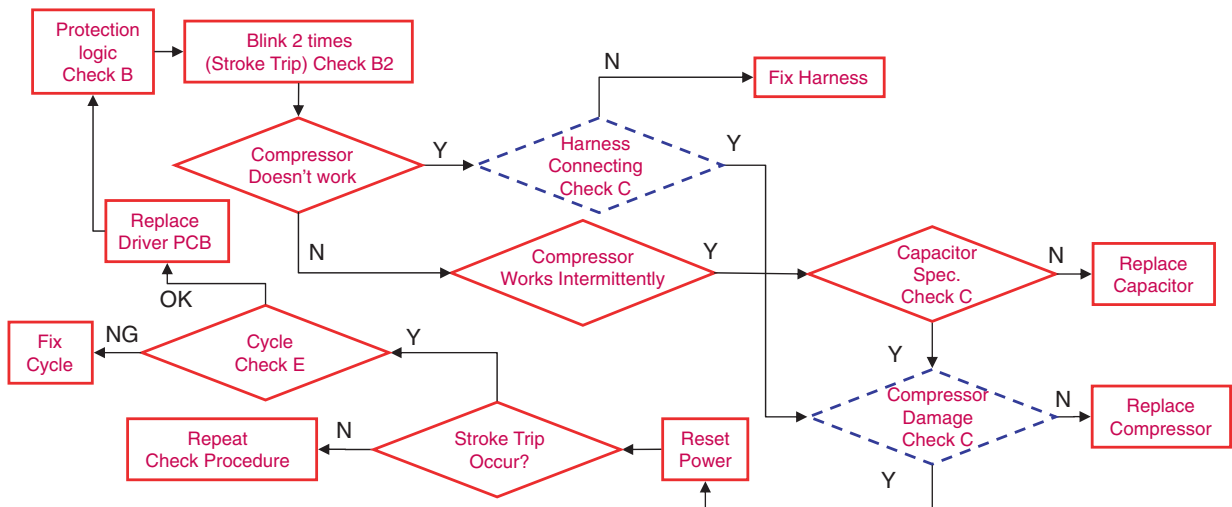

B3. LED blinks three times, then repeats (Stroke Trip)

Protection Logic



Blink Blink Blink OFF Blink Blink Blink OFF

- Purpose: Prevent over voltage and current detecting connecting error.
- Cause: -. Connecting error of PCB and Comp, Capacitor Harness -. Comp insulation damage
- Logic: Compressor is forced off and tries to restart within 40 seconds.

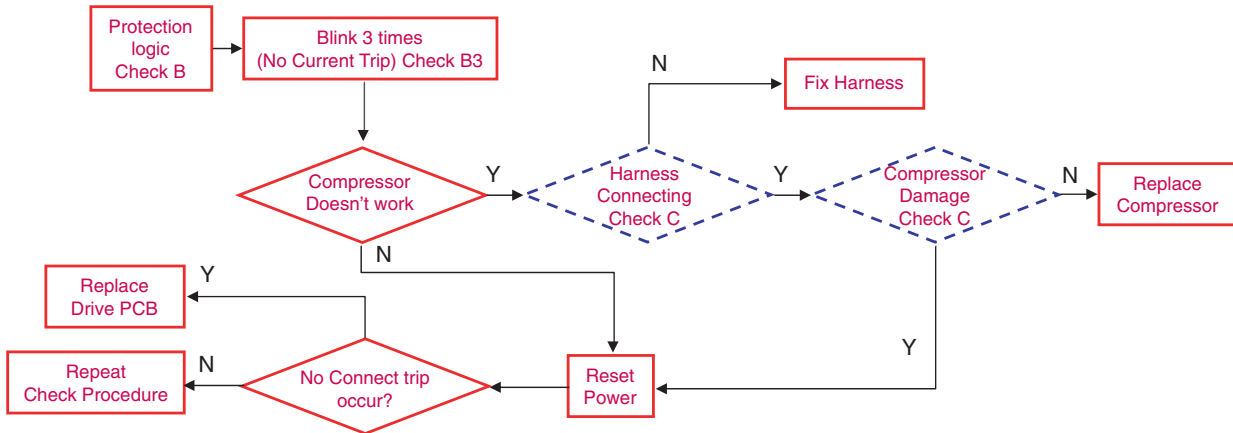

B4. LED blinks five times, then repeats (Locked Piston: A & E Inverters)

Protection Logic



Blink Blink Blink Blink Blink OFF

- Purpose: To detect locked piston
- Cause: Lack of oil to the cylinder, cylinder or piston damaged and or restricted discharge. A Locked Piston can also be caused by foreign materials inside the compressor.
- Logic: Compressor is forced off and tries to restart within 2.5 minutes.

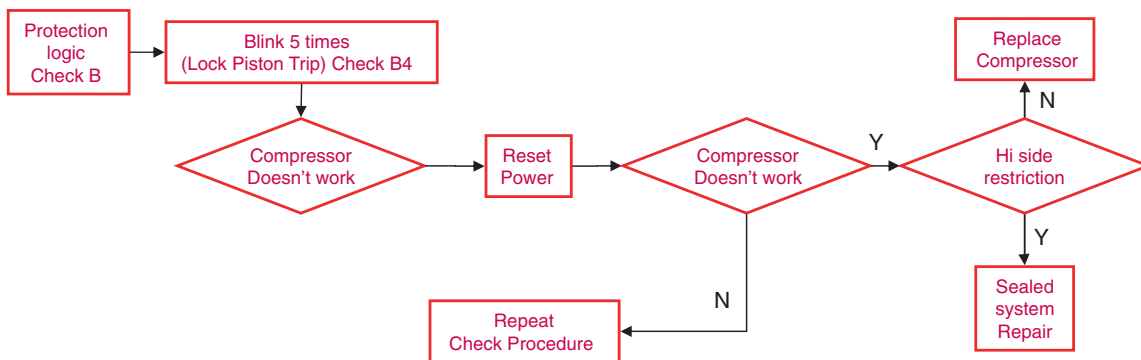

B5. LED blinks six times, then repeats (Current Trip: A & E-Inverters)

Protection Logic



Blink Blink Blink Blink Blink Blink OFF

- Purpose: Prevent over-current (overload protect)
- Cause: Ambient temperature is high (over 43°C) and/or refrigerator's condenser air movement is restricted.
- Condenser Fan is stopped, restricted discharge line, compressor is damaged, or IPM device is defective.
- Logic: Compressor is forced off and tries to restart after 6 minutes.

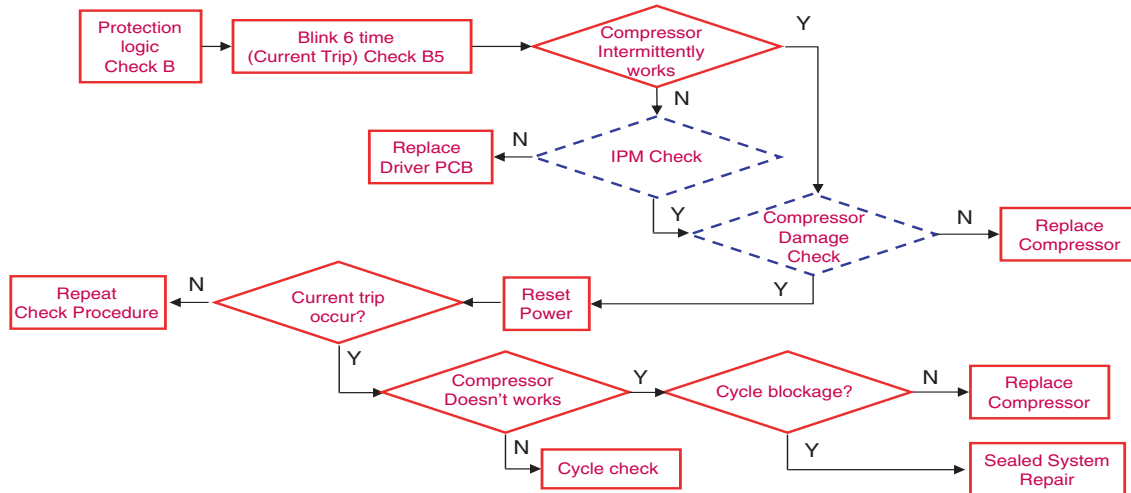

B6. LED blinks seven times, then repeats

Protection Logic



Blink Blink Blink Blink Blink Blink Blink OFF

- Purpose: Prevent high current due to IPM Short
- Cause: Damaged IPM (Dead Short)
- Test for a dead short at **Point A** with a VOM.
- Logic: Compressor is forced off and tries to restart in 20 seconds.

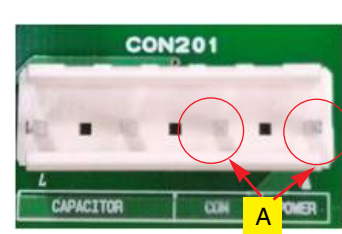
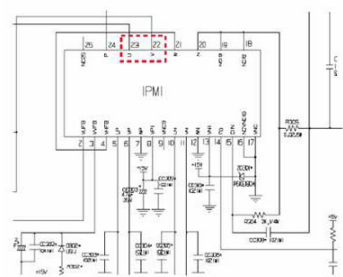
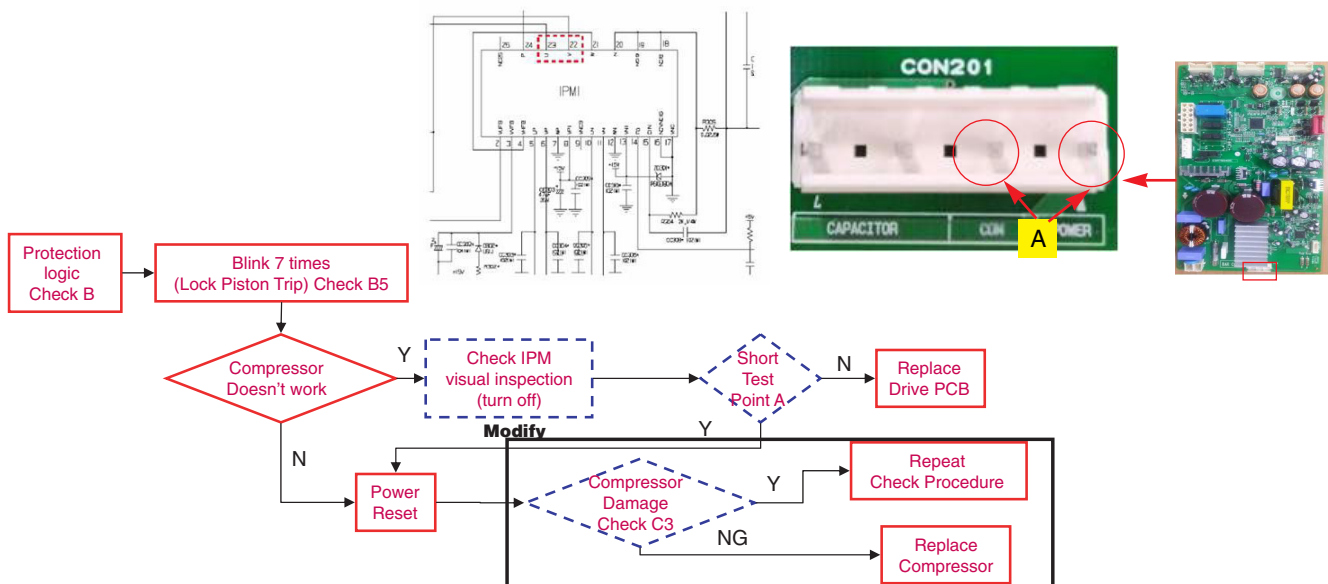

B7. LED Blink eight times, then repeats (Communication Error)

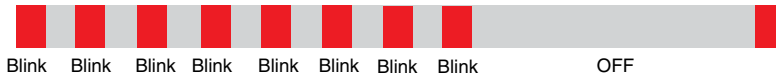

- Purpose: To detect Set control Micom and communication error
- Cause: -. Communication Error
- Logic: LED blink (Compressor runs reference value before occuring communicationError)

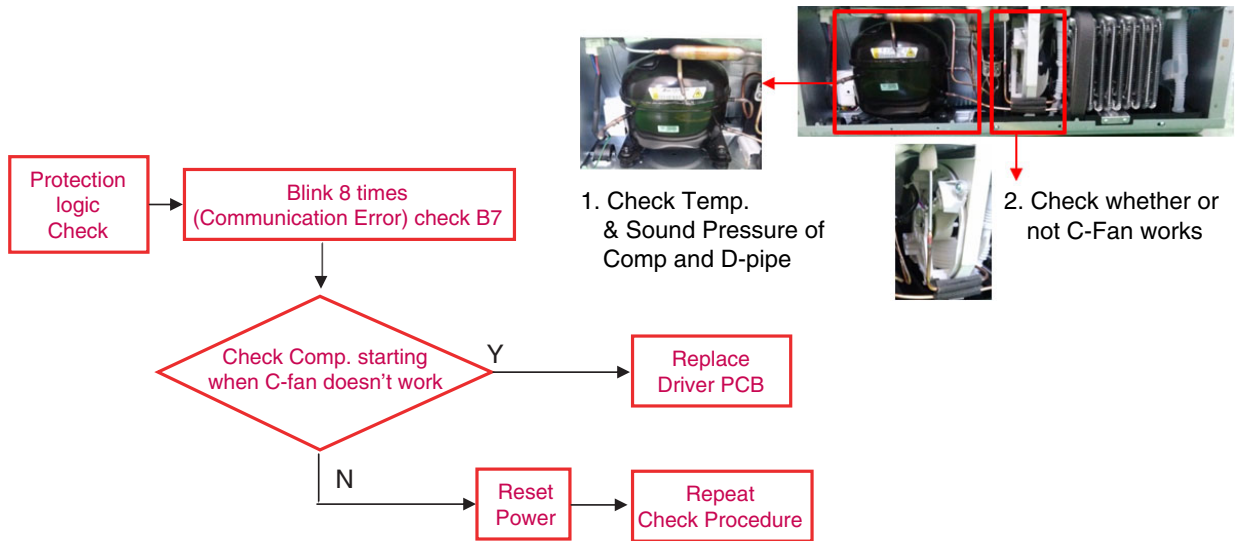

11-3 Check C

- C1. Harness Connection Check
- C2. Capacitor Specifications
- C3. Compressor Check

Check Process

- Step 1. Power off. Step 2. Check capacitor spec. (table1). Step3. Check resistance of point A
- Step 4. Check wire harness (INF ohm). Step 5. Check resistance at point B. Step 6. Point D.

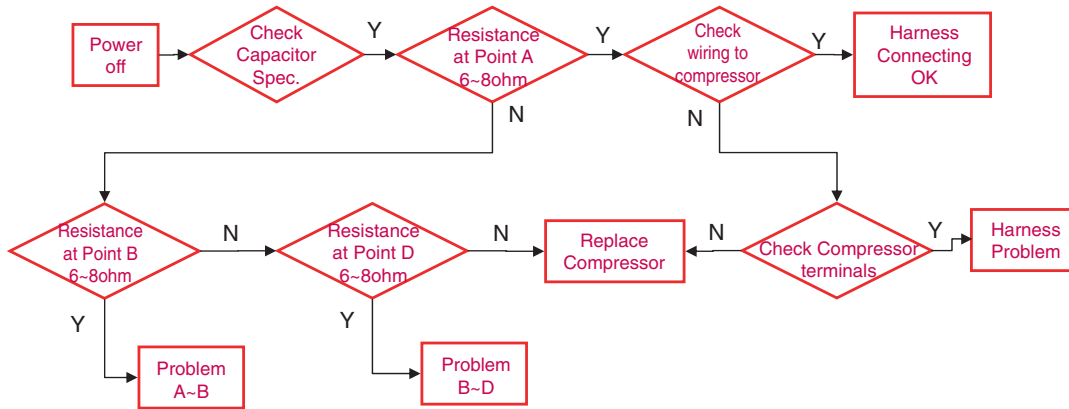

Caution : Turn off power during check C

- Measure the resistance at each point except point C
- Dead short check: measure the resistance between power line in compressor and earth ground in refrigerator (Inf. Ohm)

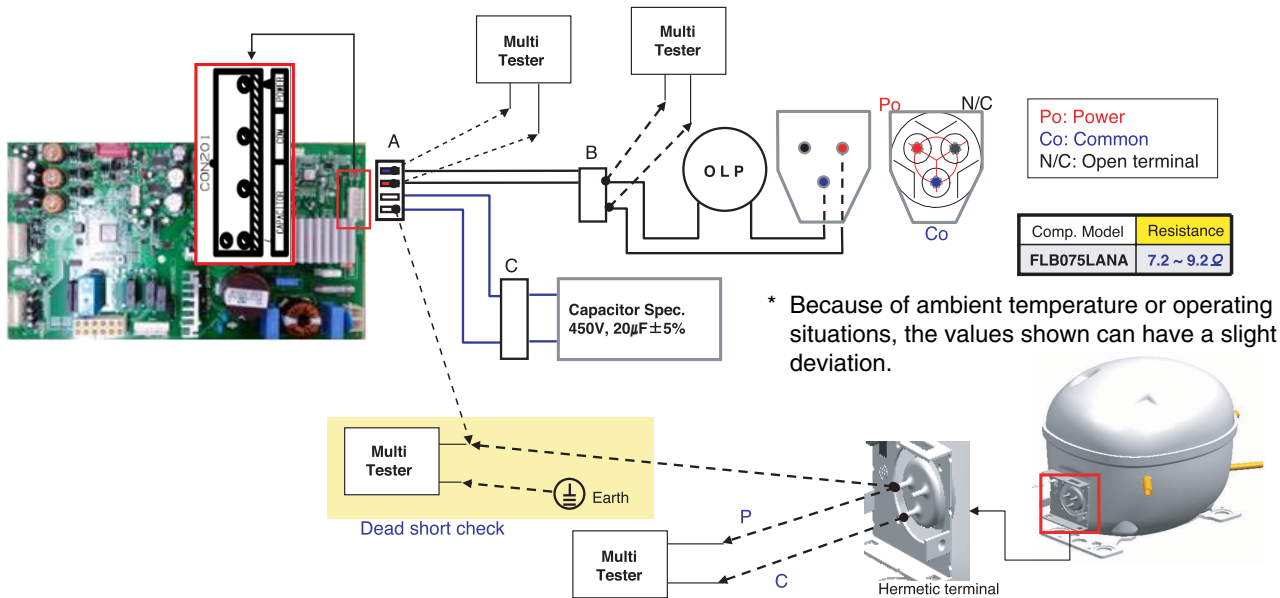

11-4 Check D

D1. Activate Protection logic

Cycle check with protection logic

- We have to check Condenser fan and Freezer fan before performing Check D
- Locked Piston, Current trip and stroke trip can be activated by other problems than the driver or compressor.

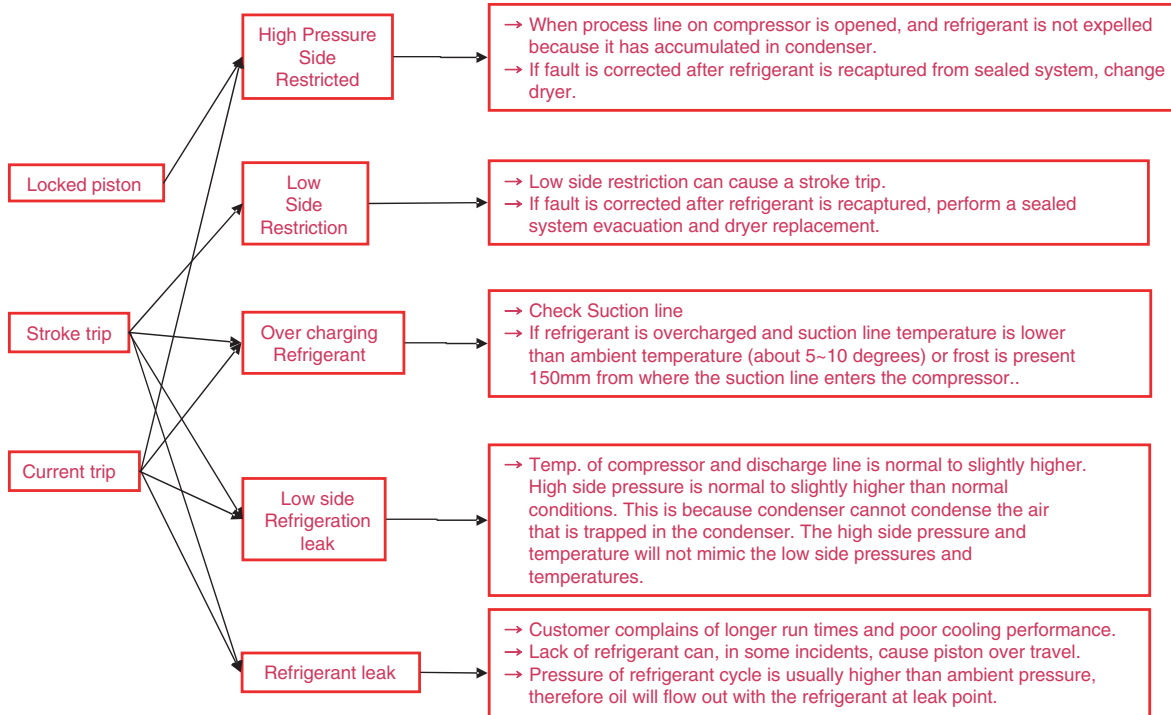

D2. sealed system diagnosis

- Check as follows;

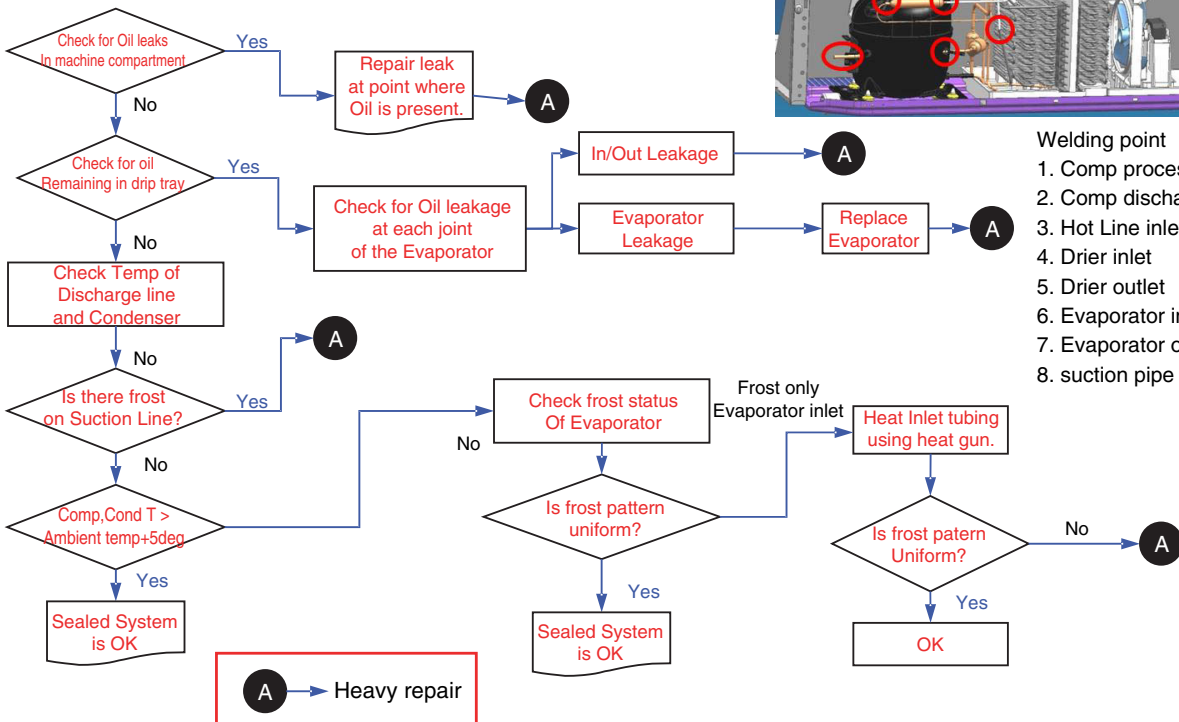

Compressor Troubleshooting

⚠ WARNING HIGH VOLTAGE

Step 1) Open PCB cover







Step 2) Check for blinking frequency of LED and PCB



LED Lamp

When compressor is normal, it does not blink
: Refer to the next page to find out what actions to take according to how many times LED blink

No	LED operating condition	Cause	Service guideline
1	<p>LED two - time repetiton (Stroke Trip)</p>  <p>..on - on - off - on - on - off - on - on - off ..repeating</p>	PCB Parts defect or Compress or Connector miss connecting (Piston over run)	<ol style="list-style-type: none"> 1. Please check, Whether connector of compressor is attached rightly or not. after power off 2. After the first action, You check on normal operation of compressor. 3. If the same symptom arises after the second action, replace PCB
2	<p>LED five - time repetiton (Piston Lock Trip)</p>  <p>..on - on - on - on - on - off - on - on - on - on - on - off .. repeating</p>	Piston constraint	<ol style="list-style-type: none"> 1. After resetting power, check if it is running normal 2. If the same symptom arises after the first action 3. If the same symptom arises after the second action, replace compressor
3	<p>LED six - time repetiton (Current Trip)</p>  <p>..on - on - on - on - on - on - off - on - on - on - on - on - off ..repeating</p>	Circuit over current error Or cycle error	<ol style="list-style-type: none"> 1. After resetting power, check if it is running normal 2. If the same symptom arises after the first action 3. If the same symptom arises after the second action, replace compressor
4	<p>LED seven- time repetiton (IPM Fault Trip)</p>  <p>..on - on - on - on - on - on - on - off - on - on - on - on - on - on - off ..repeating</p>	PCB parts defect (IPM)	<ol style="list-style-type: none"> 1. After resetting power, check if it is running normal 2. If the same symptom arises after the first action, replace PCB

11-5 SERVICE DIAGNOSIS CHART

COMPLAINT	POINTS TO BE CHECKED	REMEDY
No Cooling.	<ul style="list-style-type: none"> Is the power cord unplugged from the outlet? Check if the power switch is set to OFF. Check if the fuse of the power switch is shorted. Measure the voltage of the power outlet. 	<ul style="list-style-type: none"> Plug into the outlet. Set the switch to ON. Replace the fuse. If the voltage is low, correct the wiring.
Cools poorly.	<ul style="list-style-type: none"> Check if the unit is placed too close to the wall. Check if the unit is placed too close to the stove, gas cooker, or in direct sunlight. Is the ambient temperature too high or the room door closed? Check if food put in the refrigerator is hot. Did you open the door of the unit too often or check if the door is sealed properly? Check if the Control is set to Warm position. 	<ul style="list-style-type: none"> Place the unit about 4 inches (10 cm) from the wall. Place the unit away from these heat sources. Lower the ambient temperature. Put in foods after they have cooled down. Don't open the door too often and close it firmly. Set the control to Recommended position.
Food in the Refrigerator is frozen.	<ul style="list-style-type: none"> Is food placed in the cooling air outlet? Check if the control is set to colder position. Is the ambient temperature below 41°F(5°C)? 	<ul style="list-style-type: none"> Place foods in the high-temperature section. (front part) Set the control to Recommended position. Set the control to Warm position.
Condensation or ice forms inside the unit.	<ul style="list-style-type: none"> Is liquid food sealed? Check if food put in the refrigerator is hot. Did you open the door of the unit too often or check if the door is sealed properly? 	<ul style="list-style-type: none"> Seal liquid foods with wrap. Put in foods after they have cooled down. Don't open the door too often and close it firmly.
Condensation forms in the Exterior Case.	<ul style="list-style-type: none"> Check if the ambient temperature and humidity of the surrounding air are high. Is there a gap in the door gasket? 	<ul style="list-style-type: none"> Wipe moisture with a dry cloth. It will disappear in low temperature and humidity. Fill up the gap.
There is abnormal noise.	<ul style="list-style-type: none"> Is the unit positioned in a firm and even place? Are any unnecessary objects placed in the back side of the unit? Check if the Drip Tray is not firmly fixed. Check if the cover of the compressor enclosure in the lower front side is taken out. 	<ul style="list-style-type: none"> Adjust the Leveling Screw, and position the refrigerator in a firm place. Remove the objects. Fix the Drip Tray firmly in the original position. Place the cover in its original position.
Door does not close well.	<ul style="list-style-type: none"> Check if the door gasket is dirty with an item like juice. Is the refrigerator level? Is there too much food in the refrigerator? 	<ul style="list-style-type: none"> Clean the door gasket. Position in a firm place and level the Leveling Screw. Make sure food stored in shelves does not prevent the door from closing.
Ice and foods smell unpleasant.	<ul style="list-style-type: none"> Check if the inside of the unit is dirty. Are foods with a strong odor unwrapped? The unit smells of plastic. 	<ul style="list-style-type: none"> Clean the inside of the unit. Wrap foods that have a strong odor. New products smell of plastic, but this will go away after 1-2 weeks.

●Other possible problems:

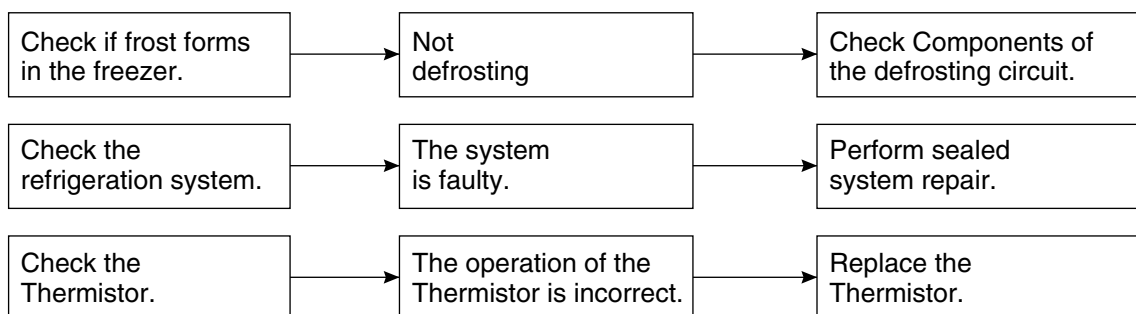

11-6 REFRIGERATION CYCLE

▼ Troubleshooting Chart

CAUSE		STATE OF THE UNIT	STATE OF THE EVAPORATOR	TEMPERATURE OF THE COMPRESSOR	REMARKS
LEAKAGE	PARTIAL LEAKAGE	Freezer compartment and Refrigerator don't cool normally.	Low flowing sound of Refrigerant is heard and frost forms in inlet only.	A little higher than ambient temperature.	<ul style="list-style-type: none"> Refrigerant level is low due to a leak. Normal cooling is possible by restoring the normal amount of refrigerant and repairing the leak.
	COMPLETE LEAKAGE	Freezer compartment and Refrigerator don't cool normally.	Flowing sound of refrigerant is not heard and frost isn't formed.	Equal to ambient temperature.	<ul style="list-style-type: none"> No discharging of Refrigerant. Normal cooling is possible by restoring the normal amount of refrigerant and repairing the leak.
CLOGGED BY DUST	PARTIAL CLOG	Freezer compartment and Refrigerator don't cool normally.	Flowing sound of refrigerant is heard and frost forms in inlet only.	A little higher than ambient temperature.	<ul style="list-style-type: none"> Normal discharging of the refrigerant. The capillary tube is faulty.
	WHOLE CLOG	Freezer compartment and Refrigerator don't cool.	Flowing sound of refrigerant is not heard and frost isn't formed.	Equal to ambient temperature.	<ul style="list-style-type: none"> Normal discharging of the Refrigerant.
MOISTURE CLOG		Cooling operation stops periodically.	Flowing sound of refrigerant is not heard and frost melts.	Lower than ambient temperature.	<ul style="list-style-type: none"> Cooling operation restarts when heating the inlet of the capillary tube.
DEFECTIVE COMPRESSION	COMP-RESSION	Freezer and Refrigerator don't cool.	Low flowing sound of refrigerant is heard and frost forms in inlet only.	A little higher than ambient temperature.	<ul style="list-style-type: none"> Low pressure at high side of compressor due to low refrigerant level.
	NO COMP-RESSION	No compressing operation.	Flowing sound of refrigerant is not heard and there is no frost.	Equal to ambient temperature.	<ul style="list-style-type: none"> No pressure in the high pressure part of the compressor.

11-6-1 Cleaning

There is no need for routine condenser cleaning in normal Home operating environments. If the environment is particularly greasy or dusty, or there is significant pet traffic in the home, the condenser should be cleaned every 2 to 3 months to ensure maximum efficiency.

If you need to clean the condenser:

- Remove the mechanical cover.
- Use a vacuum cleaner with a soft brush to clean the grille, the open areas behind the grille and the front surface area of the condenser.
- Replace the mechanical cover.

11-6-2 SEALED SYSTEM DIAGNOSIS

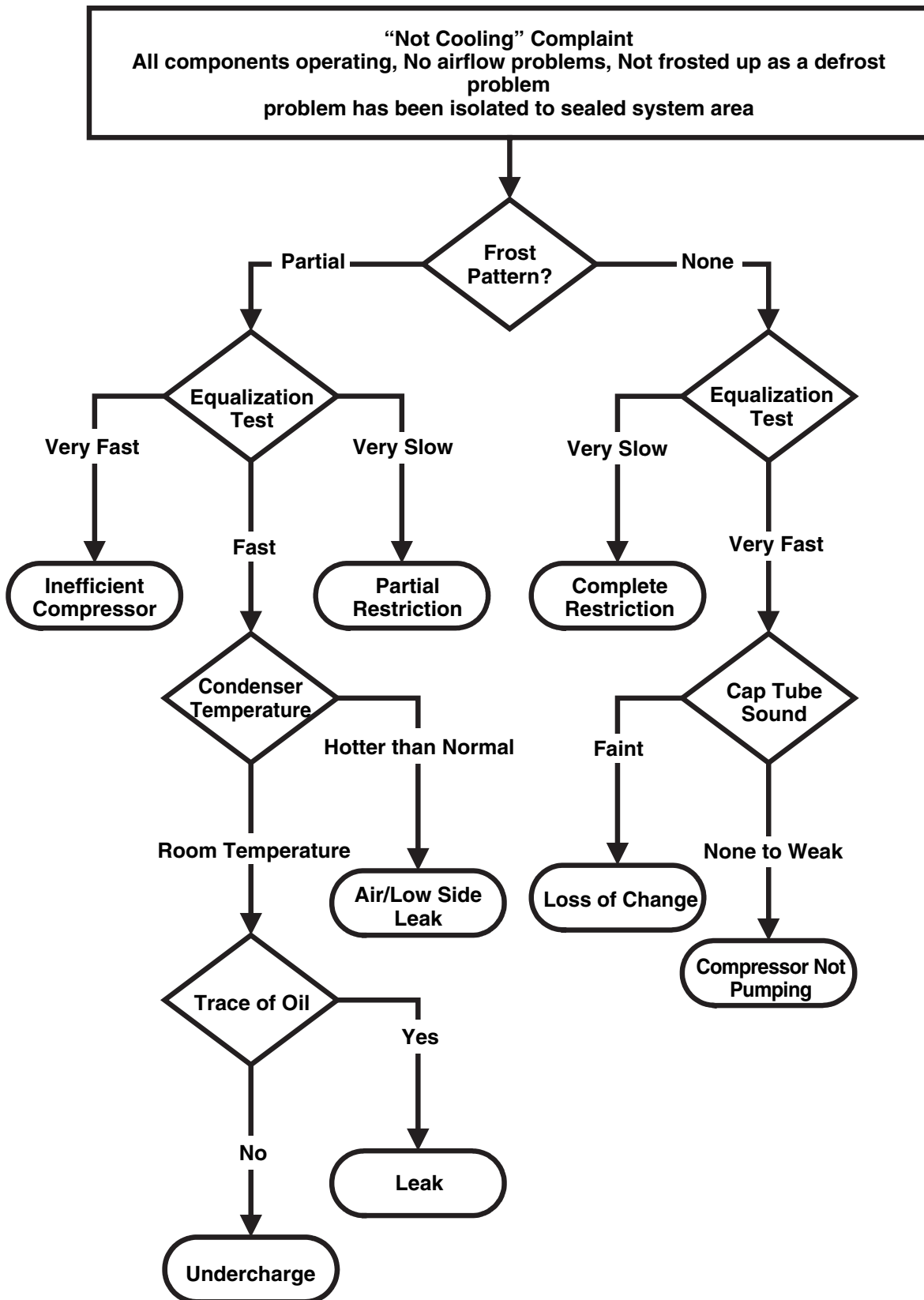

(The equalization test is trying to restart a compressor using a start kit after it has been operating.)

12. ICEMAKER OPERATING METHOD AND TROUBLE SHOOTING

12-1 Icemaker's Basic Operating Method

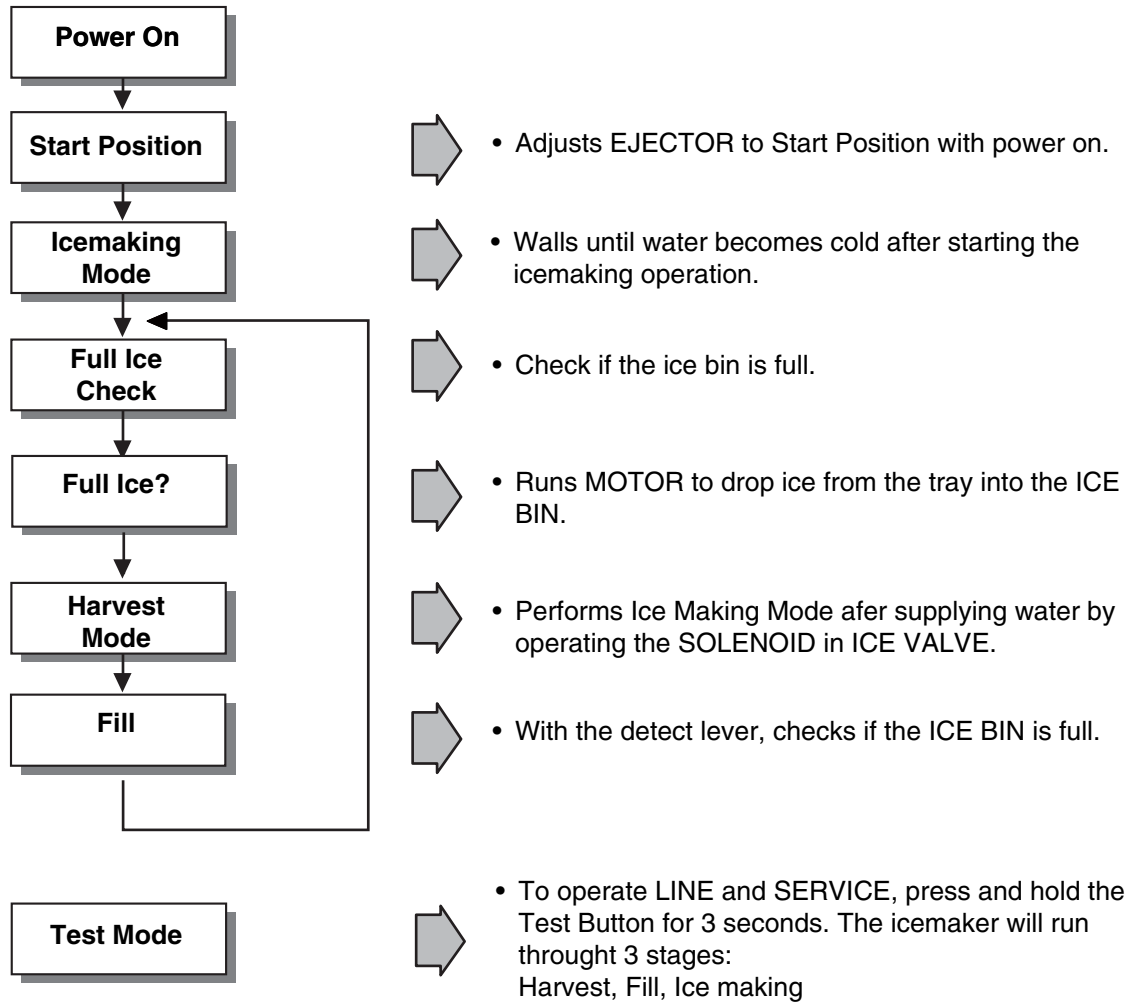

※ While ICE OFF indicator is on, icemaker stops making ice. But you can disense the ices until the ices run out from the ice stoare.

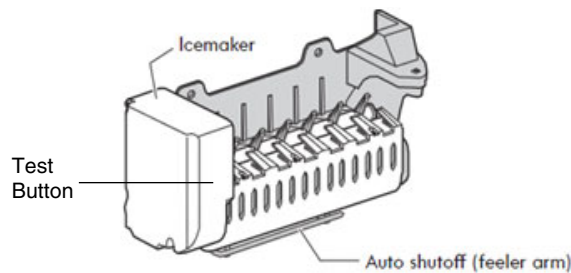

12-2 Trouble Shooting Ice & Water system Issues

12-3-1 Icemaker not making ice or not making enough ice (Environmental Diagnosis)

► Icemaker can't make ices itself. Basically, water, temperature and time are needed.

- Water : If no Water, then no Ice.
- Temperature : The compartment, where the icemaker is located, has to be at least 1°F so that icemaker dumps ices to the bin.
- Time : At least 35 minutes must be passed to make one series of ices after water comes into icemaker.

※ **Test Mode should not be carried out before checking below.**

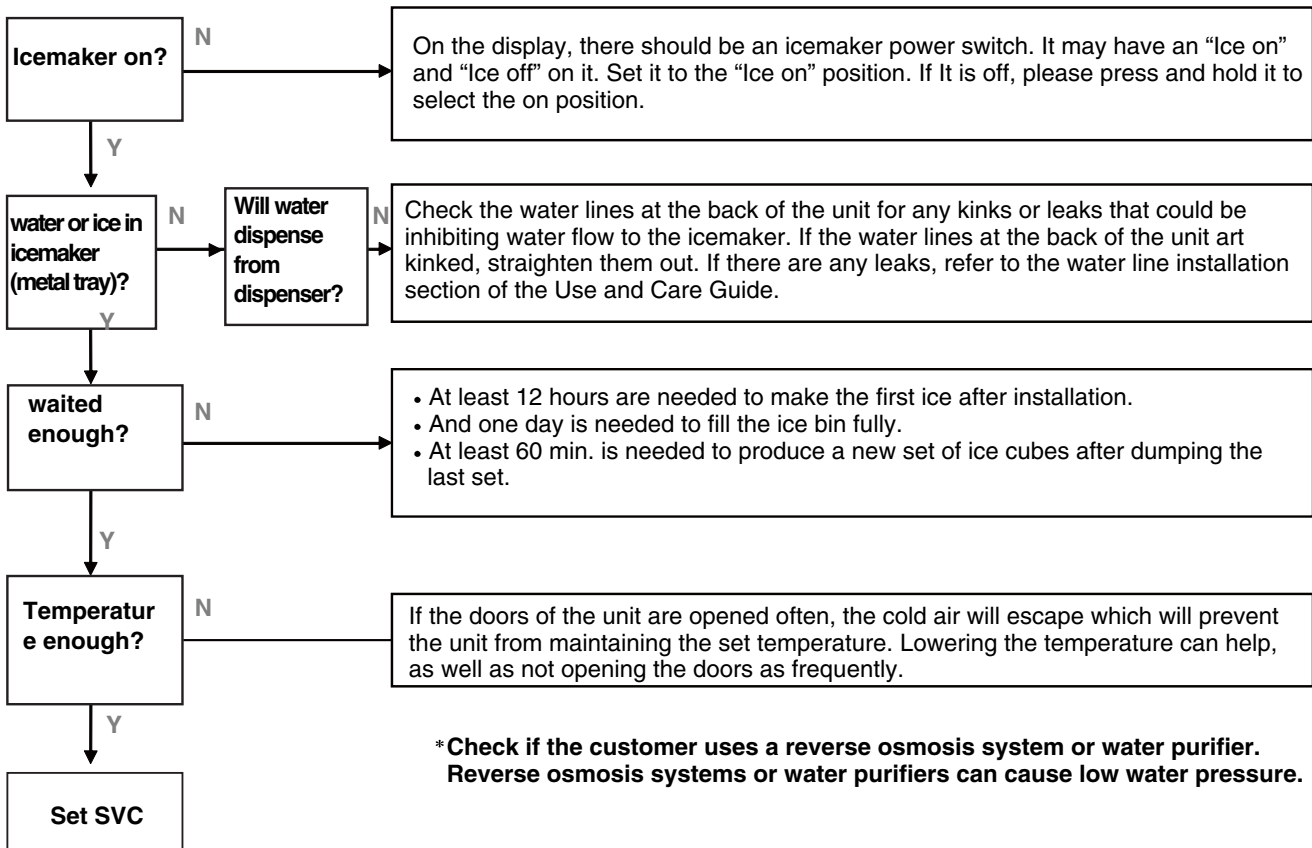

13. ICE MAKER (Freezer Room) OPERATING METHOD AND TROUBLE SHOOTING

13-1 Working Principles

14-1-1 Ice Maker Working Principles

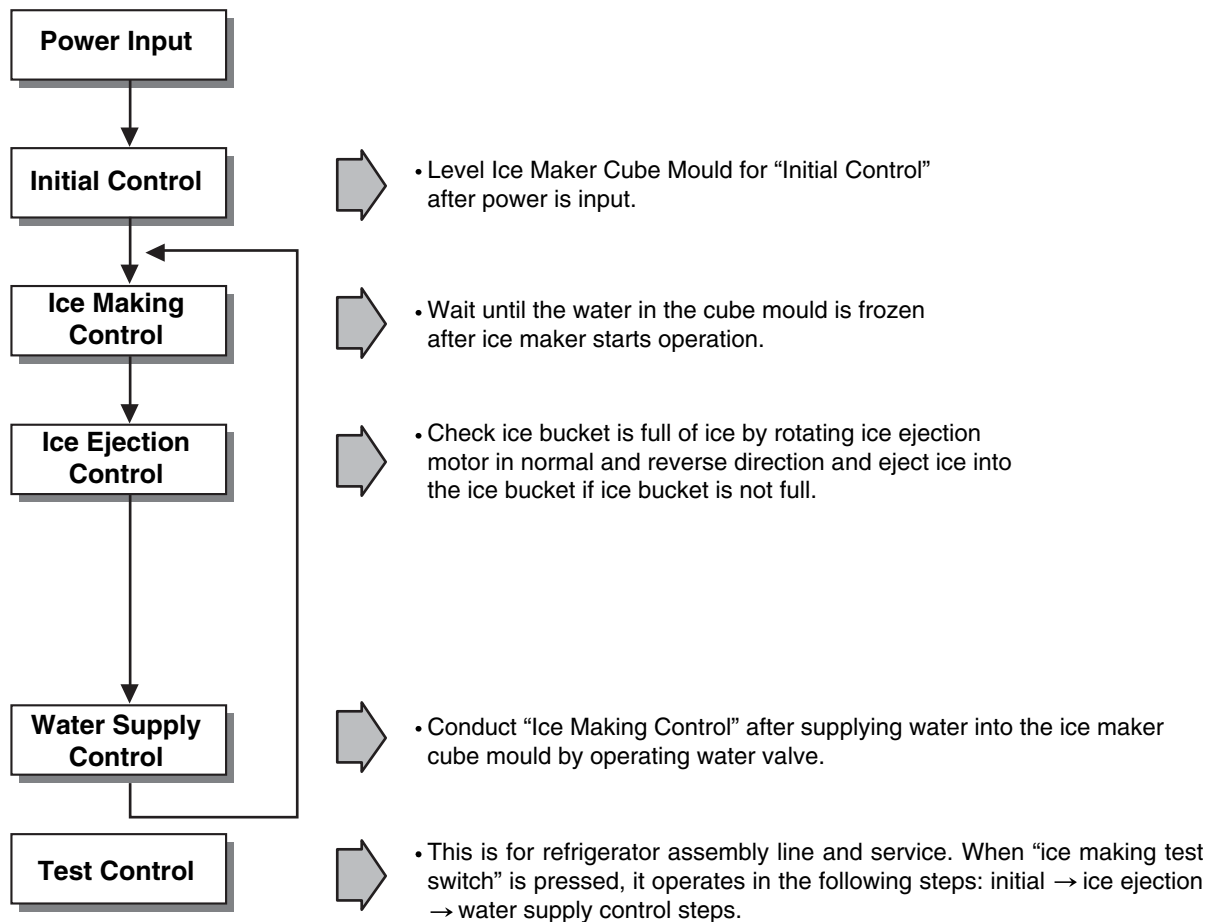

1. Turning the Icemaker stop switch off (O) stops the Icemaking function.
2. Setting the Icemaker switch to OFF and then turning it back on will reset the Icemaker control.

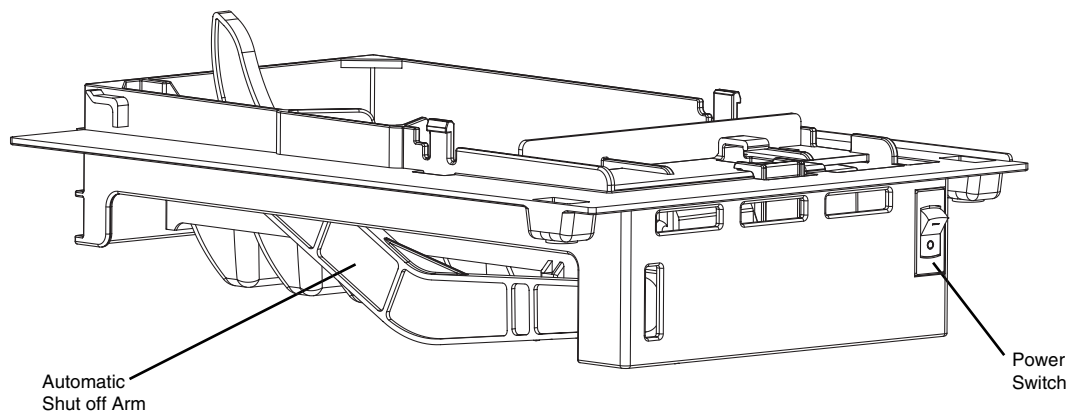

13-2 Function of Ice Maker

13-2-1 Initial Control Function

1. When power is initially applied or reapplied after power cut, it detects level of ice maker cube mould after completion of MICOM initialization. The detecting lever moves up and down.
2. The level of ice maker cube mould is judged by output signal, high and low signal, of Hall IC. Make the cube mould to be horizontal by rotating ice ejection motor in normal or reverse direction.
3. If there is no change in signals one minute after the geared motor starts to operate, it stops icemaker operation and check the signal every hour. It resets initialization of icemaker when it becomes normal.
4. It judges that the initial control is completed when it judges the ice maker cube mould is horizontal.
5. Ice ejection conducts for 1 cycle irrespect of ice in the ice bucket when power is initially applied.

13-2-2 Water Supply Control Function

1. This is to supply water into the ice maker cube mould by operating water valve in the machine room when ice ejection control is completed and ice maker mould is even.
2. The quantity of water supplied is determined by DIP switch and time.

<Water Supply Quantity Table>

No	DIP SWITCH SETTING		WATER SUPPLY TIME	REMARKS
	S1	S2		
1	OFF	OFF	9 SEC	* The quantity of water supplied depends on DIP switch setting conditions and water pressure as it is a direct tap water connection type. (the water supplied is generally 60 cc to 100 cc)
2	ON	OFF	8 SEC	
3	OFF	ON	10 SEC	
4	ON	ON	11 SEC	

3. If water supply quantity setting is changed while power is on, water supplies for the amended time. If DIP switch is changed during water supply, water shall be supplied for the previous setting time. But it will supply for the amended time from the next supply.
4. When water supply signal is applied to water and ice valves at the same time during water supply, water shall be supplied to water valve. If water supply signal is applied to ice valve during water supply, water shall be supplied to both water and ice valves.

13-2-3 Ice Making Control Function

1. Ice making control is carried out from the completion of water supply to the completion of ice making in the cube mould. Ice making sensor detects the temperature of cube mould and completes ice making. (ice making sensor is fixed below ice maker cube mould)
2. Ice making control starts after completion of water supply control or initial control.
3. At first, It is judged that ice making is completed when ice making sensor temperature reaches at -8°C after 70 minutes when water is supplied to ice maker cube mould.
4. Finally, It is judged that ice making is completed when ice maker sensor temperature reaches below -8 °C after 10 minutes in condition 3.

13-2-4 Ice Ejection Control Function

1. This is to eject ice from ice maker cube mould after ice making is completed.
2. If Hall IC signal is on within 3.6 seconds after ice ejection motor rotates in normal direction, it does not proceed ice ejection but waits. If the ice bucket is full, ice ejection motor rotates in normal direction in every hour to check the condition of ice bucket. If the ice bucket is not full, the water supply control starts after completion of ice ejection control. If the ice bucket is full, ice ejection motor rotates in reverse direction and stops under ice making or waiting conditions.
3. If ice bucket is not full, ice ejection starts. The cube mould tilts to the maximum and ice is separated from the mould and ice checking lever raises.
4. Ice ejection motor stops for 1 second if Hall IC signal changes from OFF (low) to ON (high) after 3.6 seconds when ice ejection motor rotates in normal direction. If there is no change in Hall IC signals within 1 minute after ice ejection motor operates, ice ejection motor stops as ice ejection motor or hall IC is out of order.
5. If ice ejection motor or Hall IC is abnormal, ice ejection motor rotates in normal direction to exercise initial operation. It resets the ice maker if ice ejection motor or Hall IC is normal.
6. The mould stops for 1 second at maximum tilted conditions.
7. The mould returns to horizontal conditions as ice ejection motor rotates in reverse direction.
8. When the mould becomes horizontal, the cycle starts to repeat:
Water Supply → Ice Making → Ice Ejection → Mould Returns to Horizontal
9. When freezer door is open, ice ejection don't operating, and after 1minute of Freezer door closing, ejection control function is operated.

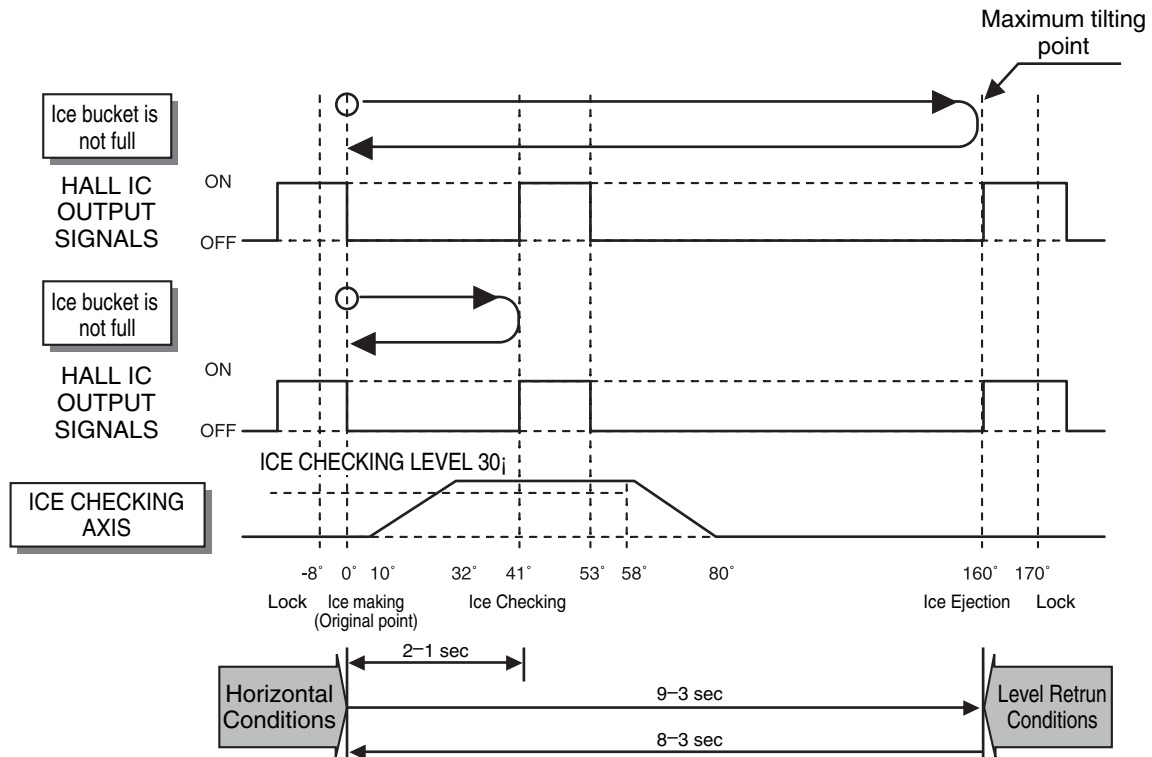

<Timing Chart During Ice Ejection>

13-2-5 Test Function

1. It is to force the operation during operation test, service, and cleaning. The test switch is mounted under the automatic ice maker. The test function starts when the test switch is pressed for more than 0.5 second.
2. Test button does not work during ice ejection and water supply. It works when it is in the horizontal conditions. If mould is full of ice during test function operation, ice ejection control and water supply control do not work.
3. When test switch is pressed for more than 0.5 second in the horizontal conditions, ice ejection starts irrespect of the mould conditions. Water shall be splashed if test switch is pressed before the water in the mould freezes. Water shall be supplied while the mould returns to the horizontal conditions after ice ejection. Therefore the problems of ice ejection, returning to the horizontal conditions, and water supply can be checked by test switch. When test function performs normally, buzzer sounds and water supply shall carry out. Check it for repair if buzzer does not sound.
4. When water supply is completed, the cycle operates normally as follows: Ice making → Ice ejection → Returning to horizontal conditions → Water supply
5. Remove ice from the ice maker cube mould and press test switch when ice maker cube mould is full of ice as ice ejection and water supply control do not work when cube mould is full of ice.

14. DESCRIPTION OF FUNCTION & CIRCUIT OF MICOM

14-1 FUNCTION

14-1-1 Function

- When the appliance is plugged in, it is set to 37° F for Refrigerator and 0°F for freezer.
You can adjust the Refrigerator and the Freezer control temperature by pressing the ADJUST button.
- When the power is initially applied or restored after a power failure, it is set to Control temperature Previously.
- If you do not press any button after turning on the power, only CRUSH or CUBE Label that has been selected will be turned on and all other LEDs on the display Panel will be turned off within 60 seconds. (Power Save Mode)
- If you press a button, only CRUSH, CUBE label and Lock icon that has been selected will be turned on and all other LEDs on the display Panel will be turned off within 20 seconds. (Power Save Mode)

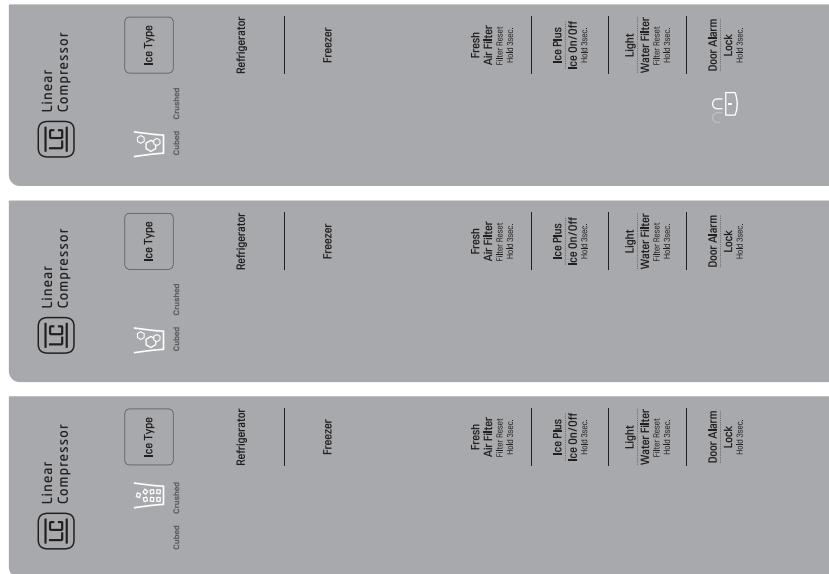

14-1-2 How to Toggle the Display between °F & °C

- The initial setting is °F and the display temperature mode can be changed from °F to °C or °C to °F by pressing and holding the FRZ TEMP and the REF TEMP keys at the same time for over 5 seconds.

14-1-3 Lock function (dispenser and display button lock)

- When the refrigerator is first turned on, the buttons are not locked. "LOCK" is deactivated with "Unlock Icon" on.
- To lock the display, the dispenser, and the control panel, press and hold the LOCK button for 3 seconds. "LOCK" is activated with "Lock Icon" on.
- The LOCK button is the only control feature that remains active in the locked state. The buzzer sound, other control buttons, and the dispenser are deactivated.
- To release from the locked state, press and hold the LOCK button again for 3 seconds.
- If you don't hold the Alarm/Lock button more than 3 seconds, Alarm function will be changed and alarm for opened door will be on/off same as alarm icon indicating.



Ex) In selecting "LOCK"

Ex) In selecting "LOCK" again

14-1-4 Filter condition display function

1. There is a replacement indicator light for the filter cartridge on the dispenser.
2. Water filter needs replacement once six months or of using water filter.
3. When the Water Filter Icon blinks, you must exchange the filter.
4. After replacing the filter, press and hold the Light/Filter button for more than 3 seconds.
After then water Filter icon turn off with reset status.

Classification

In initial Power On / Filter RESET	Blinking

Filter Status Display

14-1-5 Air Filter condition display function

1. There is a replacement indicator light for the Air Filter cartridge.
2. Air filter needs replacement once every 6 months.
3. When the charger Icon blinks, you must exchange the filter.
4. After replacing the filter, press and hold Air filter button for more than 3 seconds.
After then Air filter icon turn off with reset status.

Classification

In initial Power On / Filter RESET	Blinking

Filter Status Display

14-1-6 Air Filter selection

Please select this function for Air Filter.

1. When you press the Air Filter Button, the POWER will be turned on again.
2. Air Filter POWER function automatically turns off after a fixed time passes.



14-1-7 Ice Plus selection

1. Please select ice plus function for quick freezing.
2. When you press the ice plus button, the ice plus icon will be turned on again.
3. Ice plus function automatically turns off after a fixed time passes.



14-1-8 Dispenser use selection

You can select water or ice by separated pad switch.

1. When you press ice type button, ice type will be changed. (Crush or Cube)
2. Hold your cup in the dispenser for a few seconds after dispensing ice or water to allow the last pieces of ice drops of water to fall into the cup.
3. When after initially establishing the water comes out, the water tank inside fills and until at the time of quality the hour is caught.



WATER PAD
ICE PAD

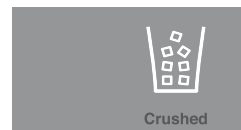

14-1-9 CONTROL OF FREEZER FAN MOTOR

1. Freezer fan motor has high and standar speed.
2. When refrigerator is overloaded, fan motor runs in high speed as powered-up Standard speeds is used for general purposes.
3. To improve cooling speed, the RPM of freezer fan motor changes from normal speed to high.

14-1-10 Cooling Fan Motor

1. The cooling fan is switched ON and OFF in conjunction with the compressor.
2. The Failure sensing method is the same as in the fan motor of the freezing fan motor(refer to failure diagnosis function table for failure display).

14-1-11 Ice Compartment Fan

1. The Icing Fan is controlled by the the sensor on the top of the ice compartment.
2. The Failure sensing method is the same as in the fan motor of the freezer (refer to failure diagnosis function table for failure display)

14-1-12 Refrigeration room Fan Motor

1. The refrigeration room fan is switched ON and OFF in conjunction with the refrigeration room temperature.
2. The Failure sensing method is the same as in the fan motor of the freezing fan motor (refer to failure diagnosis function table for failure display).

14-1-13 Ice PLUS

1. The purpose of this function is to intensify the cooling speed of freezer and to increase the amount of ice.
2. Whenever selection switch is pressed, selection/release, the Icon will turn ON or OFF.
3. If there is a power outage and the refrigerator is powered on again, Ice PLUS will be canceled.
4. To activate this function, press the Ice PLUS key and the Icon will turn ON. This function will remain activated for 24 hrs.
 - (1) control temperature of freezer room is to set -2 ° F notch temperture.
 - (2) If ice bin is full of ice, no change logic of ice compartment fan.
 - (3) If funcion is activitied and de-ice status to be, ice compartment fan is operated by force.
 - Upper RT 18 ° C, Standard RPM
 - Below RT 18 ° C, operate low speed RPM

14-1-14 How to set the display mode and cancel it

1. With the refrigerator door open, keep pressing the Refrigerator Temp Button and ICE PLUS Button more than 5 seconds, then it goes to the display mode with Special Beep Sound With Special Beep Sound.
2. Perform the same way again to cancel the display mode.
3. All Freezing unit will be turned off at display mode (Exceptions : Lamp, Display)

14-1-15 Defrosting (removing frost)

1. Defrosting starts each time the COMPRESSOR running time Between 7~50 hours.
2. Defrosting stops if the sensor temperature reaches 41°F(5°C) or more. If the sensor doesn't reach 41°F(5°C) in 1 hours, the defrost mode is malfunctioning. (Refer to the defect diagnosis function)
3. Defrosting won't function if its sensor is defective (wires are cut or short circuited)

14-1-16 Defect Diagnosis Function

1. Automatic diagnosis makes servicing the refrigerator easy.
2. When a defect occurs, the buttons will not operate.
3. When the defect CODE removes the sign, it returns to normal operation (RESET).
4. The defect CODE shows on the Refrigerator and Freezer Display.



- * Display check function: If simultaneously pressing Ice Plus button and freezing temperature adjustment button for a second, display LCD graphics on. If releasing the button, the LCD graphic displays the previous status.
You can check the error code Within 3-hour Period from initial error

14-1-17 Auto pantry

1. The temperature control will automatically start upon the selected Auto Pantry temperature control.
2. You can adjust the Pantry control with three different temperature ranges by pressing the Temp.Selector button.

15. EXPLODED VIEW & REPLACEMENT PARTS LIST

CASE PARTS

CAUTION : Use the part number to order part, not the position number.

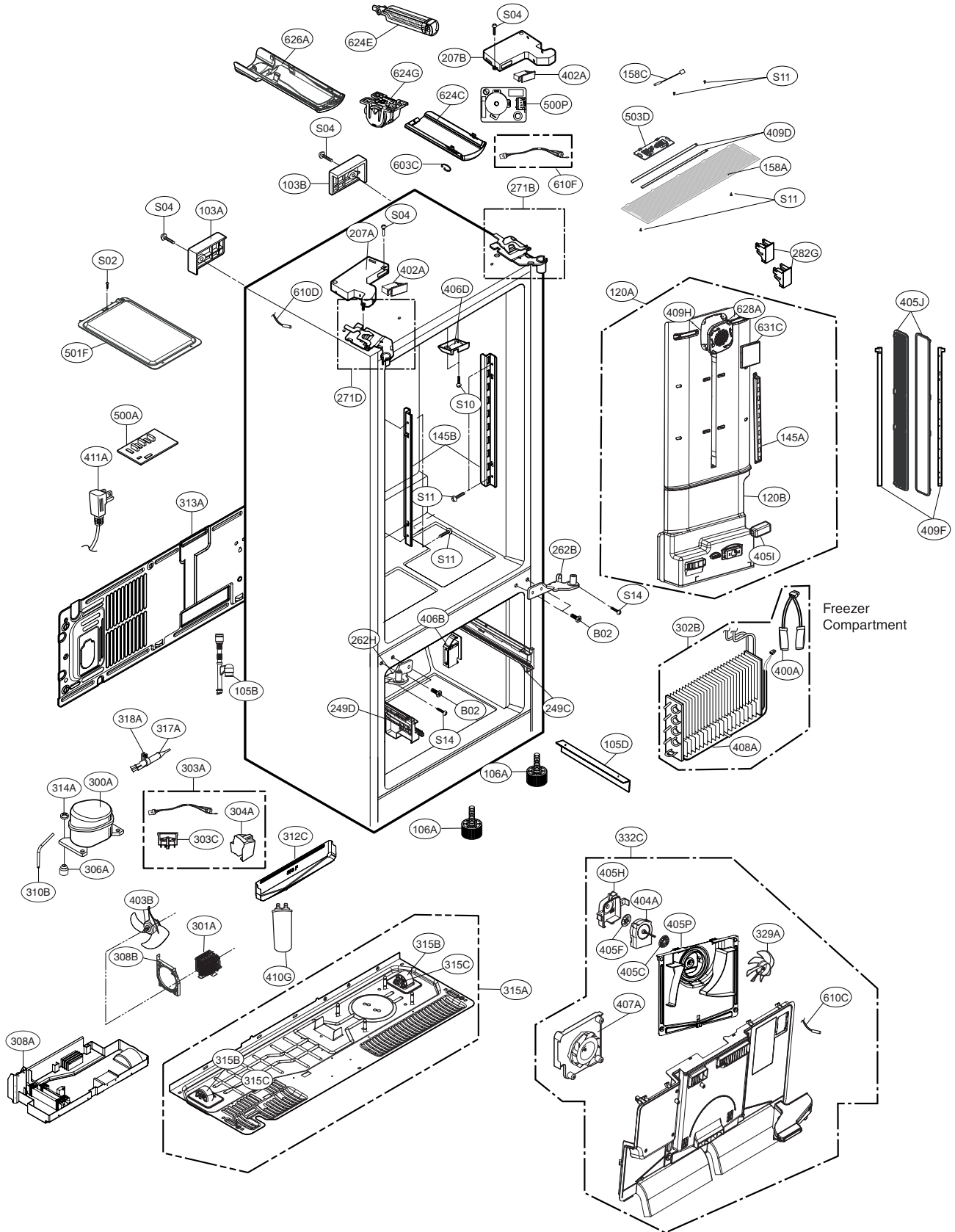

FREEZER PARTS

CAUTION: Use the part number to order part, not the position number.

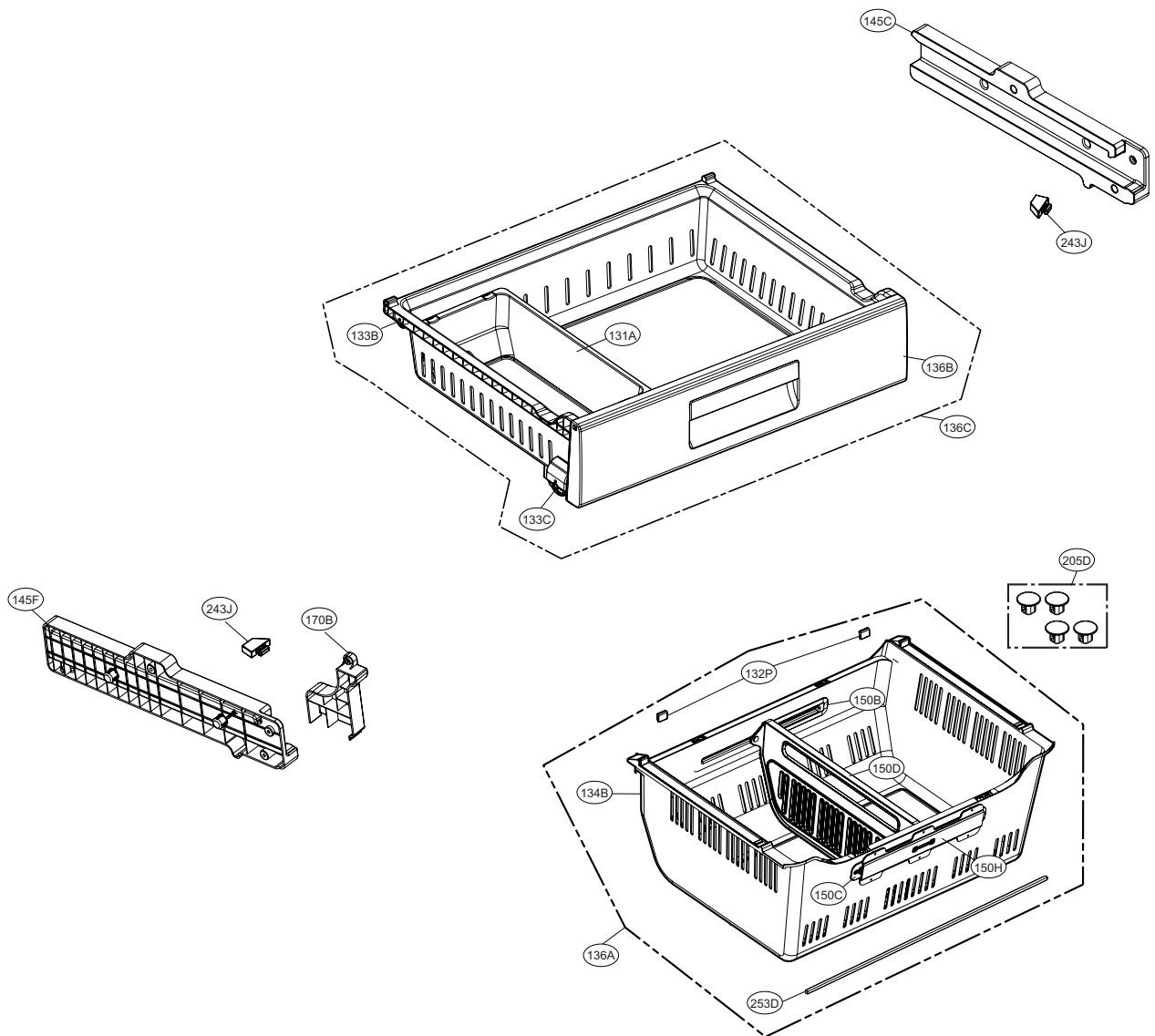

REFRIGERATOR PARTS

CAUTION: Use the part number to order part, not the position number.

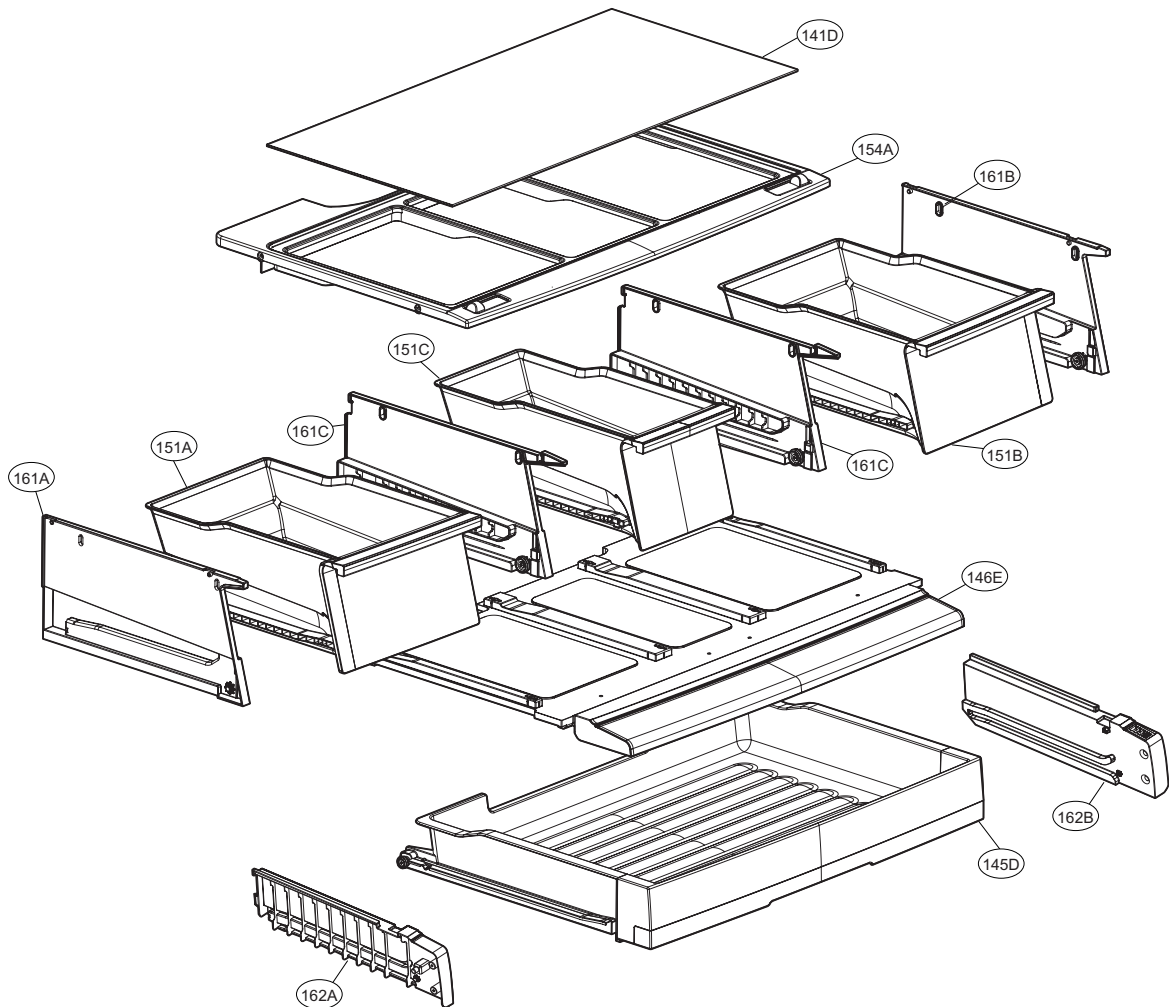
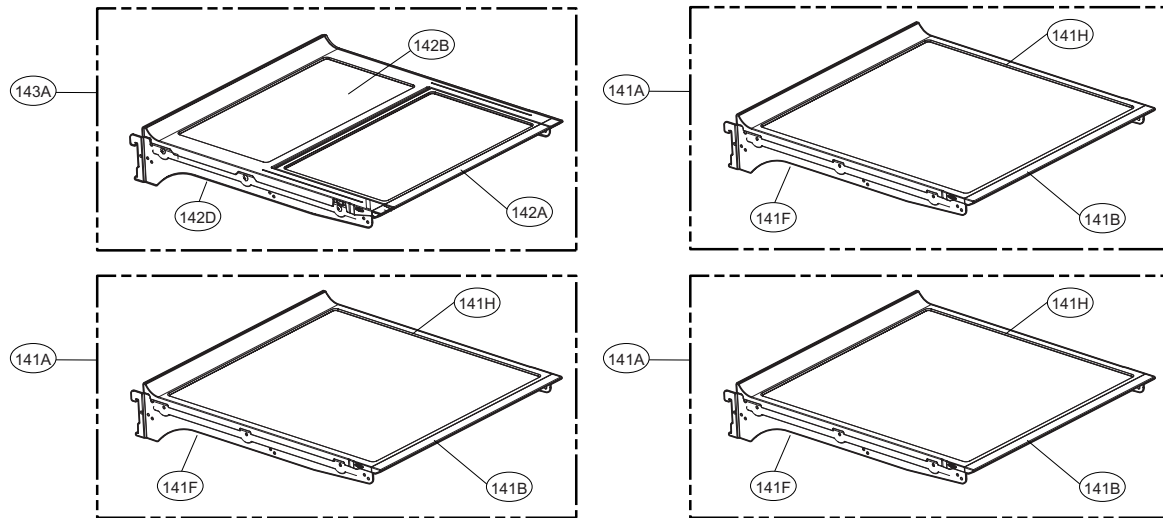

DOOR PARTS

CAUTION: Use the part number to order part, not the position number.

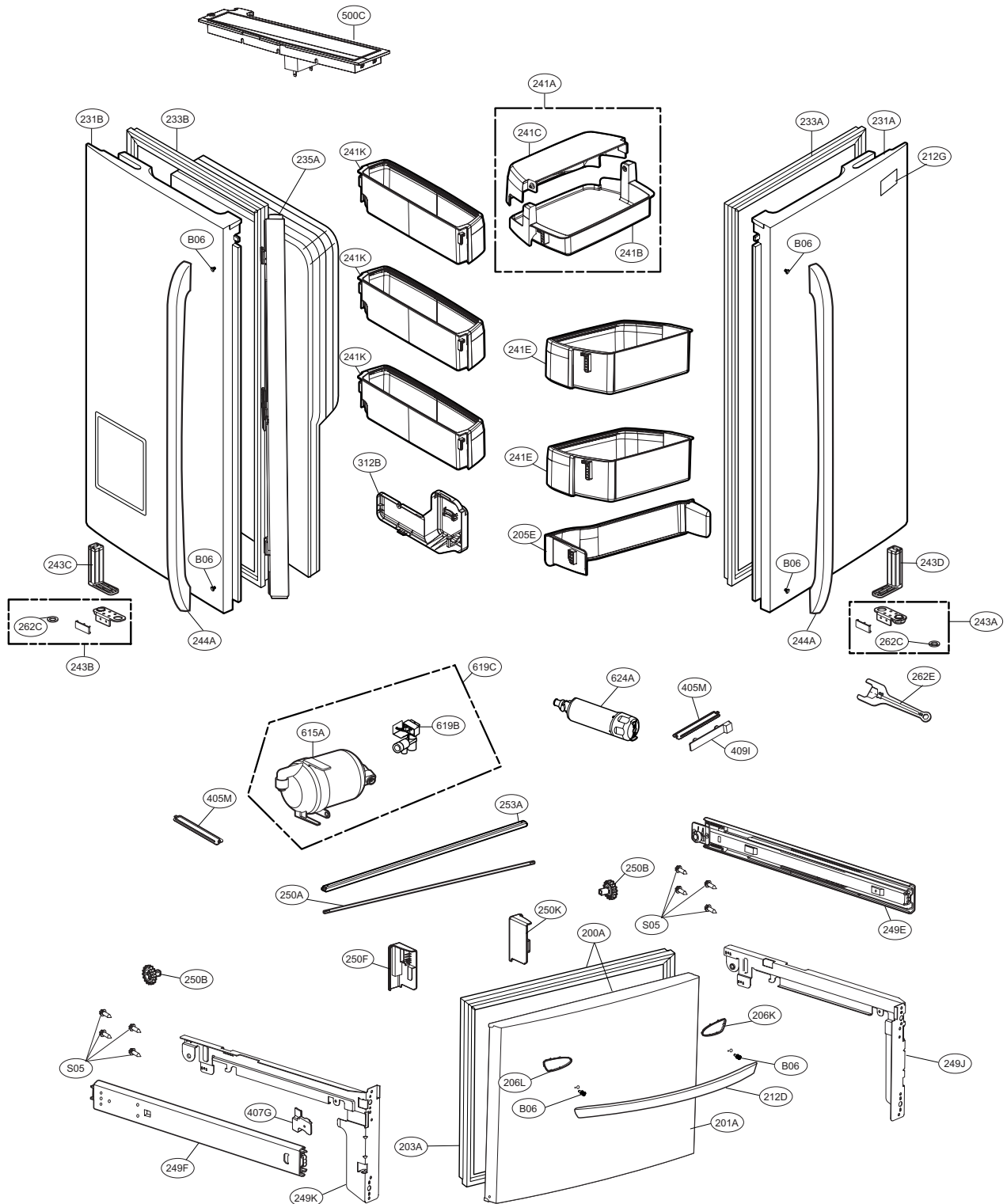

DISPENSER PARTS

CAUTION: Use the part number to order part, not the position number.

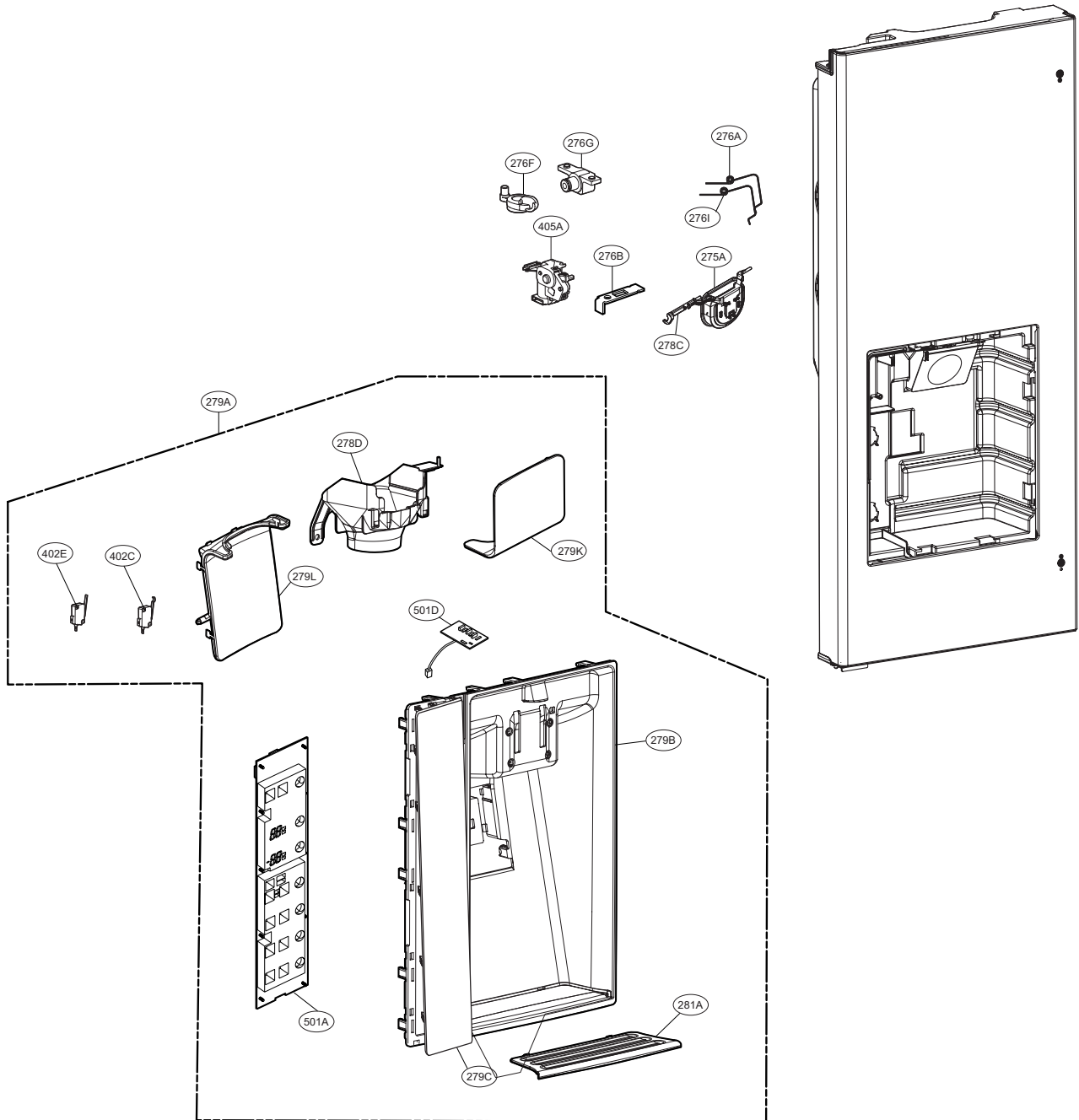

VALVE & WATER TUBE PARTS

CAUTION: Use the part number to order part, not the position number.

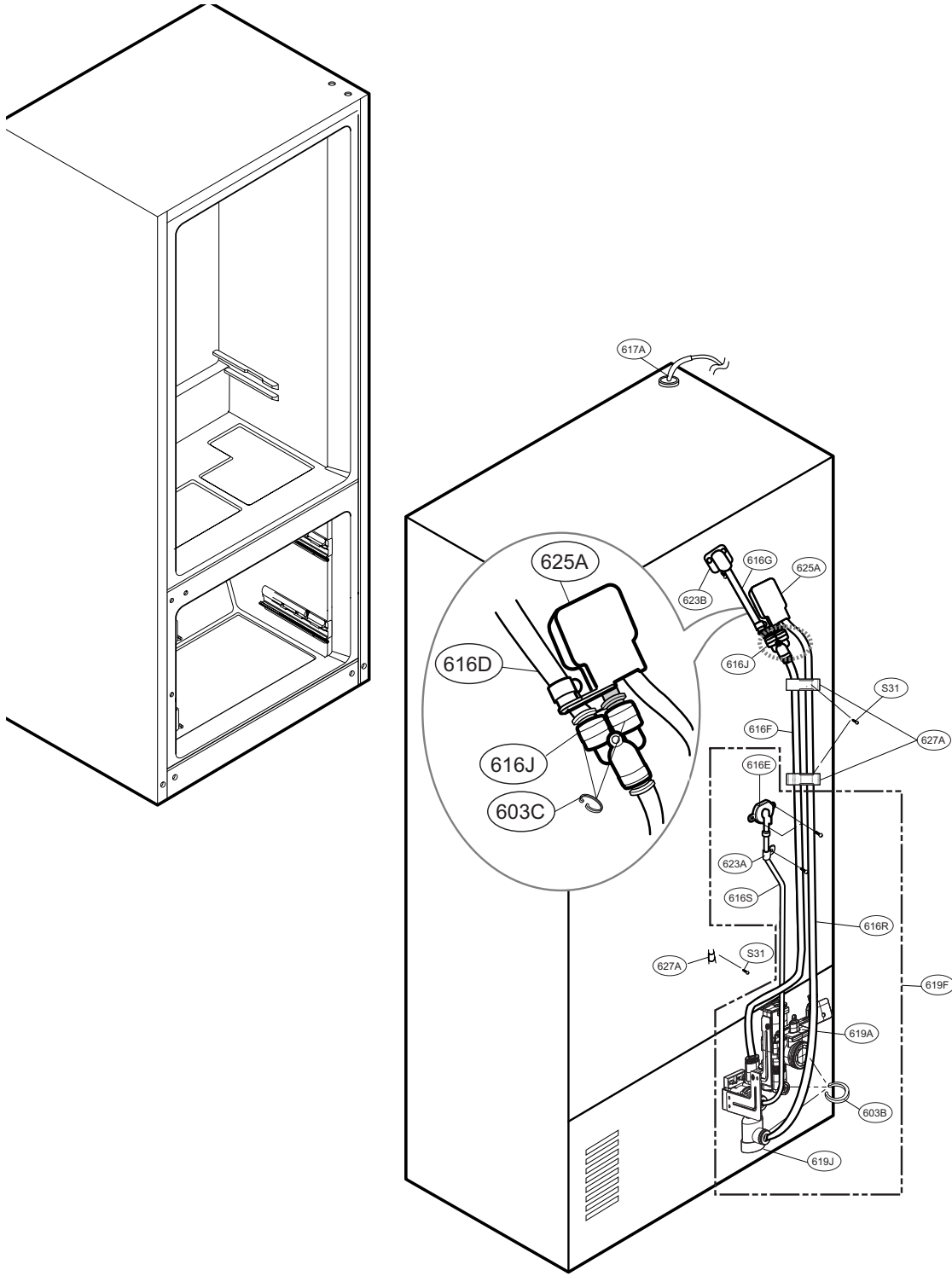

ICE MAKER & ICE BIN PARTS

CAUTION: Use the part number to order part, not the position number.

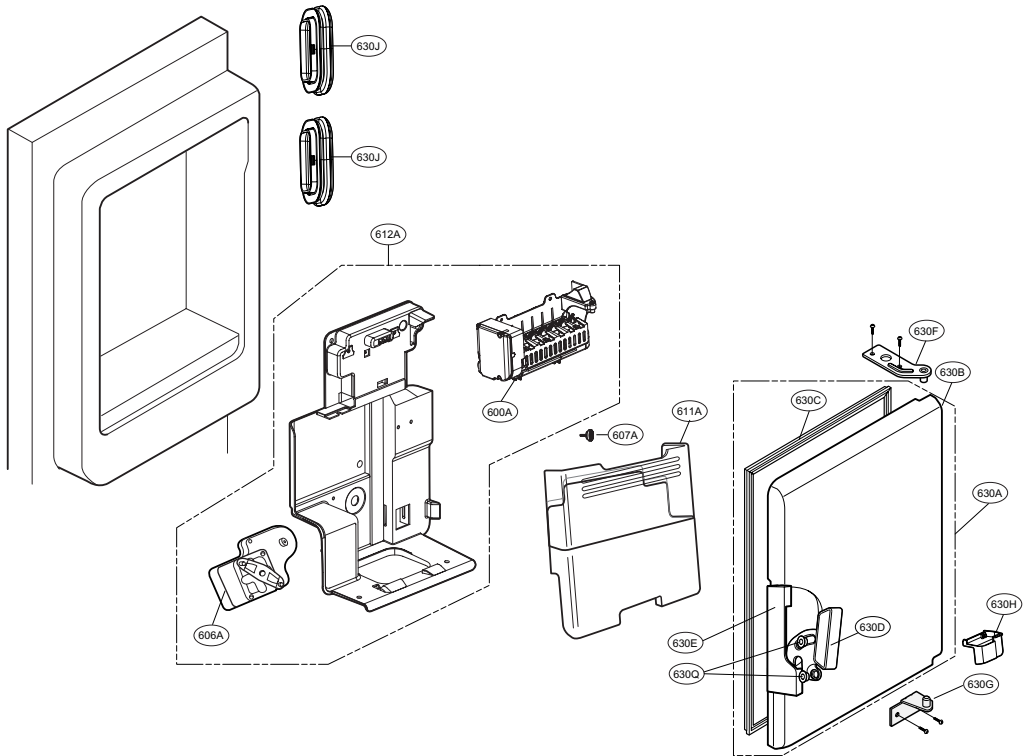

Freezer Room

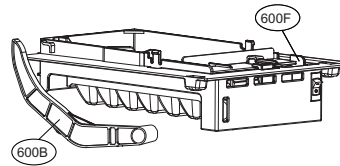
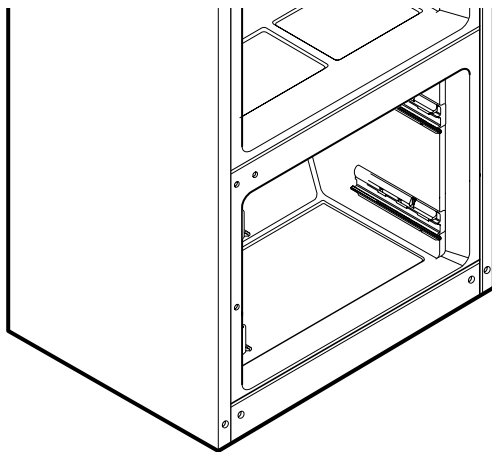



P/No. MFL68488612

JUL., 2014 Printed in Korea